

Industrial Products Source

Vol 22

Issue 4

Thane

April 2025

Pages 60

Price ₹30/-

Visit: www.ips.co.in
to view our e-magazine

Focus:
Pumps & Valves, Pneumatics & Hydraulics,
Petrochemicals, Process Plant & Machinery

Products Index
Page 54

Leading Manufacturer of
Materials Handling
Equipment

CRANE KITS & COMPONENTS



WIRE ROPE HOISTS
Up to 50 Ton



ELECTRIC CHAIN HOISTS
Up to 3 Ton



NEW GENERATION HOISTS
Monorail up to 25 Ton
Double Girder up to 50 Ton



DOWN SHOP LEAD (DSL)



PENDENT PUSH BUTTON



SOCKETED PANELS



CHAIN PULLEY BLOCK
Up to 20 Ton



CABLE DRAG CHAIN



G. G. WHEEL



FASTOON SYSTEM - C RAIL



SHROUDED DSL SYSTEM



WHEEL BLOCK
DRIVE SIDE



WHEEL BLOCK
IDLER



END CARRIAGE



Corporate Office & Plant 1: Plot 5,6,7 Devraj Industrial Park, Piplaj-Pirana Road, Piplaj, Ahmedabad-382405.Gujarat
Plant 2: Plot 613, Phase 4, G.I.D.C., Vatva, Ahmedabad-382445. Gujarat Plant 3: 508, Sompura Industrial Area, Dobaspet, Bengaluru-562111
M: 9875139466 , 93770 39904 | E-mail : salesho@tacklers.in Website : www.tacklers.in

R.K.DUTT

CHANNEL PARTNER FOR
SIEMENS
(Mumbai, Konkan)

Manufacturers of Level Instruments, Reflex
Transparent Boiler Gauges, Sight Glasses
Magnetic Level Indicators, Transmitters, Switches

Over 50 Years of Service
to Process Industry



Other Products:

- Reflex & Tubular Level Gauges
- Magnetic Level Indicators
- Level Switches & Transmitters
- Float & Board Level Indicators
- Manometers & Sight Glasses

R. K. DUTT CONCERNS

AUTHORIZED CHANNEL PARTNER for
SIEMENS Process Instruments.
Manufacturers of LEVEL, PRESSURE, FLOW Indicators.

A-88, Road No. 18, Wagle Estate, Thane 400 604, Maharashtra
Tel.: 022 - 6724 8787 / 2582 2541 • Fax: 022 - 6724 8777
E-mail: marketing@rkdutt.com • Website: www.rkdutt.com

our customize product range make us

**No.1 IN SURFACE
FINISHING SOLUTION**



Spl. Blasting M/c for Roof-Mounted
Pantographs Contact Strips of Electric Rail



Spl. Shot Blasting M/c for Fold-away
Tray of Sheet Molding Compound



Spl. Blasting M/c for Cleaning of
Submersible Pump Casing



Spl. Pressure Blaster Machine
for Roll Etching



PRESERVATION LINE
Inline Blasting, Painting & Baking System



BLAST ROOM & PAINT ROOM SYSTEM
For Paper Industries Machine Manufacturer



**MEC SHOT BLASTING
EQUIPMENTS PVT. LTD.**

H.O. & Works: B-14, Parshvnath Industrial Estate Yojna
Khasra No. 160, Mogra Kalan, Tehsil - Luni
JODHPUR - 342802 (Rajasthan) INDIA

0291-2740609 | E-mail: mail@mecshot.com | Website: www.mecshot.in



EMPIRE CABLES

Connecting Your Life



PRODUCT RANGE

- Power & Control Cables (Aluminium/Copper Conductor/Armoured Unarmoured Cables)
- FR / FRLS PVC Cables (HT & LT Cables)
- House Wiring / Multicore
- Flexible / Industrial Cables
- Hook up Wires
- 3 Core Flat Submersible Cables
- Telecommunication Cables
- Co-axial / Instrumentation / Computer Cables
- Aerial Bunched Cables
- TRS / TRS Braided / Welding Cables
- CCTV / Cat-5 / LAN Cables
- Solar Cables
- Moulded Plugs
- All Kinds of Other Special Cables



Mfg. by :

EMPIRE CABLE INDUSTRIES PVT. LTD.

115, Badli Industrial Area, Phase-2, New Delhi (India)

website : www.empirecables.net

Email : enquiry@empirecables.net

Toll Free No.: 1800-202-7972





Ventura Alloy and Steels Private Limited

We are Importer, Exporter, Stockist, Distributor & Suppliers for Tool & Alloy - Special and Die Steels, Forging Components Spring Steel - Wire Rod, Square & Round Bars Coiled & Disc Springs, Tools Collets, Impact Sockets Etc.



HOT WORK TOOL STEELS



PLASTIC MOULD STEELS



COLD WORK TOOL STEELS



ALLOY STEELS



SPRING STEELS

SUPPLIERS



HOT WORK STEEL

Db6 / AISI L6 / DIN2714
H13 / AISI H13 / DIN 2344
H11 / AISI H11 / DIN 2343
H21 / AISI H21 / DIN 2581
H10 / AISI H10 / DIN 2365
H12 / AISI H12 / DIN 2606

ALLOY STEEL

En24 / AISI 4340 / 40NiCrMo84 / 34CrNiMo6
EN19 / AISI 4140 / 42CrMo4
EN31 / AISI 52100 / 100Cr6
41Cr4 / JIS SCr440H / AFNOR 42C4

COLD WORK STEEL

HCHCR D2 / AISI D2 / DIN2379
HCHCR D3 / AISI D3 / DIN2080
A2 / AISI D2 / DIN 2363
O1 / AISI O1 / DIN 2510
D5 / Cr12MoV / DIN 2601

SPRING STEEL

En47 / 50CrV4 / 51CrV4 / AISI 6150 / SUP10 / DIN 8159
SUP9 / AISI 5155 / DIN 1.7176
SAE 9254 / AISI 9254

PLASTIC MOULD STEEL

P20+Ni / AISI P20+Ni / DIN2738
P20 / AISI P20 / DIN 2311

CARBON STEEL

SAE1080 MS / C45 / EN80 / EN1A / EN1A Pb
C45 / AISI 1042 / JIS S45C
St 52.3 / EN S355JR / JIS SM490A
SAE 1018 / 25CrMo4 / JISCSM420

CASE HARDENING STEEL

20MnCr5 / DIN 1.7147 / SAE 5120 / JIS SMnC420H / 20MCS
SAE8620
17CrNiMo6 / 18CrNiMo6 / DIN 1.6587 / BS En353

Unit No. 1201 & 1202, Ghanshyam Enclave, New Link Road, Near Laljiwada Police Station, Kandivali (West), Mumbai - 400067. Tel. +91 22 35034301 - 307 / 35034311 - 319 Mob: 9819225666 & 8591313565

Stocking / Machining Centre
Gata No. 6, Building No. 163, Indian Corporation, (Mouje Gundavli/Mankoli - Phata) Dapoda, Taluka - Bhiwandi - 421302
Tel : +91 7977097655 | Email: sales@venturasteels.com | Web: www.venturasteels.com

SOVEREIGN SOLUTIONS FOR ALLOY, SPRING AND DIE STEELS

www.venturasteels.com sales@venturasteels.com +91 22 35034301 - 307 / 35034311 - 319 9819225666 & 8591313565

Industrial Products Source

(A Product News Publication)

Vol. 22 No. 4 April 2025

ISSN 0973-1857

Editor & Publisher: Mohanan Naduvalath
Mobile: 098206 70855

Sub Editor: Ramachandran. T
✉: ipseditor@gmail.com

Marketing Manager: V Madanmohan
Mobile: 098208 38998

Layout Artist: Chandrakant G. Kadam

Single copy price: ₹30/-

Annual Subscription: ₹300/-

Registered Address

A/10 Jayshree Laxmi Puja CHS, MES Road, Plot No: 78/82,
Ramachandra Nagar, Dombivli (E), Thane 421 201

For Editorial, Marketing & Advertising

104 Sudama Yash
Nr: Ramkrishna Hotel, Kelkar Cross Road, Ram Nagar,
Dombivli (E), Thane 421 201
✉: ipsmaginfo@gmail.com
ipsmag@yahoo.com

Representative

Coimbatore: Rajeev Kumar, Mobile: 094431 29073

Industrial Products Source is a product news monthly publication, registered with the Registrar of Newspapers for India, RNI No: MAHENG/2004/12919.

Industrial Products Source reserves the right to use the information published herein in any manner whatsoever. The Editor/Publisher to the best of their ability have tried to check the accuracy of information published in this issue which is based on the material supplied by respective manufacturers/agents/advertising agencies.

Neither **Product News Publication** nor any of its employees will be morally or legally responsible for any errors or omission. No part of this publication may be reproduced in any form without the written permission of the publisher. All rights reserved.

Printed and Published by Mohanan Naduvalath,
and Printed at Perfect Prints,
22/23 Jyoti Industrial Estate, Noori Baba Darga Road,
Near Makhmali Talao, Thane 400 601, and Published from
A/10 Jayshree Laxmi Puja CHS Ltd., M.E.S. Road,
Plot No: 78/82, Ramachandra Nagar,
Dombivli (E), Dist: Thane 421 201
Editor : Mohanan Naduvalath,
Owner - Product News Publication
RNI No: MAHENG/2004/12919

CONVEYORS & COMPONENTS



A WIDE RANGE TO CHOOSE

- Slats in Delrin, S.S., M.S
- Multi Directional
- Universal Flex
- Stackable
- Min / Backline Force
- Nylon, MS, SS Sprockets
- Brackets + Guides
- Clamps for Photo Cells
- Cartonator Pockets
- Tripod & Bipod
- Modular Supports

 **moldex corporation**

A-9, New Empire Industrial Estate, Kondivita Road, J.B. Nagar

Andheri (E), Mumbai 400 059

Phone: 022 - 4015 5959 • Mob: 99200 52389

E-mail: info@moldex.in / krish@moldex.in

Website: www.moldex.in

baltur INDUSTRIAL BURNERS
Energy for People

Bring to you by: **NIRMAL ENERGY LTD., AHMEDABAD** Authorised & Exclusive Rep. for INDIAN sub-continent:

- Oil / Gas / Dual Fuel Burners / Biogas / Syngas / Hydrogen & Special Fuel Burners.
Baltur S.p.A., Italy for its Energy Efficient, High Technology, Oil/Gas/Dual fuel Burners.
- Capacity ranging from 16.6 KW to 80000KW
 - Low NOx and Low CO emission class III & IV defined according to standard EN 676
 - Excellent Quality / Price Ratio, High Efficiency
 - Many different version/execution like single stage / two stage / Mechanical Modulation / Electronic Modulation / Combustion Management System with O2/CO Fan Controls and more.....
 - Retrofitting of Heating Equipment, Boilers, heaters, Gas Train components, Ring Main systems
 - Heating Equipment, Custom-Built & Heat Transfer Equipment, Spares & Accessories

Industrial Dual Block Burners with Separate Fan & Flame Geometry:

IB & TBR Series:

Fuel: Gas, Light Oil, Heavy Oil and Dual Fuel, Pre-heated air burners
IB Series up to 24 MW and TBR Series up to 80 MW

HEAT TRANSFER FLUIDS - MAXOTHERMIE® RANGE OF PRODUCTS

- Maxothermie® - 550 : Temp Range: -10°C to 305°C Extended to 315°C;
- Maxothermie® - 600 : Temp Range: -10°C to 320°C;
- Maxothermie® - HHF: Flushing Fluid
- Maxothermie® - FP : Temp Range: -10°C to 320°C
- Maxothermie® - 660 : Temp Range: -7°C to 350°C
- Maxothermie® - VPI : Temp Range: -12°C to 400°C

Maxothermie® M
Synthetic Heat Transfer Fluid

NIRMAL
Technology for Future

NIRMAL ENERGY LIMITED (An ISO 9001:2015 Certified Company)

Corporate Office: 402, ISCON Elegance, Nr. Jain Temple, Prahladnagar Cross Roads, S.G. Highway, Ahmedabad 380 015, Gujarat • Tel: 079-6616 8944 • Telefax: 079-6616 8945

E-mail: info@nirmalenergy.com / salesadmin@nirmalenergy.com / burnersales@nirmalenergy.com

Website: www.nirmalenergy.com

Services & Projects Support Office: **NIRMAL ENERGY LIMITED / NIRMALENERGY ENCON SERVICES**

CU/14-16, Swetang Complex, Jodhpur Village Road, Satellite, Ahmedabad 380 015, Gujarat

Tel: 079-2692 3170 / 2692 2315 • Fax: 079-2692 3469 • Mobile: 99879 14903 / 98258 04925

E-mail: info@nirmalenergy.com / nirmalenergy@nirmalenergy.com / service@nirmalenergy.com

AHMEDABAD: Mr. Shankar Pillai / Mr. Arvind Modgil - Cell No. 99789 84504 / 98258 04923; BANGALORE: Mr. Arvind Modgil / Mr. Shankar Pillai - Cell No. 99258 04923 / 98789 84504; CHENNAI: Mr. Arvind Modgil / Mr. Shankar Pillai - Cell No. 99258 04923 / 98789 84504; DELHI: Mr. Arvind Modgil - Cell No. 98258 04923; HYDERABAD: Mr. Chaitanya Lakkaraju / Nirmal Madhusoodanan - 94408 10646 / 97121 49505; INDORE: Mr. Arvind Modgil / Nirav Patel - Cell No. 98258 04923 / 98258 04925; KOLKATA: Mr. Krishnendu Ghosh / Mr. Arvind Modgil - Cell No. 94330 18350 / 98258 04923; MUMBAI: Mr. Arvind Modgil / Mr. Rajiv Mishra - Cell No. 99258 04923 / 99789 84501; PUNE: Mr. Abhijit Bhoskar - Cell No. 70301 10839 / 99789 84504



Dealership Enquiries are Solicited From Unrepresented Areas

Submersible Vortex Sewage Pumps PSNC/PSNCV Series

MBH Pumps offers Submersible Vortex Sewage Pumps PSNC/PSNCV Series. Technical Specifications – Head: Up to 40 m; Capacity: Up to 120 m³/hr; HP: 1 to 15; Solid Size: Up to 75 mm; MOC: Cast Iron; Frequency: 50/60 Hz. Applications: Sewage Management; Accumulated Water; Septic Tank; Drainage of Wastewater from the Attenuation Tank; Purifying Tank; Sewage Tank in Water Treatment plant. MBH's products range includes: Submersible Cutter Pumps, Submersible Grinder Pumps, Submersible Portable Pumps, Submersible Polder Pumps, Submersible Sewage Pumps, Submersible Centrifugal Pumps, Submersible Dewatering Pumps, Submersible Contractor Pumps, Duplex Steel Submersible Pumps, Submersible Bore well Pumps, Submersible Monoset Pumps, Tough Pumps Dewatering, Autoprime Pumps, Centrifugal Self-Priming Pumps, H₂O Series Horizontal Split Casing Pumps, H₂O Series Centrifugal End suction Pumps, etc.



Contact:

MBH Pumps (Gujarat) Pvt Ltd
Plot No: 14, GIDC Indl Estate, Naroda
Ahmedabad, Gujarat 382 330
☎ 079 – 2282 3066 / 2282 1018
E-mail: marketing@mbhpumps.com

Pressure Boosting Pump

Sharp Pumps Pvt Ltd offers Pressure Boosting Pump. Its Technical Data – Voltage and Phase: 220 V - 1 Phase, 415 V - 3 Phase; Insulation Class: F; Protection Class: IP68; Speed: 2880 RPM; Frequency: 50 Hz; Casing: FG 200, CF 8; Impeller: SS 304, and SS 316. Performance Data – Flow Rate: 1 m³/h to 16 m³/h; Pressure Range: 10 kg/cm²; Pipe Size: Up to 50 mm. Usage/Application: Industrial; Pressure Boosting Systems; Pressure Jet Cleaning; Water Distribution; Refrigerant Re-cycling; Very light and non-aggressive Chemicals transfer.



Contact:

Sharp Pumps Pvt Ltd
Point Arcade, Sharp Nagar, Nehru Nagar West, Kalapatti
Coimbatore, Tamil Nadu 641048
Mob: 90477 77757 / 97861 97100
E-mail: info@pointpumps.com

ELMECH[®]

Engineering Excellence In Material Handling



ELMECH is a leading material handling equipment manufacturer, for last 43 years, with expertise in engineering & manufacturing quality products. EDDYCRANES is now reaching new horizons by providing wide range of Cranes, Electric Hoists, Grab Buckets etc... ELMECH cranes are designed & manufactured by qualified engineers to suit Indian & International Standards. **Our Aim: Give us a runway & we will lift the world.**

Product Range : EOT & HOT Cranes, Goliath & Grabbing Cranes, Steel Mill Duty & Explosion Proof Cranes, Circular & Jib Cranes, Electric Hoists, Grab Buckets, Winches etc.

Salient Features : • Capacity Up To 150 Tonnes • Fail-Safe Brakes • Geared Coupling • Helical Gear Boxes • Conical/ Modular Hoists • Radio Remote Control • Variable Frequency Drives • Anti Collision Device • Prompt Delivery & After Sales Service.

Valued Customers : AL BANNA ENGG, ALGHANIM INTERNATIONAL, ANDHRA PRADHESH PAPER MILLS, ASIAN GRANITO, ASL ENTERPRISES, BAJAJ AUTO, BAY FORGE LTD, C.S.CONSTRUCTION CO., CLOUGH ENGG, DODSAL ENGG, DIFFUSION ENGINEERS, ESSAR GROUP, EURO CERAMICS, FINOLEX CABLES, GHCL, INDIAN SUGAR & GENERAL ENGG., IOL CHEMICALS & PHARMACEUTICALS, IVRCL, JINDAL POLYESTER, KALYANI FORGE, KHANNA PAPER, KHARAFI NATIONAL KSC, KIRLOSKAR BROTHERS LTD., LARSEN & TOUBRO LTD., MITTAL PRECISION AUTOCOMPS, NELCAST LTD., P.L.RAJU CONSTRUCTIONS, P.T.INDO BHARAT RAYON, PUNJ LLOYDS, ROURKELA CONSTRUCTIONS PVT. LTD., SBM PROJECTS, SERMO PM INDIA, SHREE VAISHNAV, SINGHBHUM, TECHNO ELECTRIC, THYSSENKRUPP, VACMET, WALCHANDNAGAR INDUSTRIES, etc.

Registered With : DNV, DRDO, PDO, KOC, L&T, etc.



ELMECH
ENGINEERS



• **Ads.:** 3/27, Tardeo A/C Market, Tardeo, Mumbai 400 034. INDIA
• **Tel.:** +91-22-2352 2710 / 5103 / 1798 • **Fax:** +91-22- 2352 1886
• **Email:** info@elmechengineers.co.in
• **Website:** www.elmechengineers.co.in

Hem/EL24/HP47

Control Cables

Empire Cable Industries supplies Control Cables that are used for control circuits in power plants and other similar industrial installations and signaling network of railways, with or without FR/FRLs properties in sizes normally up to 61 cores. Voltage grade is 650/1100 V (U0/U); and provided with ISI marking against IS 1554 (Pt-1). The cables conforming to standard specifications like IS 1554 (Pt-1), BS 6346, IEC 227, etc. Configuration: Multi-core/Multi-pair. Construction: Conductor – solid/stranded, circular annealed, bare/tinned copper wire of 1.5 sq mm, 4.0 sq mm. Insulation is PVC, and fully color coded cores. Core identification by printed numerals/letters is also available on request. Screening by copper braid or aluminium mylar tape of aluminium wire for reinforced armour types. Drain Wire of solid/stranded, bare/tinned copper wire normally provided. Mechanical protection: Galvanized steel wire or strip for double helical steel tape armour; Inner and outer sheath.



Contact:

Empire Cable Industries (P) Ltd
Plot No: 115, Phase-II, Badli Industrial Area, Delhi 110 042
☎ 011 – 2387 4632
E-mail: empirecables@yahoo.co.in

Torque Flow Pumps

Sintech Pumps supplies Torque Flow Pumps. Torque Flow Pumps are very suitable where normal stock pumps cannot handle liquids due to plugging or abrasive wear. The principal of the hydrodynamic liquid coupling is used for the energy transfer to the pumping liquid. The impeller generates a whirlpool in the casing and this whirlpool acts as a pumping element (impeller) in the casing. Specifications – Discharge Sizes: ND 25-500 mm; Capacity: Up to 1500 m³/hr; Head: Up to 100 m; Solid Handled: Up to 250 mm. Features: Un-obstructed passage to the discharge size of the pump; Handles large solids and long fibers; Gentle pumping action, no flocks/crystal damage; Low maintenance cost, no sealing rings on impeller, no small clearances to be maintained; Handles abrasive slurries; Handles vulnerable products like vegetables, fish, crystals etc.; Vibration free running due to hydraulically balanced construction; and Low leakage.



Contact:

Sintech Precision Products Limited
C-189 & 190, Buland Shahar Road Industrial Area
Site No: 1, P B No: 92, Ghaziabad, Uttar Pradesh 201 001
☎ 0120 – 417 6000 / 286 6320 • Mob: 93190 83345
E-mail: sales@sintechpumps.com

Liquid Ring Vacuum Pump/ Compressor VWS Series

PPI Pumps Pvt Ltd supplies a wide range of products that fulfill the exact requirements of customers. The different designs of pumps are developed to suit different industry and process specific requirements. Specifications of Liquid Ring Vacuum Pump/Compressor VWS Series – Suction Capacity: 8 to 2150 m³/hr; Power Consumption: 0.75 kW to 75 kW; Maximum Vacuum: 710 mm of HG (G); Maximum Discharge Pressure: 1.5 bar (G). This pump is widely used in Chemicals, Pharmaceuticals and Process industries. PPI Pumps products range includes: Two Stage Vacuum Pump, Close Couple Vacuum Pump, Dry Screw Vacuum pump, Liquid Ring Vacuum Pump/Compressor, Single Cone Vacuum Pump, Extraction Pump/Filtrate Pump, Two Stage Vacuum Pump, Oil Ring Rotary Vane Vacuum Pump, etc.



Contact:

PPI Pumps Pvt Ltd
Gr Floor, G S Between Plot No: 16 &
Prashant Gamatex Pvt Ltd, Phase 1, GIDC Industrial Estate
Vatva Ahmedabad, Gujarat 382 445
☎ 079 – 4008 3251 • Mob: 99040 47775 / 99040 67775
E-mail: sales@pipumps.com

Liquid Ring Vacuum Pumps & Compressors for Thermal Power Plants

Garuda Pumps Private Limited offers a range of Liquid Ring Vacuum Pumps and Compressors in different Series for Thermal Power Plants. The products range are: 2GE 1/3 and



4 Series Liquid Ring Vacuum Pump (Flat Port Type) – Suction Capacity Range: 500 m³/h to 36000 m³/h. Vacuum Range: Up to 690 mmHg; and Power Rating: Up to 750 kW. The GXL Series Liquid Ring Vacuum Pump (Conical Port Type) – Suction Capacity Range: 500 m³/h to 17000 m³/h; Vacuum range: up to 660 mmHg; Power Rating: Up to 500 kW. GAT Series (Two Stage – Conical Port Type) – Suction Capacity Range: 600 m³/h to 4800 m³/h, and Vacuum Range: Up to 740 mmHg. Also offered End Suction Centrifugal Pumps/Slurry Pumps; Twin Lobe Compressors/Blowers (Air and Water Cooled Type).

Contact:

Garuda Pumps Private Limited
Plot No: 375/1, Phase IV, B/h: New Nirma, GIDC
Vatva, Ahmedabad, Gujarat 382 445
Mob: 99790 18430 / 76000 63751
E-mail: sales@garudapumps.com

Belt Tumbler (Tumblast) Type Shot Blasting Machine

MEC SHOT, a renowned name in Design, Development and Manufacturing Surface Preparation, Finishing, Shot Peening Machines, Media Conveying, Blast Room, Paint Booth and Dust Collectors and Accessories. MEC SHOT,



provides services of Air Operated Abrasive Blasting/Airless Shot Blasting and Shot Peening machines to various industries in India as well as globally since 1992. MEC SHOT offers various types of Custom-built Automated or Semi-Automated machines, Dust Collectors and Accessories to Industries for achieving different substrate finishes, surface preparation, de-burring, de-flashing, peening

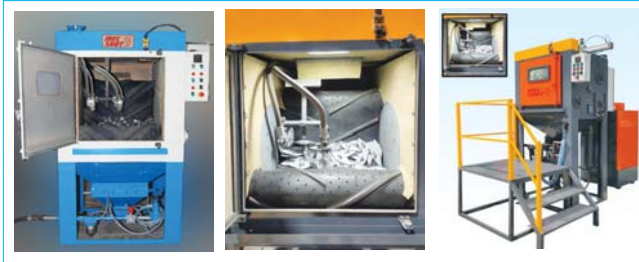

with protection and safeguarding of working environment and human resource. The customers are finding that MEC SHOT machines are cost effective by way of purchase or in operation. The rugged design shot blast machines increases production, improves quality and reduces costs, Faster and better Shot Blasting leads to faster machining, saving of power, cutting tool cost, reduces rejections. The tumble blast machine is fitted with endless Rubber Conveyor Belt gives gentle turning of the parts to be shot blasted. The shot blasting is suitable for the batch processing of large quantities of small jobs for foundry, forging, aluminium deburring, surface preparation. Features: Batch processing with 100% batch integrity; Uniform blast media circulation; Integrated anti-static spray system; Compatible with Fabric Bags/Polyester Bags and Cartridge/Pleated Filter Dust Collector; Processing spectrum includes small, large, and even complex work pieces; High process consistency with automatic monitoring systems (e.g., drives) and automatic blast media replenishment systems; Optimum, multi-stage blast media cleaning via blast chamber extraction and screen systems.

Contact:

Mec Shot Blasting Equipments Pvt Ltd
B-14, Parshvnath Indl Estate Yojna, Khasra No: 160
Mogra Kalan, Tehsil Luni, Jodhpur, Rajasthan 342 802
☎ 0291 – 274 0609, 274 4068
Mob: 70147 31363
E-mail: mail@mecshot.com

Liquid Ring Vacuum Pumps



- Wide Range-Capacities upto 36,000 m³/hr
- Vacuum System Audits
- Vacuum Pumps Efficiency Tests
- Worldwide Installations In Over 40 Countries

PL 904 SERIES

PL SERIES

PSC SERIES

VWS SERIES

VWS II SERIES

PTC SERIES

PRV SERIES

PPI SYSTEMS

PPI VACUUM PUMPS
Since 1975

G.S. Between Plot No 16 And Prashant Gamatex Pvt Ltd
 GIDC, Phase-I, Ahmedabad, Gujarat 382 445
 Phone: (079) 40083253 / 9904067775
 Email: sales@ppipumps.com | www.ppipumps.com
 Branch Offices: Delhi | Mumbai | Kolkata | Chennai | Bangalore | Hyderabad | Gajraula

Renowned For Reliability & Service World Wide

Member  





1st in INDIA
 TO INSTALL 100 HP ENERGY EFFICIENT
 AERATORS INSTALLATION AT
 M/S. AUROBINDO PHARMA LTD. - Vizag Plant

SAVE 20% to 70%

Energy by installing
 new Generation of
**ENVIRON ENERGY EFFICIENT
 AERATORS**

LIST OF MACHINERIES MANUFACTURED

Fixed & Floating Type Slow Speed Energy Efficient Aerators from 2HP to 150HP Ratings.		Centre Drive Clarifiers, Clariflocculators from 2M Dia to 25M Dia.	
			
Thickeners, High Rated Solid Contact Clarifiers (HRSCC) from 2M Dia to 20M Dia.			
	Thickener	HRSCC	Flocculator

220+ VALUABLE CLIENTS WHO HAVE OFFERED REPEATED ORDERS





ENVIRON ENGINEERING COMPANY
A Company with a tradition of Innovation (since 1977)

864/B/3, G.I.D.C. Industrial Estate, Nr. G.C.E.L., Makarpura, Vadodara - 390 010. (INDIA)
 Mobile : 098250 08442 / 98797 88102
 Mobile : 098985 48201
 Web : www.environengg.com

Peripheral Turbine Mag Drive Pumps

Shanbhag Engineering Company offers M PUMPS – Peripheral Turbine Mag Drive Pumps. Features: Balanced Impeller Design – features a hydraulically balanced floating impeller, ensuring even pressure build-up on both sides for optimal performance. Operation Range: Deliver flow rates 0.3 to 8 m³/hr, heads up to 90 m, and withstands temperatures up to 400°C. Advantage over centrifugal: Designed for low flow, medium-head applications, eliminating the need for bypass and reducing cavitation risks commonly found in standard centrifugal pumps. Self-Priming Nature: Off-center suction port, so the casing maintains a constant liquid fill, granting the pump self-priming capabilities. Stable Flow: Exhibits minimal flow variation in response to system head changes, outperforming the drooping curve characteristic of centrifugal pumps, and negating the need for impeller trimming.



Contact:

Shanbhag Engineering Company
B-50 Nandbhuvan Industrial Estate, Mahakali Caves Road
Andheri (East), Mumbai 400 093
☎ 022 – 4036 5700 / 4036 5711 • E-mail: info@shanbhags.com

AC Servo Motor Driven Pumps ASR Series

Yuken India Limited supplies AC Servo Motor Driven Pumps ASR Series. Features – High Performance: Special high power servo motor (SPM) and variable displacement piston pump. Improved ultra-low speed molding and continuous pressure holding performance and excellent repeatability. High Response: Ultra precise molding by high response injection with a high efficiency piston pump. Energy saving: Power consumption less than half that of hydraulic machines and equivalent to that of full electric machines, with reduced standby power consumption. Dual displacement models allow more compact system designs. Less wiring: Wire saving and miss wiring prevention through the integration of the controller/driver and the use of special cables. Large flow: The AMSR controller has a combination function that support operation with large flow up to 3200 L/min (ASR10 x 16 units).



Contact:

Yuken India Limited
B-80, 2nd Cross, 1st Phase, Peenya Industrial Area
Bengaluru, Karnataka 560 058
☎ 080 – 2839 0225 / 2839 0227
E-mail: marketing@yukenindia.com

Reversible Hammer Crusher

MASYC, an ISO 9001-2008 certified company specializes in the field of Bulk Material Handling System, Conveyor Equipment, Crushers and Screens etc. The Reversible Hammer Crusher is manufactured based on proven technology and under in-house strict quality control. It has the unique design feature such as Welded Casing, Screwed Liner with High Carbon Steel Plates, Hammer heads made of chrome alloy cast steel or manganese steel depending upon the application. Rotor shaft is made out of forged steel, Hammer grinding path with Wear Resistant Plates, which are Mechanically/Hydraulically adjustable and Dust Proof Spherical Roller Bearing. It crushes material in two stages ie, initially the material is reduced by impact between hammer and material followed by scrubbing action (attrition) against breaker plate. Masyc Reversible Hammer Mill is used for Hard Coal, Lignite, Cooking Coal, Lime Stone, Gypsum and other soft and medium hard material. These Mills are rugged in structural, design and easy to maintain, having high throughput and low wear. The maximum reduction ratio can be as high as 12:1 depending upon the WBI of the material. Masyc can offer Reversible Hammer Crusher up to a capacity of around 700 TPH and having Rotor dia 2000 mm.



Contact:

Masyc Projects Pvt Ltd
23 Community Centre, Mayapuri
Phase-1, New Delhi 110 064
☎ 011 – 2811 5453 • E-mail: masyc@masycproject.com

Platen Type Hydraulic Screen Changer

Veer Plastech Machinery offers Platen Type Hydraulic Screen Changer. Its advantages: Leak-Free operation; Fast Shift Screen Changer Optimize Productivity; Safe Operation; Fully Guarded and Electronically Inter Locked; Seal designed Eliminator Hag-up Area; Pressure Transducer and Hooter System also provides as per Customer Required; Special Design of Die, Bush for Mother-Baby Extruder M/C; Temperature proof Painted whole M/C; Easy Hydraulic System for Screen Change. Application: Plastic Reprocessing Plant; Pipe Plant; Lamination Plant; Sheet Plant; Master Batch Plant; Filler Plant; and Blow Moulding Plant.



Contact:

Veer Plastech Machinery
Plot No: 49, NK-1, Industrial Park, Bakrol-Dhamatvan Road
Bakrol, Ahmedabad, Gujarat 382 435
☎ 079 – 2281 9610 / 6525 2038
Mob: 99253 44258 / 98259 09358
E-mail: veerplastech2016@yahoo.com

Synthetic Heat Transfer Fluid, Maxothermie-550TM

Maxothermie-550 is a synthetic heat transfer fluid for the transfer of process heat in industries ranging from Textiles, Plywood, Chemicals, Vegetable oil extraction, Paper, Rubber, Road equipment, Paints, Pharma, Food, OEMs, Engineering, and allied industries. Maxothermie-550 has been specially formulated by process experts to withstand a wide range of operating process temperatures without losing its inherent service qualities and performance. Its features include: Operating process range: 14°F to 599°F; Withstand temperature Service

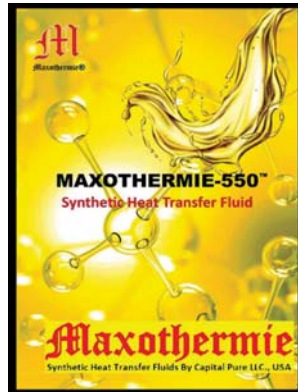

Cycles; High Resistance to Oxidation; Long Service Life; Miscible/Mixable with all mineral and Synthetic Thermal Fluid Oils. Technical Properties of Maxothermie-550: Appearance: Clear Yellow fluid; Composition: Synthetic Hydrocarbon Mixture; Maximum Bulk Temperature: 305°C (extended use up to 315°C); Maximum Film Temperature: 335°C; Kinematic Viscosity at 40°C: 19 mm²/s (cSt); Density at 25°C: 867 kg/m³; Flash Point (ASTM-D92): 193°C; Fire Point (ASTM-D92): 238°C; Auto Ignition Temperature (ASTM-D2155): 366°C; Pour Point: -40°C; Boiling Point at 1013 mbar: 351°C; Coefficient of Thermal Expansion: 0.00096/C; Moisture Content: < 250 ppm. Maxothermie-550 fluid is designed for use in non-pressurized/low pressure, indirect heating systems. It delivers efficient, dependable, uniform process heat with no need for high pressures. The high boiling point of Maxothermie-550 helps reduce the volatility and fluid leakage problems associated with other fluids. While Maxothermie-550 has a relatively high flash point, it is not classified as a fire-resistant heat transfer fluid. Consequently, the use of protective devices may be required to minimize fire risk. The insurer of your property should be consulted in relation to this matter. Maxothermie-550 has been shown to be significantly less sensitive than mineral oils to the negative consequences (sludging, fouling) of thermal oxidation systems. The recommended optimum economic bulk temperature (581°C/305°C) is based on detailed thermal studies. Operation at or below this temperature provides long service life under most operating conditions. Maxothermie-550 can be utilized up to the extended maximum use temperature of 599°F (315°C). The Company also offers other products: Medium and low temperatures synthetic heat transfer products: Maxothermie-600, Maxothermie-HFF (Hot Flash Fluid) for system cleaning; and Maxothermie-FP (Food Grade).

Contact:

Nirmal Energy Limited
402 ISCON Elegance, Nr: Jain Temple, Prahladnagar X Roads
S G Highway, Ahmedabad, Gujarat 380 015
☎ 079 – 6616 8944 • Mob: 98258 04923, 99789 84510
E-mail: info@nirmalenergy.com

Rotary Twin Gear Pump, Type RDRN

Del Pd Pumps & Gears (P) Ltd offers RDRN Type Rotary Twin Gear Pump suitable for Fuel oil, Lube oil, Veg oil, Mineral oil loading-unloading and transfer applications.

This pump is well-known, widely accepted in all the industries for its efficient performance, operational reliability, compact design and noiseless operation. Many imported gear and screw pumps are replaced with Rotodel pumps



in power stations, steel plants, refineries, oil installation on navy vessels and cargo ships. RDRN Series twin gear pump now offers enlarged capacity range with option of self or independently lubricated jacketed or non-jacketed construction with all sizes designed to run at synchronous speed of 4-pole prime mover to further reduce the overall cost of the pump set. Size: From ½" to 6" NB (Flanged to ASA 150 Class); Capacity from 0.5 to 200 m³/hr; Pressure up to 11 kg/cm²; Viscosity up to 1,00,000 cst; Temperature up to 110°C.

Contact:

Del Pd Pumps & Gears (P) Ltd
Plot No: 113, GIDC Estate, Wadhwan City
Surendranagar, Gujarat 363 035
☎ 02752 – 243 047, 243 678 • Mob: 99988 17576
E-mail: info@delpump.com

Goliath/Gantry Cranes

Tacklers Engineering Pvt Ltd (formerly known as Techno Industries) manufactures Goliath/Gantry Cranes. TACKLERS' heavy duty Gantry Crane is the ideal material han-



dling equipment for various industries and project like maintenance Factories, Power Stations, Large Water Works, Railway Yards, Harbours, Warehouses, Construction Sites, Transporters, Mines, Quarries, Heavy Fabrication Units, Contracting Firms, etc. It finds numerous applications such as loading and unloading trucks, heavy pipe laying in trenches, erection of bulky equipment, shifting of heavy load, etc. The Crane capacity is from 1 ton to 80 tons.

Contact:

Tacklers Engineering Pvt Ltd
Plot No: 613, Phase-IV, GIDC, Vatva
Ahmedabad, Gujarat 382 445
☎ 079 – 4032 3330 • Mob: 93287 39901, 93770 39904
E-mail: info@technoind.com

Jib Cranes

Reva Industries India Pvt Ltd, an ISO 9001-2015 Company manufactures Jib Cranes, which are also called Pillar Cranes are used where materials are to be handled within a circle. The rotation on the Pillar is usually up to 270 degrees but 360 degrees rotation could be provided. The Jib Cranes are very versatile in handling materials to and from machining bays, small part assembly shops, hammer/press shops and repair bays, etc. Compared to overhead cranes, which are meant to handling heavier and bulky materials, the Jib Cranes are very useful for faster operation. They can be hand operated also but, electrically operated Cranes with Electric Wire Rope Hoists, are the order of the day for increasing the production. The lifting capacity could be in the range of 1 ton to 10 tons. Reva's products range includes: EOT Cranes, Double Girder Cranes, Single Girder Cranes, Underslung Cranes, Underslung Double Girder Cranes, Electric Hoists, High Lift Hoists, Low Headroom Hoists, Jib Cranes, Pillar Mounted Jib Cranes, Wall Mounted Jib Cranes, Goliath Cranes, Stacker Cranes, Traverser, Tandem Operation Cranes, Flame Proof Cranes, Circular Cranes of different sizes and capacities. The Company served segments like Thermal Power, Nuclear Power, Hydro Power, Railways, Hazardous Areas, Oil and Gas, Paper, Cement, Ports, General Fabrication, Steel Plants, Fertilizers, etc.



Contact:

Reva Industries India Pvt Ltd
Plot No: 28, Sector 25, Faridabad, Haryana 121 004
☎ 0129 – 418 5403 • Mob: 06503 91334
E-mail: reva@revacranes.com

Organic Acid Based Degreasing Chemical

Elite Aquachem offers Organic Acid Based Degreasing Chemical – ULTROX 1750: Mild organic acid based water soluble product, provides excellent cleaning and shining to SS Tubes, and ULTROX 1800 – Strong organic acid water soluble product for cleaning and polishing of SS Tubes. This specialized product for final cleaning of tubes before dispatch. The product is suitable for Bi-Polar system of cleaning; highly economical and instant cleaning action. Applications: For the final cleaning of SS Tubes before packing and dispatch. Instant cleaning action and gives a shining surface. A ratio of 10-20% in water has to be maintained for the effective cleaning.

Contact:

Elite Aquachem
1&2 Sutirth, Sagar Signature, Waliv-Phata, Sativali
Vasai East, Dist: Palghar, Maharashtra 401 208
Mob: 93200 03592 • E-mail: eliteaquachem21@gmail.com

Direct Gauges

R K Dutt Concerns, an ISOP 9001 Certified Co offers Heavy Duty Tubular Gauges. Its operation: Level is seen thru heavy wall Borosil glass tube, protected by heavy duty box type guard made out of steel channels. Ends sealed by PTFE bolted gland. Bolted construction ensures long life. Versions: Heavy Duty Eco-Gauge. Options: Auto shut off Ball check; Isolation Valves; 16 mm and 19 mm Borosil Glass; Scales – Aluminium/SS/Acrylic; Drain/Vent Valves; Acrylic Cover. Speciality: Bolted gland design with Box Type heavy duty steel protection or Corrosion resistant and light weight FRP Guard. Features – MOC: CS, SS, PP, PTFE; Op. Press.: Abs, Vacuum to 8 bar. Range: Up to 3000 mm; Op. Temp.: 0° to +120°C. Applications: Simple liquids in small tanks, Water, Acids, Alkalis, Solvents, and Oils.

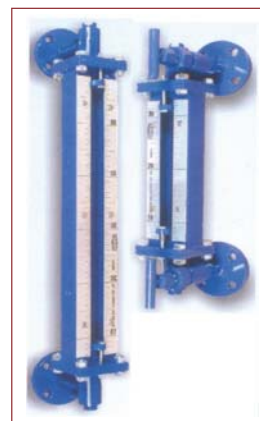

Contact:

R K Dutt Concerns
A-88 Road 18, Wagle Estate, Thane 400 604
☎ 022 – 6724 8787 / 2582 2541
E-mail: marketing@rkdutt.com

PFA/Antistatic PFA/FEP/PVDF/PP HDPE Lined Pipe Fittings

Dipflon Engineering & Co, an ISO 9001:2015 Certified Company offers PFA/Antistatic PFA/FEP/PVDF/PP HDPE Lined Pipe Fittings. All Types of Lined and Moulded Fittings



available in – MOC: DI/WCB/CF8/CF8M/CF8MI; Lining Material: PFA/Antistatic PFA/FEP/PVDF/PP; Flange Connection: as per ANSI B 16.5/BS 10 Table/DIN Rating. The

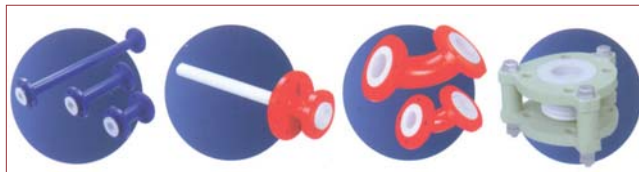

products range are: Lined Tee, Lined V Type Strainer, Lined Basket Type Strainer, Lined Double Window Sight Glass, Lined Spool Pipes, Lined Dip Pipe, Lined Elbow, and PTFE Expansion Bellow.

Contact:

Dipflon Engineering & Co
B-413, B G Towers, Nr: Delhi Darwaja
Shahibaug Road, Ahmedabad, Gujarat 380 004
☎ 079 – 2562 4003 • Mob: 98987 94440 / 92276 84378
E-mail: info@dipflon.com

Oil Sealed Rotary High Vacuum Pump

Promivac supplies Oil Sealed Rotary High Vacuum Pump, which is Single and Double Stage, Air and Water Cooled. Features: Highly compact in design and yet so simple at the same time. Most reliable and efficient performer. An indispensable equipment for Pharmaceutical, Petrochemical, Cosmetic, Oil Refinery, Automobiles, Food, Flavors and Fragrances, Refrigeration, Chemical, R&D Centers, Scientific Labs, Pilot Plants, Vacuum Systems and host of industrial units. Applications: Vacuum Creation, Filling, Drying, Lifting, Forming, Filtration, Deep Freezing, Distillation, Annealing, Impregnation, Dehydration, Sublimation, Film Coating and many more. Promivac is one of the leading enterprises in the field of manufacturing and exporting of Industrial Pump, Vacuum Pump, Industrial Blower, High Vacuum Plant Systems and more. Vacuum Related Pumps became their first choice because this sector had still remained unexploited about three decades ago.



Contact:

Promivac Pumps Pvt Ltd
 3575 Netaji Subhash Marg, Darya Ganj, New Delhi 110 002
 ☎ 011 – 2328 1082 / 2327 3965
 E-mail: info@promivacpump.com

Jacketed Casing Pump

Abirami Engineering Company provides a complete Solution for all Liquid Handling. The Jacketed Casing Pump Type APC-JT is a Chemical process pump with jacketed casing for High temperature application. Casing, stuffing box jacketing with triple bearing design. Operating Range – Capacity: Up to 800 cum/hr; Head: Up to 160 m; Temperature: Up to 240°C; Working Pressure: Up to 25 kg/cm²; Speed: 3600 RPM max. Type of Sealing: Gland packing to withstand high temperature. Also available with Mechanical seal of special cartridge type. Lubrication: Special Synthetic grade oil suitable for high temperature operation. Abirami products range includes: Process pumps, Gravity Flow pump, Vertical Inline pump, Vertical Slurry pump, Vertical Cantilever pump, Water pump, High Pressure pumps, Gear pumps, Dosing/Metering pumps, Progressive Cavity pump, etc.



Contact:

Abirami Engineering Company
 25 Vivekanantha Nagar, Street No; 1, P N Pudur
 Coimbatore, Tamil Nadu 641 041
 ☎ 0422 – 244 3813 • Mob: 93631 45603 / 93623 45603
 E-mail: abiramipumps@yahoo.com

a unique innovation, with trust and quality...

Commercial Gauges	Industrial Gauges	Low Pressure Capsule Gauges	Economical Gauges	Chemical Sealed Gauges	Compact Sealed Gauges	Gauge Saver
Triclover Sealed Gauges	Homogenizer Gauges	Mud Gauges	Bi-Metallic Temperature Gauges	Comparison Tester	Comparison Tester	Needle Valves

Manufacturers of Pressure Gauges, Temperature Gauges, Testing Equipments & Accessories

ARBUDA INSTRUMENTS

Office : E-11/1, G.I.D.C., Sector-26, Gandhinagar - 382 026 (Gujarat)
 Telefax: 079 - 2328 7990 • Mob: 090337 11390 / 093282 97128
 E-mail: arbudainst@yahoo.com • Website: www.arbudainstruments.com
 Mumbai Office : 23/25, Maruti Mandir Marg, Mumbai - 400 004
 Tel.: 022 - 2382 4101, 6636 2754

Syphons

Power Cables

Empire Cable supplies power cables with PVC insulation for power transmission. Voltage grade 650/1100 volts (Uo/U) provided with ISI marking IS 1554 (Pt-1), with or without HR/FRLs properties. Screening can be provided if desired. The cables conform to standard specifications like IS 1554 (Pt-1), IEC 502, BS 6436/87. Configuration: Single core up to 1000 sq mm, multi-core up to 400 sq mm x 3-1/2 cores; Construction: Conductor is aluminium/copper, solid/stranded circular/compacted/sector shaped. Insulation is PVC; Mechanical protection: Galvanized steel wire/strips/double helical steel tape; aluminium wire amounting for single core cable; Inner and outer sheath – PVC black/grey or as per requirement.



Contact:

Empire Cable Industries (P) Ltd
Plot No: 115, Phase-II
Badli Industrial Area, Delhi 110 042
☎ 011 – 2387 4632 • Fax: 011 – 2386 1610
E-mail: empirecables@yahoo.co.in

Gate Valve API 6D

Jayant Engineering offers API 6D Gate Valve. Design Features – Design and Manufacturing: API 6D; Inspection and Testing: API 6D; Inspection and Testing: API 6D; End Flanges dimension: ASME B 16.5; BW end Dimension: ASME B 16.25; Face to Face and End to End Dimension: API 6D ASME B 16.10; Design: SLAB Type, through conduit passage – Piggable; Anti-friction ball thrust bearing in yoke sleeve; Drain and Vent Connection, Lifting Lugs and Support Legs, Double block and bleed, fire safe design. Special Features: Gear Operation – applied force exceeds 350N; Limit switch arrangement; Electrical and Pneumatic arrangement; Position indicator; Locking arrangement; Fugitive Emission test; Resilient seal; NACE MR 0175 and MR 0103; Pneumatic Actuator. Tolerance – Face to face: ± 2.0 mm for NPS 10" and ± 3.0 mm for NPS e" 10".



Contact:

Jayant Engineering & Marketing Pvt Ltd
Plot No: 2003/2004, Phase II, GIDC Chhatral
Tal: Kalol, Dist: Gandhinagar, Gujarat 382 729
☎ 02764 – 234 053 / 232 182 • E-mail: sales@jayantvalves.com

Eccentric Disc Pumps

Mascot Systems Private Limited offers Eccentric Disc Pumps in different Series. Eccentric movement technology is at the core of Mouvex®. Mouvex founder, Andre Petit, identified the challenges that gear pump and lobe pump users were facing in optimizing their process and invented the eccentric disc pumps as a result. Mouvex® G-FLO Seal-Less Eccentric Disc Pumps offer premium performance and complete containment for chemical and industrial applications. Key features include: High flow rates – up to 70 m³/h (300 gpm), 10 bar (145 psi). Mouvex® C Series Eccentric Disc Pumps are perfect for air and shear sensitive products. With a seal-less design and double stainless-steel bellows, they ensure durability and safety. High suction and discharge pressures enable self-priming and full line stripping for optimal product recovery. Applications: Food, Beverage, Cosmetic and Pharmaceutical. The Company also offers Seal Less Pumps H-Flo Series, S Series, and Micro C Series.



Contact:

Mascot Systems Private Limited
801 Ambience Court, 8th Floor, Plot No: 2, Sector-19D
Palm Beach Road, Vashi, Navi Mumbai 400 703
☎ 022 – 4122 6500 / 4122 6501
E-mail: sales@mascot-systems.com

Mechanical Pneumatic Level Control MPN

Machine House (India) Pvt Ltd offers Mechanical Pneumatic Level Control MPN. Bilz level control systems are significant components in the optimum function of vibration insulation using FAEBI® and FAEBI®-HD rubber or BiAir® membrane air springs. They prevent impermissible and undesired deflection of the insulators or an out-of-level condition of the machine that can be caused by load changes on an air spring mounted machine or system. Rapidly adding or venting air enables the air pressure within the air spring to be matched to the respective load, automatically controlling the height of the individual air springs. This enables the highest degree of stability and effective insulation even with changes in the centre of gravity.



Contact:

Machine House (India) Pvt Ltd
D/1/18, MIDC, Ambad, Nashik, Maharashtra 422 010
☎ 0253 – 237 0662 • Mob: 98223 95213 / 99229 94859
E-mail: bilzindia@gmail.com

Pneumatic Products

ACE Flow Konzepts Pvt Ltd, an ISO 9001: 2015 Certified Company manufactures different range of Pneumatic Products for different applications. The products range are: Air Nozzles, Air Blowguns, Air Flow Vac; Air Wipes, Vortex Tubes, Machine Tool Cooler; Air Amplifier, Hand Vacuum Gun, Cabinet Cooler; Air Jets, Air Knife, Pneumatics Piston Vibrator, etc. Applications: Blowing; Drying; Cleaning; Cooling; and Material Flow. The Company has tie-up with AIRMASTERS, Spain and NAVCO, USA.



Contact:

ACE Flow Konzepts Pvt Ltd
68A, New Empire Industrial Estate, Kondivita Lane
J B Nagar, Andheri (East), Mumbai 400 059
☎ 022 – 4973 8514, 2834 2079
Mob: 88283 33947
E-mail: info@aceflow.co.in

Goliath Cranes

Eddycranes Engineers manufactures ELMECH make single girder as well as double girder Goliath cranes conforming to IS: 807-1976, IS: 3177-1977, IS: 3938-1983 and IS: 4137-1963 where ever applicable. The Goliath cranes are manufactured up to 150 tonnes capacity and for 40 m span. Each ELMECH Goliath crane is built to suit specific dimensional clearance and technical requirement of the customer. The box type girder construction ensures more torsional rigidity and strength. The Grabbing crane is designed to suite indoor or outdoor location and can also be supplied with Grab buckets, electro magnets. The Goliath cranes are designed to run on forged steel wheels running in L-type housing having antifricition roller bearings. The hoisting machinery consist of square cage/slipping motor, totally enclosed oil lubricated spur/helical gear box, thrustor brakes, geared coupling, rope drum, etc. The cranes are suitable for control from floor by means of pendant controller or from driver's cabin by means of master controllers or through radio remote control. The Goliath cranes can also be supplied with cantilever arms to lift over hanging material. ELMECH Goliath cranes are supplied in Cement plants, Thermal and Hydel Power stations, Granite industry, and general engineering industries, etc.



Contact:

Eddycranes Engineers (P) Ltd
3/23 Tardeo A/C Market, Tardeo, Mumbai 400 034
☎ 022 – 2352 2710 / 2352 5103
E-mail: info@eddycranes.com

TC Rollers for Hot & Cold Rolling Mills

Avis Metal Industries Ltd, an ISO 9001: 2015 Certified Company manufactures Tungsten Carbide Rollers, which is used in Wire Flattening Roll, Wire Guiding Rolls, High-Speed Rolling Mills, Wire Rod Rolling Mills. TC Rollers are used for extended life in applications where long rolling campaigns are required. Their extreme hardness makes them suitable for wire rods finishing blocks and some shaping applications. The cemented carbides rolls are divided into the conventional WC-TiC and the corrosion-resistant alloys with a mixed binder Co-Ni-Cr. The binder contents vary according to the specific requirements of the application. The Company also supplies composite roll rings that are a combination of cemented carbide and steel. Unlike the relatively brittle cemented carbide rings, these rings open a wide range of applications. Avis products range includes: Tungsten Carbide Parts, Tungsten Metal Powder, TC Sleeves, Wear Parts Solution; Industrial Dies; TC Wire Drawing Pellets; etc.



Contact:

Avis Metal Industries Ltd
Opp: T B Hospital, Ashwanikumar Road
Surat, Gujarat 395 008
☎ 0261 – 255 1545 • Mob: 97377 22272 / 97377 22275
E-mail: info@avismetall.in

FITZER

World Class Product Brand

PROCESS, MEASURING INSTRUMENTS & AUTOMATION

PRESSURE

- LIQUID COLOUR MANOMETERS
- DIGITAL MANOMETER
- DIGITAL PRESSURE GAUGES
- BAROMETER
- VACCUM MANOMETER
- PRESSURE SWITCHES

FLOW

- GLASS TUBE / ACRYLIC ROTAMETERS
- METAL TUBE ROTAMETER WITH TRANSMITTER / FLOW INDICATOR TOTALIZER
- BY-PASS ROTAMETER
- ELECTROMAGNETIC FLOWMETER
- FLOW SWITCHES
- AIR VELOCITY KIT

LEVEL

- LIQUID LEVEL INDICATORS
- LIQUID LEVEL TRANSMITTER
- LIQUID LEVEL SWITCHES (FLOAT OPERATED)
- CONDUCTIVITY LEVEL SWITCHES
- CAPACITANCE TYPE LEVEL TRANSMITTERS

FITZER Regd. Correspondence Address:
 INSTRUMENTS COMPANY (INDIA) Atali, Near Ambivali Stn. (W), P.O. Mohone, Tal. Kalyan, Dist. Thane-421 102
 Mobile: 8691816354 / 8691816355 / 8691816356 / 9426470248
 E-mail: fitzerindia@hotmail.com / fitzergujarat@rediffmail.com

Dealership Enquiries Solicited
Website: www.fitzerindia.com

Single Valve Gate

Madhu Machines & Systems Pvt Ltd offers the VeriShot Single Valve Gate is the optimal solution for single socket applications. Delivered Pre-Assembled for ease of installation, VeriShot is ideally suited for applications requiring a cosmetic finish, fast flow rates and large volume parts. Features: Conical or cylindrical valve pin shut off; Compact design, reducing mould height requirements; Pneumatic actuation with high closing force; Wide moulding window, able to process most complex engineering polymers with fillers; FlowLoc threaded nozzle attaches securely to manifold; Flow channels manufactured from 420 corrosion resistant steel; Simple mould assembly; Valve pin adjustment.



Contact:

Madhu Machine & Systems Pvt Ltd
A-4/5, Anurag, Ganeshkrupa Society, Chikwadi
Haripura, Vadodara, Gujarat 390 007
☎ 0265 – 235 3886 • E-mail: meeta@madhu-group.com

Lined Valves

Hi-Tech offers the most comprehensive fully Lined Valve range in PFA, Antistatic PFA, FEP, ETFE, PVDF, PP or HDPE to provide Complete Solution to CPI and related



industries for their Corrosion problems. The range includes: Ball Valves (Integral Ball-Glandless design) max. 10" (DN 250); Plug Valves (Two way and Jacketed design) max: 10" (DN 250); Butterfly Valves (Wafer and Lug Type design): max. 28" (DN 700); Diaphragm Valves (Weir Type): Max: 10" (DN 250); Flush Bottom Valves: Max 6" x 4" (DN 150 x 100); Globe Valves: Max: 4" (DN 100); Wafer Swing Check Valve: Max 24" (DN 600); Ball Check Valve: Max 10" (DN 250). Other lined accessories like Check Valves (NRVs), Sight Flow Indicator, Sampling Valve, Strainers and many others are also available from Hi-Tech.

Contact:

Hi-Tech Applicator
1102-B, Phase-3, GIDC Ind Estate, Vatva
Ahmedabad, Gujarat 382 445
☎ 079 – 4030 7621 / 2589 1740 • Mob: 97370 46491
E-mail: hitech@ptfeindia.com

Thermoplastic Valves

UNP Polyvalves offers a range of Thermoplastic Valves like Ball Valve Lever operated, and Socket Weld/Threaded End; Butterfly Valve Lever operated, and Gear operated;



Diaphragm Valves Rising Hand wheel, Ball Check Valve, Swing Check Valve Wafer Type, Sampling Valve Sandwich Type and Flanged Type, Sight Glass Flanged End, Strainer T/Basket Type, Foot Valve Flanged End, Ball Valve (PVC/



UPVC), Butterfly Valve CPVC/UPVC; Diaphragm Valve CPVC/UPVC; Lined Valves, Lined Actuated Valves, Thermoplastic Actuated Valves, etc. Also offers Lined Pipes and Fittings.

Contact:

UNP Polyvalves
5 to 16 PR Industrial Estate, Por GIDC - Kashipura Road
Moje: Kashipura, Dist: Vadodara, Gujarat 391 243
☎ 70434 30467 / 70430 20707
E-mail: sales.baroda@polyvalve.com

Pneumatic Products

Sunbeam Industries supplies Pneumatic Actuators, Pneumatic Cylinders, Pneumatic Positioners, Ball Valves, Butterfly valves, Control valves, Limit Switches, Spool valves, and etc. Sunbeam also undertakes the repairs and maintenance works for the above mentioned products.

Contact:

Sunbeam Industries
30/1 Meghal Industrial Estate, Devidayal Road
Nr: Woodland Retreat, Mulund West, Mumbai 400 080
Mob: 98200 03244 / 93305 57208
E-mail: sunbeamindustries.org

Angle Seat Valves

Duncan Engineering offers Angle Seat Valves. These valves are available in 1/2", 3/4", 1", 1-2/4" and 2" port sizes; 2/2 function with In-line installation; Flange Type also available; Large Flow rates; Suitable for viscous and dirty media; and for high media temperatures. Duncan's products range includes: 2-Way Solenoid Valves, Flow Control Valves, ISO Valves, Quick Exhaust Valves, Pulse Valves; VDMA/ISO Cylinders, ISO Round Tube Cylinders, Small Bore Cylinders, Large Bore Cylinders, ISO Large Bore Cylinders, Hydraulic Cylinders, etc.



Contact:

Duncan Engineering Limited
F-33, MIDC, Ranjangaon, Karegaon
Tal: Shirur, Pune, Maharashtra 412 209
☎ 02138 – 660 066 • E-mail: pbu@duncanengg.com

Pneumatic Cylinders

T Series – Round Barrel Cylinders

Mercury was the first Indian manufacturer to launch VDMA/ISO type Pneumatic cylinders with a built in magnetic Piston. Today, after various technological advancements, our ISO series cylinders are the choice of many



OEMs. The special seal designs, low weight extrusions and in-house honing capabilities ensures a quality product in a very short lead time. Due to in-house manufacturing control, Mercury ISO cylinders are available in a variety of lengths ranging from 20 mm to as long as 2000 mm. Mercury Pneumatic cylinders are categorically divided into 2 series i.e. T Series for round barrel cylinders and TM Series for Round barrel cylinders with a magnetic piston. Both series have cylinders ranging from 32 mm to 100 mm bore. Double ended cylinders and Stroke adjustment cylinders are available against request. Mercury stands as a premier manufacturer and supplier of pneumatic products in India. Renowned for its high-quality and innovative solutions, the company offers a comprehensive range of pneumatic components designed to meet the diverse needs of various industries.

Contact:

Mercury Pneumatics Pvt Ltd
C-105, Ansa Industrial Estate, Saki Vihar Road
Andheri (E), Mumbai 400 072
☎ 022 – 4015 1020 • E-mail: contactus@mercuryindida.net

Pneumatic Actuators

JossMin Valves and Automations Private Limited is a premier manufacturer of a wide range of valves and advanced valve automation solutions, offers Pneumatic Actuators.

Features: Blowout proof Pinion design; Square/Bisquare Pinion for coupling with valve; External Stroke adjustment in $\pm 5^\circ$ for Open/Close positions; Unique Guide ring design ensures no Metal to Metal



contact; Minimum Pressure operation; Low Response Time. Then Actuators have a robust and compact build, designed to operate at desired air pressure with minimal frictional loss thereby ensuring Optimum Torque with no metal-to-metal contact and a quick response. Specifications – Design: as per standard; Sing-Acting: (0-90)/(-90-0+90) Rotation;



Double-Acting: (0-90) / (0 - 180); AL Extruded (HA) / Casted (Epoxy Painted) / SS (Casted); AL Die Cast Racks and E#N8 (ENP Coated) Pinion or in SS; Operating pressure range: 2.5 Bar to 8 Bar (Designed for 10 Bar); Wide range of O/P Torque; ISO 5211 and NAMUR mounted interface provided; VDI/VDE 3845 for Position Feedback modules and Auxiliary accessories. Its extensive portfolio includes Standard and well as customized Electro-Pneumatic 2-Way and 3-Way Ball Valves, Centric and Eccentric Butterfly Valves, and Flush Bottom Ball Valves. The Company is catering to diverse industries including Pharma, Food and Beverages, Chemicals and Pesticides, Paints, Polymers, etc.

Contact:

JosMin Valves and Automations Private Limited
Plot No: 2, Survey No: 46, Manas Industrial Hub Chinchpada
Waliv Road, Vasai East, Dist: Palghar, Maharashtra 401 208
Mob: 70280 25111 / 70280 25222 • E-mail: info@jossmin.co

Vacuum Systems

Economy Process Solutions Pvt Ltd is a leading provider of vacuum and process solutions in India. The Company offers a range of high-quality vacuum systems that are designed to help businesses in a variety of industries optimize their processes. Whether it is to remove contaminants and gases from products, create a controlled environment, or achieve other specific goals, we have the expertise and resources to provide the perfect solution. Economy's vacuum systems are reliable, efficient, and cost-effective, and can be customized to meet the unique needs of all businesses.

Contact:

Economy Process Solutions Pvt Ltd
1401 Vikas Centre, Gidwani Road, Chembur, Mumbai 400 074
☎ 022 – 2520 5864 / 2520 5867 • Mob: 88284 21690
E-mail: sales@economyprocesssolutions.in

Double Stage Water-Ring Vacuum Pumps

Promivac Pumps Pvt Ltd supplies Double Stage Water-Ring Vacuum Pumps Direct driven, Gland Rope/Mechanical Seal Type. These pumps are Promivac's vastly patronized Water-ring type Vacuum Pumps and develop Vacuum of 720 mm Hg. These pumps are rugged, reliable, and cost effective, and have extended service life. Available in various material combinations are a boon for industries where process vapors are a major concern. Applications: Plastics, Confectionary, Leather, Processing, Food Processing, Pharmaceutical, Chemical, Petrochemical, Breweries and Distilleries, Furnaces, Extrusion, Packaging, Tiles and Ceramic industries, Cement and Fertilizer Plants, Metallurgical Laboratories. The Company's range of products include: Oil Sealed Rotary High Vacuum Pumps, Direct Drive Rotary High Vacuum Pumps, Oil Lubricated Rotary Vane Vacuum Pumps, Water-Ring/Liquid Ring Type Vacuum and Compressor Pumps, Direct Drive Water-Ring Vacuum Pumps, Vacuum-Pressure Sludge Suction and Disposal Pumps, Vacuum-Pressure Turbine Blowers, Side Channel Blowers, Centrifugal Blowers, Twin Lobe (Roots) Blowers, etc.



Contact:

Promivac Pumps Pvt Ltd
3575 N S Marg, Darya Ganj, New Delhi 110 002
☎ 011 – 2328 1082 / 2327 3965
E-mail: info@promivacpump.com

Oil Free Vacuum Pumps cum Compressor

Avi Scientific (Bharat) LLP offers Portable Oil Free Vacuum Pumps cum Compressor. Specifications of the Model AVI-75-P – Max flow: 75 ltrs/min; Max Vacuum: 22" Hg; Max Pressure: 40 PSIg; Approx weight: 9.0 kg; Motor: ¼ HP; Approx Dimensions: 290 x 120 x 180 mm. The Company is a manufacturer and supplier of laboratory instruments, laboratory chemicals, and laboratory glassware. It also provides an in-house repair and servicing facility for lab instruments. Additionally, it has a National Accredited (NABL) Instrument Calibration Laboratory that allows it to provide calibration services for pharmaceuticals, chemicals, beverages, R&D, quality control, and more.



Contact:

Avi Scientific (Bharat) LLP
A-221, Amargian Industrial Complex
Khopat, Thane 400 601
☎ 022 – 2547 7638 • Mob: 70455 36709 / 93230 73623
E-mail: aviscientific123@gmail.com

Five Valve Manifold (T) Type

Trueway Engineering Industries offers Five Valve Manifold (T) Type Direct Transmitter mounting Type. Features: Inlet Connection: Two ½" Female NPT threads at C/C of 54 mm; Outlet Connection: Transmitter Flange having C/C of 54 mm; Drain Connection: Two 1/3" Female NPT (BSP/BSPT/ISO/Metric or any other Types of threads available upon request); MOC: SS/CS/AS/Brass/High Nickel Alloys, etc; Gland Packing: PTFE or Graphoil for High Temp Service; Accessories: Four Mounting Bolts, Two PTFE Transmitter Flange Seal Rings, Two ¼" NPT M Plug. The Company also offers Manifolds Coplanar Type, Direct Mounting Type, Manifolds for any other make of Transmitters, Monoflange Type Manifolds, and Gauge Root Needle Valves are available upon request. Trueway's products range includes: Air Headers/Air Manifolds; Ball Valves, Butt Weld Pipe Fittings, Check Valves/NRV, Gate/Globe Valves, Needle Valves; Condensate Pots; Copper Tubes; Copper Tubes with PVC; Flexible SS/Rubber Hoses; Flanges; Gauge Cocks; Impulse Tubes; Instrument Pipe Fittings; Pipes CS/SS/AS; PU/PTFE Tubes; Push Fit Fittings; Quick Release Couplings; Siphons, Snubbers, Thermowells; Tube Fittings Compression Type; Tube/Pipe Clamps, etc.



Contact:

Trueway Engineering Industries
Trueway House, Plot No: 535/14-15, Sonawala Cross Rd No: 2
Nr: M K Industrial Estate, Goregaon (East), Mumbai 400 063
☎ 022 – 2685 2241 / 2685 1052
E-mail: truewayengg@gmail.com

Close Coupled Self-Priming NSA Centrifugal Pump

DESMI India offers Close Coupled self-priming NSA centrifugal pump. The NSA Close coupled self-priming centrifugal pump is a totally renewed design based on the original "K&R" models. However, fully replaceable with former types, in dimensions as well as capacities. The compact pumps are simple in design, consist of few parts, and will thus reduce your costs. This of course also means easy maintenance. Design Features: Open impeller, exchangeable wear plate, standard stainless steel shaft and non-leaking mechanical shaft seal. Specifications: Nominal diameter (DN): 50 to 80; Flow rate – 50 Hz: Up to 70 m³/hr; Head: Up to 50 m; Pressure: Up to 12 bar (170 psi); Temperature: Up to 140°C (284°F); Motor: Standard and Ex motors; VFD: Direct or Bulkhead/Wall-mounted.

Contact:

DESMI India Private Limited
IP NADERGUL, SY No: 519, Nadergul Village, Saroor Nagar
Mandal, Dist: Ranga Reddy, Telangana 501 510
Mob: 79426 85885 • E-mail: desmi@desmi.com

Wafer Check Valves

Mawa Engineering Works offers Wafer Check Valves. Features – Design and manufacturing: API 6D; Pressure Rating: Class 150 to 2500; Pressure and temperature ratings: ASME B16, 34; Size: 25 mm to 600 mm; End connection: Suitable to mount between ASME B16.5, BS 10-Table D, E, F; Face to Face dim: API 6D; Inspection and Testing: AP 598; Material of Constructions: Cast Iron, SG Iron, WCB, CF8, CF8M, CF3M, CN7M, Hastelloy C and all alloys; Special: PTFE seated, Spring Loaded valves. Mawa's products range includes: Ball Valves, Butterfly Valves, Butterfly Valves Double Flanged, Dual Plate Check Valves, Double Block and Bleed Valves, Gate Valves, Globe Valves, Plug Valves, Strainer Y Type, Swing Check Valves, etc.

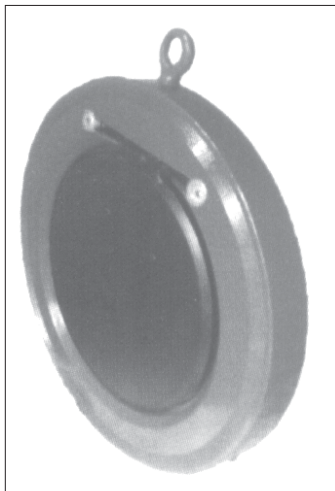

Contact:

Mawa Engineering Works

5-6 Darbar Manzil, B/h: Jai Hind Hotel

Sarkhej, Ahmedabad, Gujarat 382 210

Mob: 93270 13245 • E-mail: mawaenggworks@gmail.com

Ball Valve with Actuator 3-Way 120°

Micro Pneumatics Pvt Ltd offers the 3 way 120° Angle L-Port Ball Valve, which is designed for zero cavity, used for diverting heavy or highly viscous r slurry media. The obtuse 3-way angle path allows a free flow diversion, even material such as powder and dough conveyed through vacuum, ideally suited for vacuum conveyors. The three ports are configured on a horizontal plane for any desired valve orientation. Mounting Interface ISO 5211; MOC of the Body: CF8, CF8M, CF3, CF3M (Special on request); Trim: CF8, CF8M, CF3, CF3M (Special on request); Seat/Cavity Filler: PTFE, RPTFE (Special on request); Size: ½" to 4".



Contact:

Micro Pneumatics Pvt Ltd

Plot No: 133-134, Vasai Municipal Indl Area, Umela Phata Papdy, Vasai Road (West), Dist: Palghar, Maharashtra 401 207

☎ 0250 – 232 0458 • Mob: 83089 59200 / 83548 00888

E-mail: micropneumatics@vsnl.net

Globe Valves

VALVE-TECH, one of the leading manufacturers of superior International quality Valves, supplies Globe Valves. Its Features: OS and Y type, bolted bonnet; Design Std: BS/1873/ANSI B 16.34, Testing as per BS 6755 Part 1; Low operating torque; Face to face dimensions as per ANSI B.16.10/BS 2080; Flange drilling as per ANSI B 16.5 RF serrated, BS 4504, BS 10 and other available drilling standards; Valves with back seat arrangement; Deep stuffing box to accommodate more packing rings; Plug type disc. Products range includes: Ball Valve, Gate Valve, Globe Valve, Non-Return Valve, Butterfly Valve, Plug Valve, Strainers, etc.



Contact:

Valve-Tech Industries

Kajal Heritage Building, Kopar Khairane Sector 12

Navi Mumbai 400 709

☎ 022 – 2754 9193 • Mob: 01157 17371

E-mail: marketing@vtivalves.com

Split Case Pumps ASP Series

Dhruv Agencies supplies ANDRITZ Split Case Pumps ASP Series. Product Facts: Consistency (pulp and paper industry) up to 2%; Head up to 250 m; Flow rate up to 40,000 m³/h; Pressure up to 25 bar; Temperature up to 80°C; Power up to 7,000 kW; Efficiency up to 91%. Fields of application: Cooling water, circulation water pumps for power stations, industrial plants and district heating networks; Raw water pumps for water treatment plants; Drinking water pumps for water supply systems; Water pumps for desalination plants; Head box pumps, cleaner pumps or filtrate and water pumps for the pulp and paper industry. The Company also offers Single Stage Centrifugal Pumps ACP Series, Single-Stage Centrifugal Pumps from the ES 05 Series; APEX Series Energy Efficient Series Motors, Flameproof Motors (Agnita Series), HT Motors, Helical gear Box, Double Worm Reduction Gear Box, Single Shaft Extruder Gear Units, etc.



Contact:

Dhruv Agencies

A/109, 1st Floor, Hakimji Business Center

GIDC Char Rasta, Vapi, Gujarat 396 195

Mob: 99798 82754 / 96382 50445

E-mail: info@dhruvagencies.in

Multi-Stage High Pressure Air Cooled Compressors

Indo-Air Compressors Pvt Ltd offers Multi-Stage High Pressure Air Cooled Compressors, which are used in industries like Pet Bottling, Air Blast Circuit Breakers, Pharmaceuticals, Gas Transmission and Distribution, Defence Establishments, Shipyards, Oil Exploration, Pneumatic Testing, Engine Starting, etc. The Company's products range includes: Single Stage Low Pressure Compressors (2-8 kg/cm²); Two Stage Medium Pressure Compressors (7-17.5 kg/cm²); Oil Free Reciprocating Compressors; Reciprocating Booster Air Compressors; Oil Free Medium Pressure Water Cooled 30 to 215 HP; Rotary Screw Belt Drive (7.5 to 100 HP); Rotary Screw Direct Drive lubricated (20 to 180 HP); Reciprocating 2 to 10 HP Single and Two Stage Vacuum Pumps Dry Type, etc.

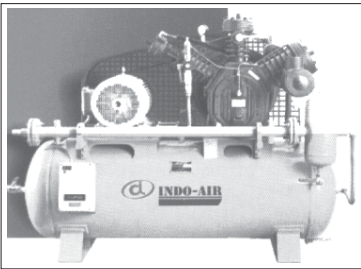

Contact:

Indo-Air Compressors Pvt Ltd
Plot No: 550, Main Road, Kathwada GIDC
Ahmedabad, Gujarat 382 430
☎ 079 – 2290 1951 / 2909 2859
Mob: 99241 03612
E-mail: info@indoair.com

Control Valve Diaphragms

Arvico Rubber manufactures and export Control Valve Diaphragms. The Company offers various types of diaphragms in different thicknesses, which can work at ex-



treme cold conditions to maintain pressure and temperature with hassle free operation. Arvico's products range includes: Actuator Diaphragms, Straight Through KB Type Body Diaphragms (Close to Open), Solenoid Valve Diaphragms, AODD Pump Diaphragms, Rolling/Cup Type Diaphragms, Dosing/Metering Pump Diaphragms, Pressure Reducing valve Diaphragms, Vacuum Pump Diaphragms, Fire Protection Deluge valve Diaphragms, Expansion Bellows, Seat for Butterfly Valve, Rubber Stators for Screw Pump, Muff for Pinch Valve, Extruded Profiles, etc.

Contact:

Arvico Rubber
104 Shanta Industrial Estate, IB Patel Road
Goregaon East, Mumbai 400 104
Mob: 90822 67081
E-mail: info@arvicorubber.com

Horizontal Chemical Process Pump / Semi-Open Impeller Process Pump

Superflow Pumps Pvt Ltd manufactures a range of pumps like Horizontal Chemical Process Pump, Cartridge Chemical Process Pump, Semi-Open Impeller Process Pump, Self-Priming Pump, Vertical Sump Pump, etc. Technical Specifications – Head Up to 100 m; Capacity: Up to 600 m³/hr; Maximum temperature: - 350°C; Mechanical Seal – Metallic Below. Applications: Effluent and Sewage plants; ETP and STP; For handling chemicals, acids, slurries, solvents, hot water; Molten Sulphur Service; Paper plants; Petrochemicals; Refineries; Steel plants; Textile plants, etc.



Contact:

Superflow Pumps Pvt Ltd
A-498, TTC Industrial Area, MIDC
Mahape, Navi Mumbai 400 710
Mob: 97691 92843 / 98210 20774
E-mail: info@superflowpumps.com

Magnetic Float Switch

Filpro Sensors Pvt Ltd offers Magnetic Float Switch, which consists of non-abrasive float carrying permanent magnet and non-ferrous stem carrying one, two, or multiple reed switches. The float glides along the stem and when the float nears the vicinity of reed switch, the magnetic field of permanent magnet forces the reed contact to close. The reed switch output are provided as potential free contacts. Features – Housing: SS 304, SS 316, PP; Float: PP, SS 316, Titanium, Nylon Foam; Mounting: Flange, Threaded; Enclosure: Weatherproof, Flameproof; Probe Length: up to 5000 mm. Maximum Temp.: 125°C; No of switches: 1 to 10; Maximum Pressure: 10 kg/cm²; Maximum Switching Voltage: 230 V AC; Maximum Switching Current: 0.7 A. Applications: Water, Cooling Tower, Hydraulic Oil, Diesel, Edible Oil, Chemical and Pharma. Filpro's products range includes: Liquid Level Indicators, Magnetic Level Indicators, Tubular Level Indicators, Side Mounted Level Switches, Float Level Transmitters, Capacitance Level Transmitters, Ultrasonic Level Transmitters, Hydrostatic Level Transmitters, etc.



Contact:

Filpro Sensors Pvt Ltd
No: 130, 10th Cross, Pete Chennappa Industrial Estate
Kamakshipalya, Magadi Main Road
Bengaluru, Karnataka 560 079
☎ 080 – 2328 6463 • E-mail: sales@filprosenors.com

Flat Submersible Cables (3-Core)

Empire Cable Industries is India's leading manufacturer of a wide range of electrical PVC insulated wires and cables, which are used by quality conscious electrical contractors and recommended by leading consultants, architects, and builders for projects, domestic, industrial and agricultural wiring for trouble free working. These connecting cables are used for submersible pump motors; and are manufactured keeping in mind the severe and difficult conditions in which they are required to perform. The individual conductors are made from bright electrolytic grade copper; and drawn, annealed and bunched properly to ensure flexibility and uniform resistance. Each of the 3 copper conductors is insulated with special PVC compound. The cores are laid up in flat parallel position. The outer sheath of the cable is made from a special grade of abrasion resistance PVC compound imperious to water, grease, oil, etc.



Contact:

Empire Cables Industries Pvt Ltd
115 Phase II, Badli Industrial Area, Delhi 110 042
☎ 011 – 2789 3424, 2386 8832
E-mail: empirecables@yahoo.co.in

Chemical & Oil Guard Gloves

Sawalka Kel Pvt Ltd offers a range of Chemical and Oil Guard Gloves like Oil Grip Gloves NITRICHEM: 18G fine seamless knitted gloves; Double dipped nitrile coated; Palm sandy finish for better grip; and EN388:2016-4121A. Oil Protection Gloves NITR1/FDL/528: 15G Nylon liner with Spandex; Fully coated with nitrile; Palm sandy finish for better gripping; EN388:2016-4132X; Chemical Protection Gloves Cut Levels 5/D NITRICUTS: 13 Gauge Seamless knitted gloves; HPPE Shell and Glass fibre liner; Sandy nitrile on Palm and fingertips; EN388:2016 – 4X43D; Chemical Reusable Gloves; Chemical and Cut Protection Glove – Level E; Disposable Gloves; etc.



Contact:

Sawalka Kel Pvt Ltd
5A, Robinson Street, 3rd Floor, Kolkata 700 017
☎ 033 – 2287 8117 • Mob: 70440 90501
E-mail: gloves@sawalka.net

Rotary Valve

Roto Tech Engineering Systems offers Rotary Valve. The basic use of the Rotary Airlock Feeder is as an airlock transition point, sealing pressurized systems against loss of air or gas while maintaining a flow of material between components with different pressure and suitable for air lock applications ranging from gravity discharge of filters, rotary valves, cyclone dust collectors, and rotary airlock storage devices to precision feeders for dilute phase and continuous dense phase pneumatic convey systems. Rotary Valve Rotary airlock feeders/rotary airlock valves are used in pneumatic conveying systems, dust control equipment, and as volumetric feed-controls. The benefits of Roto Tech Rotary Airlock Valves and Feeders: These Valves are used in a wide range of applications, where there is need to minimize system air loss while transferring material between vessels with differing pressures; They are used as feeder valves to meter the flow of material between vessels with equivalent pressures; Also doing double duty in systems where there is a need to minimize system air or gas loss while regulating the flow of material between vessels with differing pressures.



Contact:

Roto Tech Engineering Systems
D/F 57, Bhagyoday Shopping Center
Nr: Bethak, Naroda, Ahmedabad, Gujarat 382 330
Mob: 90160 75167 / 99781 01936
E-mail: rototechengg@yahoo.com

Digital Pressure Gauges + Transmitter

Arbuda Instruments offers Digital Pressure Gauges + Transmitter. Features: Nominal size: 63 and 100 mm; Accuracy: +0.25% and 0.15% of full scale; Case and Bezel: ABS plastic and aluminium anodized; Wetted parts: SS 304L/DD 316L; Scale range: -1 to 700 kg/cm²; Battery life: 2 years power saving mode/1000 hrs cont. Applications: Generally used for corrosive gases and liquid media and for calibration lab use.



Contact:

Arbuda Instruments
E-11/1 GIDC Sector-26, Gandhinagar, Gujarat 382 027
Mob: 90337 11390 / 93282 97128
Mob: 82649 37896 • E-mail: info@arbudainstruments.com

Visit: www.ips.co.in
to view our e-magazine

LT & HT Panel

Rayline Connectivity is a trusted manufacturer of high-quality LT and HT panels, designed to meet the most demanding electrical requirements. The panels are engineered for reliability, efficiency, and safety, ensuring seamless operation across a wide range of industrial, commercial, and infrastructure applications. LT and HT



panels are built with advanced technology and high-grade materials, offering superior protection for electrical circuits and systems. They are designed to handle high loads, ensuring optimal performance and protection against faults, short circuits, and overloads. With a focus on user-friendly operation, these panels are easy to install and maintain, providing long term value and operational efficiency. Whether you're working with medium or low voltage systems, Rayline's panels are tailored to deliver dependable solutions that meet the highest standards of quality and safety.

Contact:

Rayline Connectivity Pvt Ltd
B-38 Gandhi Colony, Pawanpuri
Bikaner, Rajasthan 334 003
Mob: 75977 76828 •
E-mail: info@raylinepower.com

Split Case Fire Pumpset Horizontal

Lubi Industries LLP offers Horizontal Split Case Fire Pumpset. Performance – Flow Range: 500 to 3000 US gpm; Head Range: 40 to 230 psi. Available with Diesel Engine drive as well as Electric motor drive and Controllers.

Applications: Commercial complexes and high rise buildings, Petrochemical industries and Gas plants, Oil and Gas on-shore and off-shore platforms, Oil terminals Airports and ports, Jetties, Marine applications, Power stations and transformer stations, Chemical industries, Manufacturing plants, Fire work industries, Warehouses/godown, etc. Lubi's products includes: Single-stage End-suction pumps, Single-stage Bare Shaft End-suction pumps, Submerged Centrifugal pumps, End-suction Centrifugal Monoblock pumps, Close-coupled SS Centrifugal pumps, Horizontal Single-stage Centrifugal pumps, Horizontal Multistage End-suction pumps, Vertical Multistage Centrifugal pumps, High-pressure Vertical Multistage Centrifugal pumps, Horizontal Split Case pumps, SS Submersible Bore Well pumps, Drainage pumps, etc.

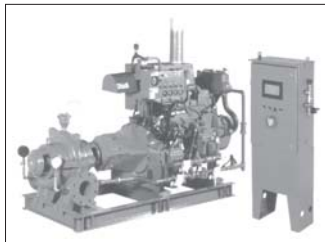

Contact:

Lubi Industries LLP
Near Kalyan Mills, Naroda Road, Ahmedabad, Gujarat 380 025
☎ 079 – 3061 0100 • E-mail: indsales@lubipumps.com

LT/LV Cables

Rajasthan Cables And Conductors Pvt Ltd, an ISO 9001: 2008 Company manufacturers of high quality Cables and Conductors supplies LT/LV Cables. The Cables are two or more wires in a row and bonded, braided or twisted together to form a single congregation, but also submit to a heavy strong rope. For electric industries these serves as the carrier of electric current. The entire range of cables is ideal for power management solutions and power distribution applications and is perfect for refinery, oil and gas processing sites chemical and power generation, fertilizer sites, transportation and urban development applications. The Company's products range includes: Power Cables, Control Cables, Aerial Bunched Cables, House Wiring Cables, etc.



Contact:

Rajasthan Cables And Conductors Pvt Ltd
A-190 C, Road No: 1-D, Vishwakarma Industrial Area (VKIA)
Jaipur, Rajasthan 302 013
☎ 0141 – 400 6002 • Mob: 98290 12103
E-mail: info@rajcables.co.in

Dynamic Sealing Pump

Sintech offers Dynamic Sealing Pump. As the largest Dynamic Sealing Pump supplier in India Sintech deals with the best quality Dynamic Sealing Pumps and offers them to clients. These pumps are in compliance with industrial norms and standards and widely demanded in domestic and international markets. Benefits of Dynamic Sealing Pump: These specially developed pump for juice application use no external Mechanical Sealing arrangement. The dynamic sealing pump is the most economical way to substantially reduce maintenance cost and make the pumps absolutely leak proof. Specifications: Capacity Max.: 1,000 m³/hr; Head Max 140 m; Temperature: 160°C; Working Pressure: 40 kg/cm². The Company's products range includes: Dynamic Sealing Pumps, Torque Flow Pumps, Process Pumps, Vertical Sump Pumps, Split Casing Pumps Double Suction, Split Casing Pumps Single Suction 2 Stage.



Contact:

Sintech Precision Products Limited
C-189 & 190, Buland Shahar Road Industrial Area
Site No: 1, P B No: 92, Ghaziabad, Uttar Pradesh 201 001
☎ 0120 – 417 6000 / 286 6320 • Mob: 93190 83345
E-mail: sales@sintechpumps.com

SS Welded Pipes

Suncity Sheets manufactures brilliantly engineered steel products that are known for their robust built, durability and quality across the world. The Company supplies SS-Welded Pipes in Round, Square, Rectangular, Oval, and Slotted shapes. Round Pipe – Outside dia: 9.52 mm to 127 mm; Wall Thickness: 0.6 mm to 4.00 mm; Length: Up to 12 m; Austenitic Grade: 202/304/316; Specifications: ASTM A554. Square Pipe – Outside dia: 10 x 10 mm to 100 x 100 mm; Wall Thickness: 0.6 mm to 4.00 mm; Length: Up to 12 m; Austenitic Grade: 202/304/316; Specifications:

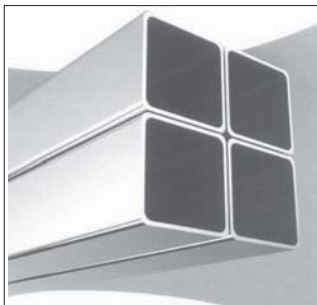

ASTM A554. Rectangular Pipe – Outside dia: 10 x 20 mm to 50 x 100 mm; Wall Thickness: 0.6 mm to 4.00 mm; Length: Up to 12 m; Austenitic Grade: 202/304/316; Specifications: ASTM A554. Applications are in industries like: Automobile and Machinery; Chemical Plants; Dairies and Food Products; Fabricators; Fertilizer Plants; Furniture and Railways; Oil and Gas; Paper and Pulp; Pharmaceuticals; Power Plants; Sugar; and Water Treatment Plants.

Contact:

Suncity Sheets

Plot No: 27-A/66-68, 2nd Floor, Adarsh Society, New ITI Circle Jodhpur, Rajasthan 342 001
☎ 0291 – 274 1103 • Mob: 77370 62301
E-mail: info@suncitysheets.com

Crude Oil Start Up/Dispatch (COD) Pumps

COD Pumps are used to carry crude oil from the well head to gathering and processing facilities and from there to refineries and tanker loading facilities. Also for restart rocking and slop transfer applications at pump stations. Goma is a leading manufacturer of High-Pressure Reciprocating Positive Displacement Plunger/Piston Pumps and Systems.



Contact:

Goma Group of Companies

Plot No: B/66, Road No: 34, Nehru Nagar Wagle Industrial Estate, Thane West 400 604
☎ 022 – 4161 4161 • Mob: 90046 54240
E-mail: pumpdivision@goma.co.in

Solenoid Operated Interlocking Device

Solenoid Interlocking device are unique combination of Castel Lock and Key arrangement to ensure definite sequence of operation of one or more industrial and substation equipment as per customer requirement. Especially used in Dry Transformers, Switchgears, Substation and Industrial Equipments. Features: Each job is engineered by our experienced team to give a unique lock and key combination; Assures series and sequences of appropriate operations; Unique lock and key combinations make it full proof; For any of the models the equipment cannot be utilized even if any one of the keys is missing; Designed ergonomically for easy and smooth operation; Visible lock/unlock condition; Excellent finish; Robust construction for long life; Master key if asked by the supplier along with the supply is provided. Models: Outside Control Key can be locked with several side lock key; Different models having solenoid with NO or NC contact can be made; Combination having different series of operations can be made.



Contact:

Rajshi Engineers

2 BHEL Indl Estate, PO: BHEL, Jhansi, Uttar Pradesh 284 129
☎ 0510 – 277 0090 • Mob: 94151 13335
E-mail: rajshijhs@yahoo.com

SS Hydraulic & Instrumentation Tubes

Venus manufactures and supplies SS Hydraulic and Instrumentation Tubes. Features: Outside Diameter: 6 mm to 76 mm; Wall Thickness Range: 0.50 mm to 8.0 mm; Length:



As per Requirement. Maximum up to 24 Meter long; Grades: 304/L/H/LN, 316/L/H/LN/Ti, 309, 310/L/H/S, 317/L/H, 321/H, 347/H, 405, 409/L, 410, 430/Ti, 436, 439, 1.4301, 1.4306, 1.4571, 1.4541, 1.4401, 1.4404. UNS S31500, UNS S31803, UNS S2205, UNS S32750, UNS S32760. Specifications: ASTM A-213, A-269, A-789, EN 10216-5. Supply Condition: Solution-annealed, pickled and passivated, Bright Annealed. Applications: Nuclear and Thermal Power generation; Oil and Gas; Process Industries; Chemical and Fertilizer; Nuclear Power; Food and Beverage Processing; Automotive; Aerospace; Medical and Pharmaceutical.

Contact:

Venus Pipes and Tubes Limited

Survey No: 233/2, Village Dhaneti, Bhuj-Bhachau Highway Kutch, Gujarat 370 020
Mob: 70488 97799 / 70488 98899 • E-mail: info@venuspipes.com

Roots Vacuum Pumps

Toshniwal Instruments (Madras) offers Roots Vacuum Pumps. The Roots-type pumps belong to the group of positive displacement delivery pumps. Two symmetrical pistons having an eight feature, housed in the pump body, rotate in opposite directions with no contact neither between each other or with the pump body, meshing continuously. The pistons are driven by a set of gears with synchronized rotation, which guarantees friction free movement. During rotation, a progressively growing space is created with corresponds to the suction stage: phase 1 and 2, being gradually decreased phase 3 and 4, compressing the volume of gas. This cycle is repeated four times per each complete rotation of the drive shaft.



Contact:

Toshniwal Instruments (Madras) Pvt Ltd
267 Kilpauk Garden Road, Chennai 600 010
☎ 044 – 2644 8983 • Fax: 044 – 2644 1820
E-mail: sales@toshniwal.net

Pneumatic FFS Machine – Weigh Filler

Sampack India Corporation offers Pneumatic FFS Machine – Weigh Filler. This machine is Auto Weighing, Filling, Sealing, Coding, Batch Cutting, Counting all in one machine. One special feature is that in this machine you can produce the packets ranging from 10 g to 1000 g, and it is suitable for packing Rice, Sugar, Dal, Grains, Granular products, Millet, Whole Grains, Vegetable Seeds, Tea, Alfalfa, Dried Fruits, Nuts, Herbs, Spices and all kinds. Specifications –Max Capacity:

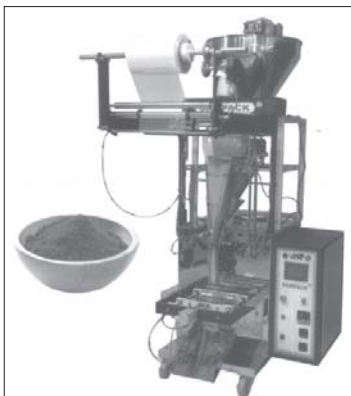

10 g to 1 kg; Filling System: Weigh Metric; Accuracy: +2 g based on products; Packing Speed: 5 to 10 packs per minute; Control Panel: PLC; Contact Parts: SS 304; Electricity Consumption: 4 kW; Power Supply: AC 220 V; Hopper Capacity: 35 kg (for Rice and Dal); and Gross Weight: 380 kg. Sampack India Corporation is a manufacturer and exporter of Automatic Packing Machines, Powder Pressing machines, Chips and Snacks Packing Machines, Granules Packing Machines, Grains and Pulses Packing machines, Liquid Packing Machines, Peanut Bar and Cake Packing Machines, Spices Packing Machine,

Contact:

Sampack India Corporation
No: 16, NGR Street, PN Palayam
Coimbatore, Tamil Nadu 641 037
☎ 0422 – 495 8111 • Mob: 94478 14433
E-mail: cbe@sampackindia.com

Vacuum Nutsch Filter

Uni-Mech Industries supplies Vacuum Nutsch Filter, which is Closed/Open Filtration under Vacuum/atmospheric pressure along effective washing. Nutsche Filter is consisted Cylindrical Shell/Rectangular Shell, Top Open/Dish-end with/without Davit Arm attachment. All Filters are manufactured from Mild Steel, Different grades of Stainless Steel (SS 316/ SS 304), Hastelloy, Mild Steel with Lining or Coating like FRP Lead or Rubber, PTFE, Halar in accordance to the Chemical properties. These Equipments are used in Dyes and Intermediates, Pesticides, Insecticides, Pharmaceuticals and Fo-od industries, where Solid-Liquid Separation by Filtration with Safe Solvent recovery, Preventing Atmosphere from Hazardous Chemicals. Uni-Mech's range of products include: Centrifuges, Filtration and Separation equipments, Heat Exchangers and Distillation Columns, Pressure Vessels, Reactors and Agitators, Storage Tanks, Exotic Metal Process Plant Equipment, Filtration and Separation Equipments, Skid Assemblies, etc.



Contact:

Uni-Mech Industries
Plot No: C-14/15/53, Akshar Industrial Park
Opp: Zydus, Chacharwadi, Ahmedabad, Gujarat 382 213
Mob: 90990 87832 / 90990 87834
E-mail: rld@unimecindia.com

Shear Beam Load Cell & Mounting Assembly

Mokal Corporation offers Shear Beam Load Cell and Mounting Assembly. Features: Capacities star from 300 kg to 10,000 kg; Analog/Digital version, Alloy/Stainless Steel; Accuracy Class C3/C4/C5/C6; Protection Class IP68 and



IP69K. Available in ATEX version (optional). Also offers Bending Beam Load Cell and Mounting Assembly, Single Point Load Cells, Tension Load Cells (S Type), Compression Load Cells, Load Pins; Inductive Proximity Sensors, Capacitive Proximity Sensors, Photo Electric Proximity Sensors, Magnetic Proximity Sensors, Ultrasonic Sensors; Weight Indicators, Controllers, Mounting Accessories, etc.

Contact:

Mokal Corporation
Sai Niwas CHS, Plot No: 54/55
Opp: Chhatrapati Shivaji Maharaj Udyan, Phase II, Sector 22
Kamothe, Panvel, Navi Mumbai, Maharashtra 410 209
Mob: 84519 04444 • E-mail: sales@mokalcorporation.in

Chemical Plants & Process Equipments

Aerolite Engineers, an ISO 9001-2015 certified manufacturer for equipment like Reactors, Heat Exchangers, Condensers, Columns, Evaporators, Tanks, and Vessels. These equipment are used in Chemical, Pharmaceutical, Petrochemicals, Speciality Chemical, Paint and other Process industries. Reactors: CGMP and SS Reactors – Capacity: 1 kl to 40 kl; Design Pressure: Up to 15 kg/cm²g; Temperature: -50°C to 300°C. Tanks and Vessels: CGMP and Stainless Steel Tanks and Vessels – Capacity: 1 kl to 50 kl; Design Pressure: Up to 50 kg/cm²g; Temperature: -50°C to 300°C. Heat Exchangers – Capacity: up to 500 sq mt; Design Pressure: Up to 50 kg/cm²g; Columns - Capacity: Up to 55 m in length; Design Pressure:



Up to 30 kg/cm²g; Temperature: -40°C to 250°C.



Up to 30 kg/cm²g; Temperature: -40°C to 250°C.

Contact:

Aerolite Engineers Pvt Ltd
B-3 Chandralok, Mehta Apt, Punjabi Lane, Off LT Road
Borivli (W), Mumbai 400 092
☎ 022 – 2890 7203 • Mob: 74200 77851

Industrial Valves

Kesharbhawani is a manufacturer of Industrial Valves. The Company manufactures and supplies of different types of valve fittings such as Ball Valves, Butterfly Valves, Safety



Valves, Gate Valves, Globe Valves, Diaphragm Valves, Check Valves, Pulp Valves, and PTFE lined valves, Forged Valves, and many other valves products. These valves are used in industries like Chemicals; Oil and Gas; Food and Beverages; Energy; Pharmaceutical; Pulp and Paper.

Contact:

Kesharbhawani Engineering Private Limited
Shed No: C-51 Ved Industrial Park 1
100 F Kathwada-Bhuvaldi Road, B/h: Shreenath Estate
Kathwada, Ahmedabad, Gujarat 382 430
Mob: 95744 88845 / 90992 74443 • E-mail: info@kbsvalves.com

Disc Springs

International Industrial Springs produces Disc Springs, which are Conical in shape and have a unique combination of high force in small space with customised deflection. Normally Disc Springs are loaded in Axial Direction. IIS Disc Springs offer a well-developed solution to many engineering problems. These Springs can be used as Single or arranged in Stacks. Disc Springs Stack can consist of Disc Springs either used in Series or Parallel Sets. Disc Springs are available with or without contact flats; and are manufactured to DIN 2093/DIN EN16983 Standards and Designed as per DIN 2092/DIN EN 16984 Standards. Group 1 and 2 Disc Springs are Austempered, this method of Heat Treatment is particularly effective for High Fatigue Disc Springs. IIS produces and stocks standard DIN 2093 Disc Springs as well as Imperial (Inch) and Metric (mm) sizes. The Company offers Disc Springs with special sizes and load ratings with widest material options.



Contact:

International Industrial Springs
Plot No: AS/26, Road No: 10, Wagle Industrial Estate
Thane, Maharashtra 400 604
☎ 022 – 6847 0000 / 2582 1941
E-mail: sales@internationalsprings.com

Triple Offset Butterfly Control Valve Series 47000

Enoch manufactures a range of high technology control valves. The triple offset eliminates all rubbing between the seat and seal ring during valve travel, reducing seat and seal wear and extending cycle life.

Once the seat and seal ring are fully engaged, torque is applied in order to create a bi-directional, zero leak, and metal-to-metal seal. Size: 3" to 80"; Pressure Rating: ASME 150# to 900# / 1500# and 2500 #. Features: Tripe Eccentric design; uninterrupted 360° contact; Excellent flow control rangeability; Disc design for minimum dynamic torque; ANSI/FCI 70-2



leakage rate up to Class VI; Metallic/Laminated Graphite/PTFE seal; Modified Equal percentage Inherent flow characteristic; NACE MR0175 compliance; and Low maintenance. Applications: Slurry, Paper and Pulp industries; Chemical Fertilizers, and Water Treatment and Gas Plants.

Contact:

Enoch Controls Pvt Ltd
Plot No: A-40, Near Garware, MIDC, Ambad
Nashik, Maharashtra 422 010
☎ 0253 – 238 3548 • Mob: 96375 88673
E-mail: sales@enochvalve.com

Vacuum Pumps and Systems for Power Plants

Kakati Karshak Industries Private Limited, manufacturers of Liquid Ring Vacuum Pumps and Systems offers a range of Vacuum Pumps and Systems for Power Plants. Kakati KTC Series (*pix top, left*) Liquid Ring Vacuum Pumps are two stage Vacuum Pumps, which are created for high vacuum applications. The integral two stage impeller design allows it to condense process vapors and to recover or dispose of them. Some of its main applications include condenser evacuation system and black liquor evaporation. The KVT Series (*Pix, bottom right*) are used primarily in evaporation and turbine condenser vacuum applications. Owing to its very sturdy and unique design these pumps can be run for very long periods between overhauls. KDS Series (*Pix, bottom left*) are created for high vacuum applications. As the name suggests they have two stages integrated in one pump. They are designed to operate in low suction pressures while offering peak efficiency. Common applications include Turbine condenser evacuation, black liquor evaporation, vacuum distillations, vapour recovery systems, etc. The 2KE1 Series Plate Type Single Stage Vacuum Pumps (*Pix, top right*) are primarily used in Turbine condenser applications of large power plants. Coupled with an air ejector, these vacuum pumps offer excellent protection for damage against cavitation.

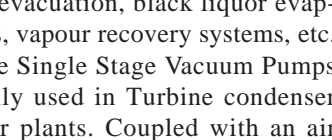
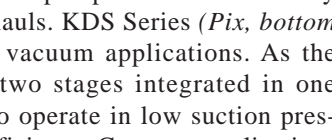
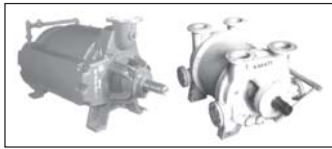

Contact:

Kakati Karshak Industries Private Limited
Plot No: P-4/1, Road No: 1, Nacharam Industrial Area
Hyderabad, Telangana 500 076
☎ 040 – 2715 3104 / 2715 3105
E-mail: marketing@kakatipumps.com

Industrial Valves

UNP Polyvalves is a leading manufacturer of various types of corrosion free valves, pipes and pipe fittings produced in advanced engineering plastics. The range includes: ball valves, butterfly valves, ball check valves, foot valves, sight glass, sampling, strainers, lined valves, etc. These valves are made out of polypropylene, HHS isotactic PP, PVDF, ETFE (Tefzel); UPVC, CPVC. Fluoropolymer lined piping system made out of PTFE, PVDF, FEP, PFA, ETFE, ECTFE, etc.

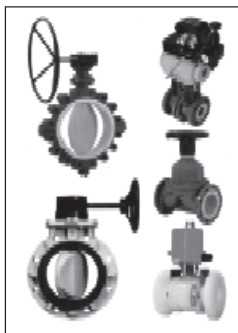

Contact:

UNP Polyvalves (India) Pvt Ltd
207 Orion Business Park, Next to Cine Max, Kapurbawdi
Ghodbunder Road, Thane (W) 400 607
☎ 022 – 2589 6422 • E-mail: mktg@polyvalve.com

Pressure Reducing Valve

Lehry make Direct Activated Pressure Reducing valve with inbuilt strainer internal balancing line SDT Semi Pilot Diaphragm Operated Screwed/Flanged for Water Line with Inbuilt Strainer. Functions: Pressure reducing valves are installed in residential water systems to reduce and stabilize inlet pressure from the water mains supply, which is generally too high and variable for domestic appliances to function properly. These valves can also be used to control inlet pressure to domestic hot water storage. Features: Pressure adjusting range: 1-5 bar; Max inlet pressure: 16 bar; Ambient temperature: up to 85°C; Connection: Screwed End (BSP); Media: Water, Gas, Air and Oil. Lehry's products range includes: Lead free Brass Ball valves, Forged Brass Ball valves, Extended Stem Brass Ball valves, Butterfly Valves, Brass Y-Type Strainer, T-Type Strainer, Brass Check Valve, Air Release Valve CI/Brass, etc.



Contact:

Lehry Instrumentation & Valves Pvt Ltd
Lehry Chambers, New No: 78 (Old No: 51), Sembudoss Street
PB No: 1506, Parrys, Chennai 600 001
☎ 044 – 2522 6995 / 2522 6187 • E-mail: info@lehry.com

Centrifugal Chemical Process Pumps

Jay Ambe manufactures and supplies Centrifugal Chemical Process Pumps, and Centrifugal Chemical Process Pumps (Closed Type). Products range also comprises Polypropylene Chemical Process Pumps, Industrial Valves, etc. JEC Centrifugal Chemical Pumps cover a range of capacities extending to 700 m.cu/hr at 1450 rpm, and 300 m.cu/hr at 2900 rpm. Head range up to 145 metres. Design pressures to 25 bars and process temperatures extend from -40°C to +300°C, depending on the material of construction. Materials: All parts that come into contact with the liquid are made from Cast iron, Ductile iron, Rubber Lined, Cast steel, Bronze, Ni-Resist, Ni-Cast iron, Stainless steel, Alloy-20, R.52, R.53, R.55, Hastelloy-C, Hastelloy-B and other Alloy grades as per operating conditions. Applications: Acid Transfer, Beverage Processing, Brine, Chemical Processing, Chlor-alkali, Corrosive-Services, Organic Chemicals, Polymers, Sea Water, Solvents, Paper, Food, Synthetic Fibers, and Slurry.



Contact:

Jay Ambe Engineering Co.
New Survey No. 416 & 1464, Near Kuha Water Canal Kothiyakuha Road, Ahmedabad, Gujarat 382 433
Mob: 99786 28298 / 80486 04994
E-mail: sales@jecwoodland.com

Vertical Pumps

Alpha Techno-Chem supplies a wide range of Chemical Process Pumps and Equipments. The Vertical Pumps offered are efficient and dependable for Acids, Caustic, Plat-



ing Solution, Effluent Treatment, Waste Water Treatment, etc. Features: Flow up to 18 m³/hr; Head up to 20 m; SS cantilever shaft protected by heavy walled Polypropylene Sleeve; Heavy duty cast iron motor support with ball bearing separations pump shaft and motor shaft; and Rugged glass filled

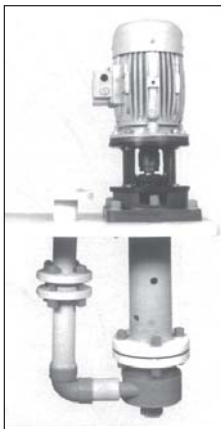

poly-propylene Impeller for long life. The Company's products range are: Air Operated Double Diaphragm Pumps, Polypropylene Centrifugal pumps, Metallic pumps, Metering and Dosing pumps, PVDF Liner Centrifugal pumps, Screw pumps, Teflon Lined Pumps; etc.

Contact:

Alpha Techno-Chem Equipments & Services
Unit No: 2, Gr Floor, Jai Estate, Plot No: 6, 6A, 6B
Opp: State Bank, Phase-1, MIDC, Dombivli East
Dist: Thane, Maharashtra 421 204
Mob: 84228 84458 • E-mail: info@alphatechnochem.com

FRP Underground Storage Tank

EPP offers an FRP Underground Storage Tank. Its Key Features: Single Wall/Double Wall Secondary Containment Construction; Petroleum and Explosive Safety Organization (PESO) Certified; Designed with integral Ribs for increase in Strength and Robustness; Easy to ship and easy to install; Rust-proof; Good Physical and Mechanical Strength; Light Weight; Excellent Corrosion Resistant; Fuel Compatibility; UL 1316; Environmentally Safe; Durable with Long Service Life; Weather-proof; Low Maintenance. MOC: FRP-Unsaturated Polyester Resin (UL Listed) with ECR glass. Manufacturing Process: Shell Filament Winding; Dish End: Hand Layup. Applicable Standards: BSEN B121-3:2016; PESO Approval. Uses: Gasoline; Diesel Fuel; Motor Oil; Methanol Blends; Oxygenated Motor Fuels; Jet Fuel; Ethanol Blends; Kerosene.



Contact:

EPP Composites Pvt Ltd
Plot No: 2646, Kranti Gate, Main Road
GIDC Metoda, Rajkot, Gujarat 360 021
Mob: 90990 72505 • E-mail: businessdevelopment@epp.co.in

Pump for Corrosive & Abrasive Fluid Services

Alfa Pumps (P) Limited offers Dryrun-proof TNP Series vertical cantilever pumps, which are the solution of choice whenever it comes to pumping solids-laden acids, alkalis or chemically contaminated effluents or when there is a risk of prolonged dry running. Features: Vertical centrifugal pump with volute casing and single-entry, single-stage radial impeller; without bottom bearings; the shaft bearing is located outside the path of the fluid pumped. Impeller is positively locked to the shaft for reverse rotation protection; Circular or rectangular sole plate; special sole plate geometries and sole plates with supporting flange available on request. Duty Conditions – Capacity (Q): Up to 200 m³/hr; Head (H): Up to 60 m; Opt temperature: -30 to 125°C; Opt. pressure (p): up to 6 bar; Discharge size: DN 25 to DN 65. User-friendly design, no measurement, no adjustment, no special tools and no special skill required for installation and maintenance.



Contact:

Alfa Pumps (P) Limited
58-59 Shreenathji Estate, Bakrol (Bujrang), Daskroi
Ahmedabad, Gujarat 382 430
Mob: 95120 26134 / 951 20 26129
E-mail: contact@alfapump.com

Traction Alternator C1009TA

CG offers a wide range of Traction Alternators. CG manufactures a wide range of traction alternators both - Static and Brushless, for all Diesel Locomotives. Traction Alternator Type C1009TA is designed for 700 HP Diesel Electric Tower Car and Self-Propelled Inspection Car (SPIC). High Voltage: 345 Amps, 666 Volts, 230 kW at 1800 RPM; Low Voltage: 718 Amps, 320 Volts, 230 kW at 1800 RPM; Insulation: Class H; Ventilation: Self-ventilated; Coupling Type: Flex Plate Coupling; Weights: 150 kg (approx.) Suitable for underslung mounting (beneath the bogie). Features: Provision for rectifier mounting on its top; Brush less excitation for alternator field; Compact rotating diode wheel design; Alternator field and exciter on a same shaft; Self locating single ball bearing at non driving end.



Contact:

CG Power and Industrial Solutions Ltd
CG House, 6th Floor, Dr Annie Besant Road
Worli, Mumbai 400 030
☎ 022 – 2423 7700 • E-mail: help@cglobal.com

Oil Free Rotary Vane Vacuum Pumps

Shree Siddhivinayak Industries, an ISO 9001-2015 Certified Company offers Oil Free Rotary Vane Vacuum Pumps. These pumps do not contain any sealing lubricating fluids that come in direct contact to the vacuum in the pumping chamber. These pumps are completely dry and required no internal lubrication, low noise and reliability make these pumps an ideal choice for many OEM applications. Minivac make RVD Series vacuum pumps offer ideal solution for a wide range of applications from paper handling and electronics to environmental technology. Self-lubricating specially designed graphite vanes ensure oil free operation with high level of reliability. These offers all three functions vacuum, compressed air or the combination of both in one compact unit. These rotary vane pumps are environmental friendly, highly efficient, vibration free and extremely reliable. Maintenance is easy and can be carried out at operator end. Application industries: Graphite/Printing: Rotary Printing/Sheet fed Offset/Screen printing/Book binding/Folding Plate Making Equipment. Pharma: Capsule Filling/Printing and other pharmaceutical machines. Packaging: Blister packing/Labeling machines.



Contact:

Shree Siddhivinayak Industries
Plot No: 19, Kashimira Industrial Estate
Off Western Exp Highway, Mira, Dist: Thane
Maharashtra 401 104
☎ 022 – 2845 8372 / 2845 7073
E-mail: response@minivacpumps.com

Stainless Steel High Pressure Pneumatic Solenoid Valve

Aira Euro Automation Pvt Ltd is a leading manufacturer of Stainless Steel High Pressure Pneumatic Solenoid Valve, SS Y-type Strainer, Solenoid Valve Screwed End, Extended Shaft Ball Valve, Aira Float Valve and Steam Safety Valve Pop type Flanged. Product Details: Valve Size: 1/4" to 2"; Media: Air, Water, Oil, Gas; Material: CF8 / CF8M / CF3M; Voltage: 12, 24, 110, 230 AC / DC; Operating Pressure: 2 to 12 kg; Power: AC/DC; SS Grade: CF8 / CF8M / CF3M; Model: HPSE; Seals: Viton / PTFE / EPDM. Packaging Type: Plastic Polythene Bag / Corrugated Box.



Contact:

Aira Euro Automation Private Limited
123-124, Aira Estate, B/h Security Estate
NR Kashiram Textile Mill, Narol
Ahmedabad, Gujarat 382 405
Mob: 80486 08929 • E-mail: airaeuro86@gmail.com

NOP Filter Pumps

Nippon Oil Pump India offers NOP Filter Pumps. Features of YTH-EP: An All-in-one, High-to-medium Pressure coolant Unit; All components of a coolant system are consolidated into a single expands the available plant space, resulting in a higher production efficiency; Maximum operating pressure: 7.0 MPa; No suction filter is required; No inline filter is required; No plumbing is required to interconnect various components. Turbulence™ Filter. Special Turbulence™ design generates turbulence around the surface of filter with 2 wing-shaped vanes rotating around filter and can wash away sludge from filter surface continuously. Nippon Oil Pump India Private Limited is Indian subsidiary of Nippon Oil Pump Co., Ltd., Japan, engaged in manufacturing of liquid transportation products like Filter Pumps, Trochoid Oil Pumps and Hydraulic Index Motors etc. NOP Filter Pumps are innovative products combining pump and cyclone filter built into single unit, with either high pressure piston pump, medium pressure trochoid pump or impeller pump used for machine tool coolant emulsion and cutting oil. NOP India brings the world-class technology of Nippon Oil Pumps to India supported by local manufacturing and comprehensive customer support. NOP India provides a wide range of liquid transportation products for a wide spectrum of applications, serving a multitude of industries ranging from machine tools, engineering and automotive industry, oil chillers, industrial burners, non-conventional energy and hydraulics industries etc. NOP makes hydraulic motors used in machine tools for indexing applications, agriculture and farm equipment, etc.



Contact:

Nippon Oil Pump India Private Limited
Building # 3, Plot No: 175-176, 11th Main, 3rd Phase
Industrial Area, Peenya, Bengaluru, Karnataka 560 058
☎ 080 – 4123 8431 • E-mail: info@nopindia.com

HD RH Series Hidamp RH Series

HD RH Series Hidamp RH Series mounts are suited for effective isolation of noise and vibration in diesel engines, Generator, A/C units, General machinery, Amusement park equipments, construction and farm equipments, compressors, etc.

Contact:

HiDamp Industrial Mountings Pvt Limited
Hidamp Gardens, Vedapatti, Coimbatore, Tamil Nadu 641 007
☎ 0422 – 653 2118 • Mob: 75981 53078 / 94897 53070
E-mail: hidamp@hotmail.com

Sight Flow Indicator

R K Dutt offers a wide range of Sight Flow Indicators. Features are: with larger view area, drip lip - standard for all metallic body; Indicator: flapper or rotary for invisible liquids or gases; Sizes: wide range from 15 NB to 250 NB; Choice of glass: Indian - Sodium Silicate for 50°C to 120°C; Imported - Borosilicate DIN 7080 std for -50°C to 300°C; Choice of material: SS, CS, A105, A182 F, semi-welded, seamless, PP, PTFE. RK Dutt manufacturing liquid level indicating, measuring and controlling instruments since 1974.



Contact:

R K Dutt Concerns

Plot A, 88, Road No: 18, Neheru Nagar, Wagle Industrial Estate
Thane West, Maharashtra 400 604
☎ 022 - 6724 8787 2582 2541
E-mail: marketing@rkduitt.com

EOT Crane

Eddycranes Engineers, manufactures Elmech make EOT cranes conforming to Class I, II, III and Class IV (M1 to M8), heavy duty application as per IS: 807-2006, IS: 3177-1999, IS: 4137-1967 wherever applicable. EOT cranes are manufactured from 0.5 ton to 150 tons capacity in single Girder design as well as in double Girder design. Elmech EOT cranes offer technologically advanced features such as box type girders for torsional rigidity and strength, tapered plate design for joining the girders to the end carriage to ensure smooth flow of stresses, duly hardened forged wheels running on spherical roller bearings in L-type housing, geared couplings, high torque, crane duty, gearboxes, etc. These cranes offer long life and minimum noise during its operation; and are supplied with safety features consisting of brakes in all motions, limit switch in all motions, overload relays and single phase preventer for all motors in control panel, etc, also with pendant push button controller for operation from floor, or master controllers for operation from driver's cabin or with radio remote control arrangement. Eddycranes Engineers also manufactures Elmech Hoists, Grabbing Cranes, Goliath Cranes, HOT Cranes, Flameproof EOT Cranes and Electric Hoists and Winches etc.



Contact:

Eddycranes Engineers Pvt Ltd

3/23 Tardeo A/C Market, Tardeo Road, Mumbai 400 034
☎ 2352 2710 / 2352 5103 / 2352 1798
E-mail: eddycranes@vsnl.com

Screw Conveyors

Screw Conveyor is among the simplest and most versatile type of Material Handling Equipment. MASYC offers - Standard Pitch, Short Pitch, Variable Pitch, Double Flight, Tapered Flight and Ribbon Flight Screw Conveyors to suit various applications. The Screw Flights are formed on the hydraulic press so as to maintain accurately the screw dia, pitch and the helix angle. Single Shaft, Double Shaft Paddle Conveyor mixers are also available. Screw conveyors handling highly abrasive material can be designed without hanger bearings up to the length of 12 m. MASYC, an ISO 9001: 2000 Company has a formidable presence in the market in Bulk Material Handling Systems and Equipments. The Company has more than 30 years of experience in turn-key execution of Bulk Material Handling Systems. Their products range of various conveying systems and equipment suit and match all the requirements in different processing industries like Cement, Steel, Coal, Pulp and Paper, Glass, Fertilizers, Mining, Power, etc.



Contact:

MASYC Projects Pvt Ltd

23 Community Center, Mayapuri Phase-I, New Delhi 110 064
☎ 011 - 2811 5745, 2811 5453 • Fax: 011 - 2811 6850
E-mail: masyc@masycproject.com

Globe 3 Way Control Valves (Series 130)

Pneucon offers Globe 3 Way Control Valves (Series 130). Its features: High Flow capacity and rangeability; Heavy Duty top guide with additional skirt guiding on the plug; Heavy duty ground and polished stem; Wide range of interchangeable trim sizes; Bellow seals available for positive stem sealing; Comprehensively designed and tested to ensure its optimum performance for 5th toughest process parameters specified; Wide selection of actuators to meet most system requirements; All testing performed to the requirements of ASME 16.34. Specifications-Design: ASME B16.34; Body Form: Globe type with Tail piece to provide third port; Valve size: 15 to 300 mm (1/4" to 12"); Rating: 150 to 1500 ANSI; Trim Form: Linear, V-Port Skirt Guided; Flow Chart: Linear, On/Off; Seat Leakage: IV, V and VI (FCI-70.2); Actuator: Diaphragm, Piston or Electrical; Actuator Action: Direct/Reverse Acting.



Contact:

Pneucon Valves Pvt Ltd

Plot A-35, Road # 10, Wagle Est, Thane, Maharashtra 400 604
☎ 022 - 2583 8371 • E-mail: info@pneuconvalves.com

Chemical Process Pump PCPS Series

Chemical process pump is an important device for handling of hazardous chemicals in industries. Whether conveyance or use in chemical reactions, chemical products need to be handled efficiently and with care in order to avoid any kind of damage or corrosion occurring at the working place. Chemical process pumps of PPI Pumps Pvt Ltd are the absolute solutions for handling of corrosive or hazardous chemicals in pharmaceutical, chemical and process industries. Available in 1 m³/hr to 100 m³/hr capacities, these are high performance ISO pumps and are compatible for work with different kinds of corrosive liquids. These pumps are available with different kinds of sealing solutions including single mechanical seal for non-corrosive to moderate corrosive liquids; double mechanical seal to handle low flows of abrasive chemicals; bellows seal for handling highly corrosive liquids at extreme temperatures; and cartridge seal for ease of maintenance while handling moderate corrosive liquids. High performance with minimum maintenance and less energy consumption is what PPI chemical process pumps are designed to provide for a much longer period of time for efficiency in industrial processes.



Contact:

PPI Pumps Pvt Ltd

14&16-C, Phase-I, GIDC Estate, Vatva

Ahmedabad, Gujarat 382 445

☎ 079 – 2583 2274 /3251 6741

Mob: 99040 67775 • E-mail: sales@ppipumps.com

Hydraulic & Pneumatic Products

Savantec Automation (P) Ltd supplies Hydraulic and Pneumatic Products. Their products range includes Air Gun, Air Silencers, Camlock Couplers, Solenoid Valves, Check Valves Fittings, Clamping Cylinders, Clean Fittings, Compact Fittings, Flow Control Valves, Hand Valves, High Pressure Nozzles, HP Couplers, KCC Pneumatic and Hydraulic Cylinders, KOBA Industrial Shock Absorbers, ROTOFLUX Rotary Unions, Sang A PU Fittings and PU Hoses and Couplers, etc.

Contact:

Savantec Automation (P) Ltd

No: 3&4, First Floor, Shop No: 6, Mogappair Road

Mannurpet, Padi, Chennai 600 050

☎ 044 – 4856 8963 • Mob: 73583 12666

E-mail: sales@savantecap.com

Visit: www.ips.co.in
to view our e-magazine

Sucking Blower

Shama Global Pvt Ltd offers Sucking Blower. Features: this high vacuum blower comprises a dynamically balanced impeller, which revolves around a stator-cum-compression chamber having very fine clearances between them; the impellers are fitted directly on the motor shaft to reduce impedance to the air flow both the suction and pressure openings are located on the outer periphery of the stator thereby creating vacuum and pressure; there is no wear and tear no lubrication requirement as the impeller rotates with no contact between itself and the casing; these heating systems are manufactured in compliance with Indian boiler regulations for thermal engineering and thus, assure less fuel consumption and rated capacity. The company is involved in manufacturing and supplying various types of industrial type Heating equipment. The product range includes steam boilers, Coil Type Steam Boilers, Shell and Tube Steam Boilers, Oil and Gas Fired Steam Boilers, IBR Shell and Tube Boilers, Hot Water Generator and thermic fluid heaters.

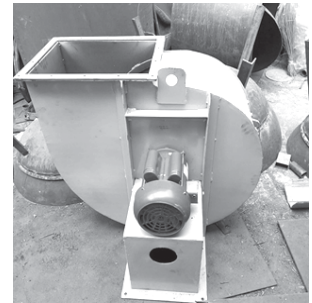

Contact:

Shama Global Pvt Ltd

Bhakri Industrial Area, Plot No: 9, Nawada Village

Sector 49, Faridabad, Haryana 121 004

Mob: 99990 22825 • E-mail: shamaglobal786@gmail.com

Steam Jacketed Kettle

Nav Durga Boiler offers Steam Jacketed Kettle. The features are: the product, steam-jacketed kettle is very large, deep kettles mounted on a pedestal or legs to stand on the floor; there is a sealed area between the outside wall and the jacket into which steam is pumped, which does even heating and cooking of the food in the kettle. Steam though, never touches the food; there is a faucet at the bottom to allow liquid to come out of its spout. Some steam-jacketed kettles can also be tilted and have stirrer mounted vertically with a gearbox and motor; the company provides kettles with capacities as per customer needs and are known for superior finish and excellent quality.



Contact:

Nav Durga Boiler And Equipments Pvt Ltd

Shop No. 3, New, St Stand Road, Ganeshpeth Colony

Nagpur, Maharashtra 440 018

☎ 0712 – 272 1005 • Mob: 94221 11525

E-mail: navdurgaboiler@yahoo.in

Acrylic Body Manometers

Fitzer Instruments offers solid acrylic body U-tube, inclined and single limb type manometers, which are accurate and dependable as well as highly versatile for many applica-

tions. Scales are graduated to correct for the drop in the well level for inclined and single limb manometer for high accuracy. General specifications – Body: fabricated in 25/32 mm thick

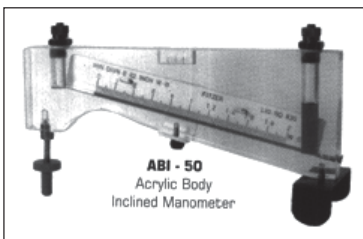

acrylic plastic solid block virtually unbreakable stable and free from distortion; Scale graduation: plastic milky white printed scale; Manometric fluid: red gauge oil, specific gravity 0.823; End connection: 1/4" BSP (F) or PVC nozzle type; Packing: Neoprene/PTFE; Mounting: wall panel and flush mounting holes; Accessories: Plastic box contains liquid storage bottle and liquid filling funnel arrangement – zero adjusting knob, level bulb; Accuracy: $\pm 0.25\%$, $\pm 0.1\%$ of FSD or better; Test pressure: 1.5 time of operating pressure; and Temperature: below 70°C.

Contact:

Fitzer Instruments Company (India)
Atali, Near Ambivali Station (W), PO: Mohone
Tal: Kalyan, Dist: Thane, Maharashtra 421 102
Mob: 86918 16354 / 86918 16355 / 86918 16356
E-mail: fitzergujarat@rediffmail.com

Pipe Conveyors

MASYC Projects Pvt Ltd offers Pipe Conveyors. It has all the advantage over a typical conventional Belt Conveyor while adding further characteristics of having Horizontal



and Vertical curves. It can also have steep angles without any transfer points. It can convey dust as well as bigger lump sizes; and is particularly recommended in Cement Industries, Power, Fertilizer, Steel and Glass Plants etc. The Company also offers Pulse Jet Bag Filters, Impact Hammer Crushers, Heavy Duty Bucket Elevators, etc.

Contact:

MASYC Projects Pvt Ltd
23 Community Center, Mayapuri Phase-I
New Delhi 110 064
☎ 011 – 2811 5745, 2811 5453, 2811 3383
E-mail: masyc@masycproject.com

Rotary Triple Twin Gear Pump Type NDX Series

Del Pd Pumps & Gears Private Limited supplies Rotary Triple Twin Gear Pump Type NDX. NDX Series pumps are designed to handle bulk volume of viscous and semi viscous liquids quite efficiently at medium pressure up to 11 bar. This pump can be coupled directly with drive as impeller speed reduction is made possible within pump, making it very compact and cost economical and thereby



reducing the overall cost, and space. The timing gear reduces the noise level and enhances the working life of the pump. This pump out performance twin Screw pump in all aspect in this range and they are suitable for wagon decanting, cargo-unloading of various viscous liquids such as edible oils, Fuel oils, viscous chemicals, etc. Step-down Versions are also available. Type MDX comes without reduction gears whereas Type JDJ comes without timing and reduction gears and Type JDB is with bush bearing suitable for molasses applications. Size: from 5" to 12" NB (Flanged to ASA 150 Class); Capacity from: 80 m³/hr to 550 m³/hr; Pressure: up to 11 kg/cm², Viscosity is up to 1,00,000 CST, and Temperature up to 110°C.

Contact:

Del Pd Pumps & Gears Private Limited
Plot No: 113, GIDC Estate, Wadhwan City
Surendranagar, Gujarat 363 035
☎ 02752 – 243 047/243 464/243 678
Mob: 99988 17576 • E-mail: info@delpump.com

Files

PFERD offers a wide range of Files, which are useful for manual roughing, finishing, chamfering and sharpening tasks. PFERD offers an extensive range of files and rasps, holders, handles and devices ideal for coarse to delicate work on a variety of materials. The company is engaged in the development, production and support, as well as in the distribution, of tool solutions for work on surfaces and material cutting. It operates as an independent, internationally oriented, family-owned company geared towards offering the user maximum benefit and optimum cost-effectiveness.



Contact:

PFERD
467 B-Block, AECS Layout, Kundalahalli
Bangaluru, Karnataka 560 037
☎ 080 – 4218 7117 • Mob: 98806 65415, 97414 81117
E-mail: sales@swt.in

Turbine Inlet Valve

Baroda Flowtech Private Limited offers Turbine Inlet Valve. The inlet valve in a hydro power station is used as a safety device. The valve is located within the power house on the upstream side. The inlet valve is used for isolating the Hydro-turbine for maintenance purpose also. The inlet valve is basically a Butterfly valve having a very less head loss. The hydraulic power pack is mounted on the driving end of the valves. The non-driving end of the valve trunion is mounted with a dead weight arrangement through a lever. For small & medium turbines where grid power is not available, the valve is opened by a hand pump provided in the power pack. For Large power plants where grid power is available valve is opened with the motorized operation of the power pack. The inlet valve is provided with a by pass arrangement from the upstream side to the downstream sided, a valve provided in the bypass arrangement is opened so that the pressure in the both side of the valve is in equilibrium condition. After this the valve is opened.

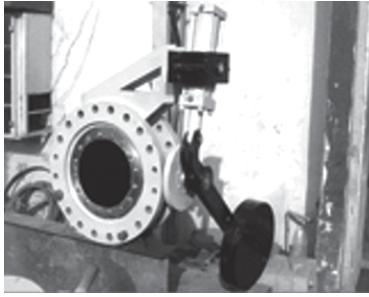

Contact:

Baroda Flowtech Private Limited
28-B, Puneet Nagar, New Sama Road, EME Post Office
Vadodara, Gujarat 390 008
☎ 0265 – 2711 141 • E-mail: deepak@barodaflowtech.com

Hydraulic Products

Deepak Ind Hydraulics manufactures a wide range of hydraulic products such as Hydraulic Cylinders, Hydraulic Power Packs, Gear Pumps, Vane Pumps, and Plunger

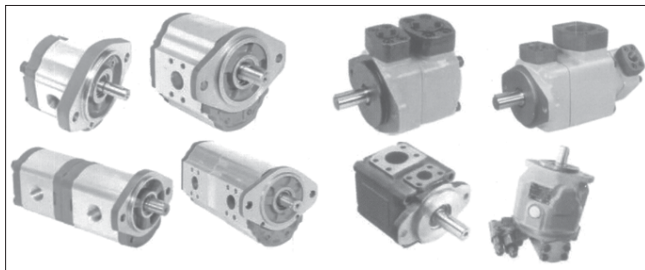

Pumps, Hand Pumps, Mobile Valves, Solenoid Valves, Hydro Motor, Steering Units, Prefill Valve, PCM & Pressure Relief Valve, Counter Balance Valve, Hydraulic Hoses and Connectors, Bell Housing, Pressure Gage, Manifolds, Accessories, Honed Tubes and Plotted Rods, Seals, Coolers, Seamless Tube and MSC, etc.

Contact:

Deepak Ind Hydraulics
1st Kasthuribai Street, Ganapathy
Coimbatore, Tamil Nadu 641 006
Mob: 75400 75756 / 75400 75775
E-mail: marketing@deepakind.com

Thermal Relief Valve

V Tech Valves And Controls offers Thermal Relief Valve. The features are: standard design: the thermal relief valve series, VT-100 safety valves has 316 stainless steel, investment casting flanged end as standard design and material; Material Selection: Verity of materials are offered as per the current needs of an industry. Design Option: All Thermal relief valve Valves have an option of O ring seat seal for tight shut-off and st-ellited trims for high pressure and temperature. Reliable Performance: Proven design ensures safe and reliable performance. Easy Maintenance: High Performance and easy maintenance procedures are the characteristic of this valve. The company manufacturers of industrial valves under the V-MAK Brand. V Tech Valves and Controls ISO 9001-2015 Certified Company is fast growing company as a leading manufacturer of all type of Industrial valves.

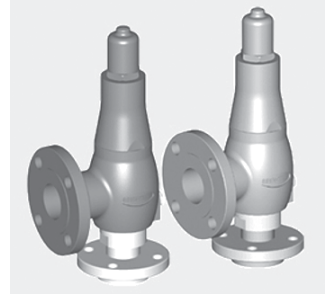

Contact:

V Tech Valves And Controls
7-13, Karm Industrial Park, Near Krishna Industrial Park
Kathwada GIDC, Odhav Industrial Estate
Ahmedabad, Gujarat 382 430
Mob: 98984 69586 • E-mail: info@vtechvalvescontrols.com

Butterfly Valve

Nirmala Pumps & Equipments offers a wide range of Butterfly Valve. The features are: butterfly valve design is an essential aspect which controls the flow of fluid through a piping system; it has a quick opening and closing quarter-turn function that controls the flow of gases or liquids. Butterfly valve typically pivots on an axis perpendicular to the direction of flow inside the flow chamber and is situated on a spindle that allows for flow in a single direction; this valve is frequently used as a throttling device which controls the level of flow in entirely closed/opened or partially opened positions; and they offer butterfly valves in various materials such as PVC, aluminum, stainless steel, ductile iron, carbon steel etc. The company established in 1989, is acclaimed for the manufacturing and supplying broad spectrum of Pump and Valve.

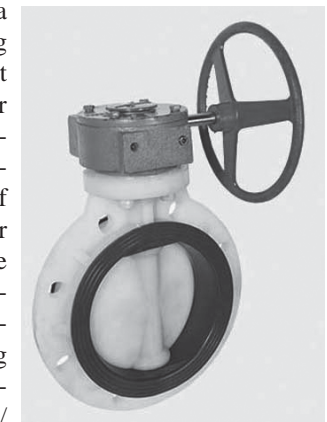

Contact:

Nirmala Pumps & Equipments
Shed No. 74-75, Gangotri Estate, Near Vatva Ramol Cir
Phase IV, Ahmedabad, Gujarat 382 445
Mob: 84012 62518 • E-mail: sales@nirmalapumps.com

Butterfly Valve

Coimbatore Flow Controls Private Limited offers Butterfly Valve. The features are: top flange drilled to suit ISO 5211; bolt circle dimensions to suit all standard Like DIN, ANSI, API, BS 10 Table D&E etc.

Unique centre stem lock design virtually eliminates any disc movement while during the open / close function; unique stem retention system to blow out proof stem easy assembly and disassembly of valve body - heavy duty single piece in fabricated and two piece in castings double flanged body designed to withstand specified pressures and ratings; disc - investment / fabricated high strength disc with polished disc edges and hubs ensures excellent corrosion resistant to several chemical media. The company established in 1988, have more than 24 years valve manufacture experience. These valves are manufactured in various material of construction to suit specific service conditions, and temperatures. These valves are used to control the flow media and are used in chemical, fertilizers, sugars, paper, pulp and oil industries.



Contact:

Coimbatore Flow Controls Private Limited
A-7 K, L.R. Building, 207, Sastri Road, Ramnagar
Coimbatore, Tamil Nadu 641 009
☎ 0422 – 2232 435 • E-mail: coflow@rediffmail.com

Lined Globe Control Valve

Protrol Valves offers a superior quality assortment of Teflon Lined Globe Control Valve Manufacturer in Mumbai. The Teflon Lined Globe Control Valve provided by us is basically designed to control the pressure of chemicals such as hydrochloric, sulfuric, nitric acids and many more. Available in different specifications and other customize options, we manufacture this Teflon Lined Globe Control Valve by making use of the superior quality raw materials and is coated with Teflon Lined Globe Control Valve to prevent from corrosion effect. The product range of Teflon Lined Globe Control Valve Manufacturer goes through a series of quality tests in order to ensure its flawlessness prior dispatch. Their organization deals in offering an extensive range of this Teflon Globe Control Valve, which can also be customized as per the specification give by clients. These are manufactured utilizing best grade crude materials and acknowledged for the durability, inherent flow characteristics, high-density PTFE body, and leak-proof features.

Contact:

Protrol Valves
A-11, Jaimatadi Compound, Behind Ramdeo Hotel
Kalher, Bhiwandi, Thane, Maharashtra 421 302
Mob: 93243 72771 • E-mail: protrol51@yahoo.co.in

Stainless Steel and Cast Iron Pumps

Investa Pumps Pvt Ltd offers Stainless Steel and Cast Iron Pumps. The features are: these pumps are manufactured with stainless steel and cast iron or cast steel castings for various duties in chemical plants; the cast iron/ steel pumps are used in water pumping in utility sectors of chemical plants. Stainless steel pumps are supplied to various solvent handling applications or other chemical handling applications pertaining to different industry; all these above pumps have high wall thickness to take maximum pressure rating upto 20 bar. All the above CI/SS parts are casts in different induction furnaces only to maintain the exact quality of chemical compositions; and investa can produce highly efficient SS/CI pumps thus enabling the growth of any chemical plant. The company established in 1997 and has been consistently producing investment cast stainless steel, cast steel and other super alloy pumps having a wide range of models. The company manufactures centrifugal and centripetal pumps in horizontal and vertical construction.



Contact:

Investa Pumps Pvt Ltd
Unit No. 5, Hind Service Industrial Estate
Shivaji Park, Dadar West, Mumbai 400 028
☎ 022 – 2446 0630/31, 2447 4434
E-mail: office@investapumps.co.in

Process Pumps EO/EOS Series

Egger Pumps offers Process Pumps EO/EOS. Its Features: Pumping of fluids with gas contents up to 25%; Semi-open impeller; Different numbers of blades. Facts and figures – Nominal dimensions: DN 50-500 mm; Flow rate: up to 1500 l/s; Differential Head: Up to 150 m; Pressure: Up to 30 bars; Temperature: Up to 180°C. Applications: Demanding fluids in the chemical and petrochemical industries; Multiphase mixtures for reactor loops; Aerated fibre suspensions in the pulp and paper industry; Wastewater and viscous materials in wastewater technology; Sledges; Numerous abrasive and corrosive fluids.



Contact:

Egger Pumps India Pvt Ltd
SF No: 206, Kannampalayam (PO), Suler (Via)
Coimbatore, Tamil Nadu 641 402
☎ 0422 – 268 9855 •
E-mail: info.india@eggerpumps.com

Pipe, Tubes, Fittings & Flanges

Unnati Group, an ISO 9001: 2015 Certified Co is one of the manufacturers of Pipes, Tubes, Fittings and Flanges in different MOC like Stainless Teel, Carbon Steel, and Alloy



Steel, Nickel Alloys, Copper and Brass Alloys products. Products range: Pipe – Size: 15 NB to 1200 NB in SCH 10 to SCH XXS; Type: Seamless/Welded/Fabricated/LSAW Pipes; Form: Round, Square, Rectangular, Hydraulic, etc. Tubs – OD: 32 mm to 203.2 mm; Thickness: 0.1 mm to 4.75 mm; Length: Up to 28 m. Fittings and Flanges – Size: ½”



NB - 48" NB; SCH: 5 to SCH XXS. Application industries: Automobile, Oil and Gas, Paper and Pulp, Sugar, and Textile; Cement Plants, Power Plants and Chemical and Pharmaceutical.

Contact:

Unnati Group

Gr Floor, Shop No: 2. A-Wing, 1/207 and 208 Fugio Tower
130 Sukalaji Street, Kamathipura, Mumbai 400 008
Mob: 98694 21930 / 97370 44831 / 96647 14476
E-mail: info@lumsalloys.com

Forged Steel Valves

Component Engineering offers Forged Steel Valves. The features are: this valves are compact in size and with forged steel bodies. They are available in OS & Y type, bolted bonnet rising stem with renewable seat rings; the valves are checked with spring loaded disc for better performance; and these valves are designed for both screwed and socket weld ends as per design standards. The company a professionally managed, valve and valve components manufacturing company specialized in ball valves and manual valve actuators catering to the engineering, process and petroleum industries in flow control activities.



Contact:

Component Engineering

B67, MIDC Ambad, Nashik, Maharashtra 422 010
☎ 0253 – 2380 160 • E-mail: sales@componentengineering.in

ORION Dry Vacuum Pump

Kumark Vacuum Systems Pvt Ltd was established in the year 2000. It started working with ORION Machinery, Japan in the year 2010 as their distributor for Industrial Dry Vacuum Pumps in India and has been offering its various products to meet industrial needs. Kumark Vacuum Systems has a very well-proven and highly rich

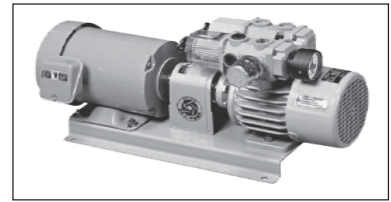

experience of 15 years in the industry. It has been putting its efforts to continue to serve high-quality dry vacuum pumps with a diverse range of capacities. The Company offers ORION KRX Series Dry Vacuum Pumps. Features: No oil in either vacuum, blower or combination application; Quiet operation; Long life; Gauge and controller equipment standard; and Dependable and proven design. Flow Rate: 135 – 1190 L/min. Capacity: Design displacement, logic value is calculated from the cubic volume. The actual flow rate refers to the actual measurement data of performances; It is not allowable to use it at the maximum vacuum reaching point of the pump; Usable range of the degree of vacuum/blower pressure; For the intake air, use clean air of normal temperature and normal humidity whenever possible; Intake air condition: Temperature 0 to 40! and Humidity 65% RH ±20%; The allowable variation range of the supply voltage should be ±10% of rated voltage; Install an overload protector (thermal relays, etc.)

Contact:

Kumark Vacuum Systems Pvt Ltd

TC 32/1727, Sreesailam, Madathuvilakam, PO: Peroorkada
Thiruvananthapuram, Kerala 695 005
☎ 0471 – 243 4798 • Mob: 93878 91774
E-mail: info@inpresvac.com

Pressure Reducing Valve

Green Manufacturing Co Limited manufactures Pressure Reducing Valve. Features: Test Pressure: 1.6 Mpa; Working Temp from 0°C to 80°C; Screwed Female Ends as per BSP; No External Strainer required as NEU-G PRV has in-built strainers; Working medium: Water. The Company's products range include: Forged Brass Air Release Valve, Butterfly Valve, Multi-Utility Check Valve, Wafer Type Check Valve, Swing Check Valve, Dual Plate Check Valve, etc.



Contact:

Green Manufacturing Co Limited

C-20, Canal Road, Industrial Area, Jalandhar, Punjab 144 004
☎ 0181 – 506 3236 • Mob: 98881 23236
E-mail: newpipefittings@gmail.com

Horizontal Pumps

Plastico Pumps offers. The features are: temp. up to 120°C; suitable with V-belt drive or direct coupled with a motor; a heavy duty shaft, sturdy construction, simple design, back pull out design; micro metric wears adjustable facility hence, works at constant head for a longer period; non-clogging and handles solids up to 10 mm, The company manufacturers of Horizontal Pumps. These are horizontal pumps: end suction, horizontal, centrifugal coupled pumps with semi open impeller. JCP pumps are centrifugal semi open impeller type pumps smaller volume using less floor space. Horizontal Pumps Operating Range: Capacity : up to 40 m³ /hr, Head : up to 48 hrs, Size : 25 mm to 65 mm, Temperature : 80°C, Speed : up to 3500 rpm, Pressure : up to 5 Kg/cm, M.O.C : C.I, C.S., SS-304/304L SS 316/316 L, Bronze, Alloy-20, CD4MCU, Hast alloy B & C, etc.

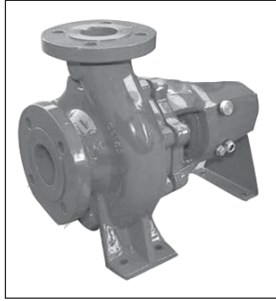

Contact:

Plastico Pumps

199/2 GIDC Estate, B/h: Bank of Baroda

Nadesari, Vadodara, Gujarat 390 010

☎ 0265 – 2840 787 • Mob: 98250 69165 / 94287 64521

E-mail: plasticopumps@gmail.com

Single Step Pickling Passivation Product for SS and its Alloys

Surface Innovators LLP launches a new Technology Virtually Fume Free. A Single Step Pickling Passivation Product for SS and its Alloys. Revolutionary Red Colour and is ASTM A-967 Approved. Available in Gel Form Brush Application; Semi-Gel Form Spray Application; and Dip Liquid Application. Single Step Process for Pickling and Passivation; Reduction in fumes to negligible level; Red in colour helping easy identification post application; Improves Corrosion Resistance; Provides smoother and whiter surface; No change in grain structure of the base material; Improves Process Efficiency; Improves Human Safety and reduces Risk; Quality Improvement; Improves Product Life; Better Homogeneity; Improves Visual Inspection. K-2 range of products are suitable for all kinds of fabricated Stainless Steel Vessels, Equipments, Silos, Reactors, Mixer Vessels, Heat Exchangers catering to Pharma, Chemicals, Food and Beverage, Petrochemical and Desalination Plant. Chemicals, Protective Gears, Cleaning Devices, Effluent Neutralizers, First Aid Kits, Supervisor and Inspection Services, Spray Equipments, Jet Cleaning Machine, Ventilated Protective Suit, Neutralizing Waste Disposal Chemicals, etc.

Contact:

Surface Innovators LLP

G-2, Creative Industrial Estate, Next to HP Petrol Pump

N M Joshi Marg, Lower Parel (East), Mumbai 400 011

☎ 022 – 2309 7759 / 2300 5205

E-mail: anish@surfaceinnovators.com

High Vacuum System

Vindi Vak Pump Pvt Ltd offers High Vacuum System. The features are: the operating vacuum of around 710 mm hg is considered low now-a-days, due to the recent development in the manufacturing process; it has become essential to create more vacuum in the process system to save the energy, in the distillation process or to have a better yield; watering vacuum pumps has its own limitation to develop vacuum at a higher range. To achieve more vacuum in process, they recommend use of high vacuum system. It is also known as two stage vacuum pumping system; these systems are capable to create 1 mm hg absolute pressure with bank suction. To enable us to design your specific high vacuum systems, they would like to know the capacity of pump (in M³/hrs or in CFM) at operating vacuum. The material of construction of the systems depends upon the medium being handled. To enable us to select proper material, they would like to know the medium to be handled by high vacuum systems. The company with a state-of-art workshop facility acquired in One Acre Industrial Land in heart of Ahmedabad city having ISO: 9001:2015 certified, they introduces as one of the leading manufacturer and exporter of Vacuum Pumps, Roots Type Blowers, Metering and Dosing Pumps in India.



Contact:

Vindi Vak Pump Pvt Ltd

Plot No: 1905/1906, CIPET, GIDC, Phase IV

Vatva GIDC, Ahmedabad, Gujarat 382 445

☎ 079 – 2589 3659 • Mob: 82470 04222

E-mail: info@vindivak.com

Pneumatic Products

Shree Prayag manufactures a range of Pneumatic Actuators, Fittings, Tubings and other Pneumatic Accessories, Pneumatic Cylinders, Pneumatic One Touch Fittings, Solenoid Valves, Mechanical Valves, Foot Pedal Valves, Push/Pull Hand Draw Valves, Process Control Valves, etc.

Contact:

Shree Prayag Air Controls (P) Ltd

A-56 & A-33, Sector-57, Noida, Uttar Pradesh 201 301

☎ 0120 – 473 3333 • Mob: 95827 95598

E-mail: sales@spacpneumatic

May 2025 : ACMEE 2025 Exhibition +
Focus: Machine Tools & Automobile
Accessories

Automation X20 Drives

B&R Industrial Automation offers Automation X20 Drive. It is designed for automating machine components like conveyors and adjustment axes. Automation X20 Drives offer a wide range of motion possibilities in a compact design; perfect for controlling motors from a few watts up to 1 kW, this drive provides a cost and energy-efficient solution for your automation needs. With its well-thought-out details and a sophisticated ergonomic design, X20 Drives with 48 V low voltage technology, enable control of stepper and brushless DC motors up to 1 kW in the familiar form factor of X20 slice based I/O family; the new drive series brings increased scalability and flexibility in a compact design, with the ability to control two motor axes in a width of only 27.5 mm. A variety of encoder options, including encoderless operation, cater to diverse application needs. The company is a manufacturer of automation technology and ABB's global center for machine and factory automation.

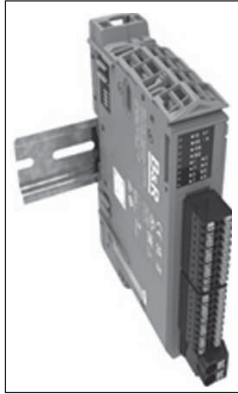

Contact:

B & R Industrial Automation
8 Tara Heights, Old Mumbai-Pune Highway
Wakadewadi, Pune, Maharashtra 411 003
☎ 020 – 4147 8999
E-mail: marketing.in@br-automation.com

Pressure Booster Pumps, SCM Series

Shakti Pumps offers Pressure Booster Pumps SCM Series. Features: Compact design; Worldwide usage; High reliability; Easy to service and install; Silent operation; Wide performance range; Full stainless steel design; Booster sets for domestic water supply; Automatic start/stop when equipped with pressure control or pressure tank. Performance: Head – Max 125 m; Flow – 6 m³/hr; Discharge: Max 100 LPM; and Rating: 0.5 HP to 5 HP. Applications: Suitable for liquid transfer; Small industrial water supply systems; Washing systems; HVAC; Water treatment systems; Fire fighting systems; Industrial plants; Boiler feed systems; Pressure boosting systems; Domestic Water supply; and Horticultural irrigation.



Contact:

Shakti Pumps (I) Ltd
Sector-3, Pithampur, Dist: Dhar
Madhya Pradesh 454 774
☎ 07292 – 410500 • E-mail: info@shaktipumps.com

Visit: www.ips.co.in
to view our e-magazine

Impact Sockets

Reliable Trade Links offer Impact Sockets. The features are: impact sockets are designed for use with powered impact wrenches or drivers. Impact wrenches can be powered pneumatically, electrically or hydraulically; The combination of an impact wrench and impact socket can deliver greater torque to the head of a fastener than can be achieved with a manual wrench; its features include: can be used with both impact and powered turning tools as well as manual ones; less chance of injury from socket shattering. The company established in 1999. They are a team of quality professionals in the field of engineering, sourcing and commercial activities.

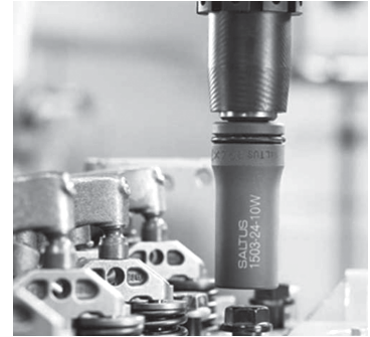

Contact:

Reliable Trade Links
MIG 94, 10th Cross Street, Nolambur Phase I
West Mogappair, Chennai, Tamil Nadu 600 037
☎ 044 – 2654 7920 • Mob: 93810 45752
E-mail: teamreliable@rediffmail.com

Submersible Sewage Pump

Jagdish Textile & Engg offers Submersible Sewage Pump. The features are: this range adopts a high-efficient 4P motor that has been tested by serious quality control and applied high-class insulation to provide long-term operation; a motor installed with an over-load protector to prevent the motor from overheating and overloading; the installation of a high-quality SIC seal to produce high wear resistance and leak-proof motors; speed of flow is superiorly designed and can be applied within large pump housings and impellers to achieve high efficiency and high performance for any wastewater; inner cable wires and cable base are upgraded by filling EPOXY to raise humidity resistance; drainage of the food market; wastewater treatment of animal husbandry, water refining tank waste water plant; drainage of the building basement, waste water treatment of the food industry; pulp and paper industry; steel mill; and other industries, etc. The company is a manufacturer, importer, and exporter of supreme grade high pressure pumps, car washer pumps, etc.



Contact:

Jagdish Textile & Engg Co
Ramoliya Bulding, Opp: Ashok Niwas, Kadia Kui
Relief Road, Ahmedabad, Gujarat 380 001
Mob: 98983 20500 • E-mail: info@jtecump.com

Seamless SS Pipes & Tubes

Blumet Tubes Private Limited supplies Seamless Stainless Steel Pipes and Tubes, which are Annealed and Pickled; Bright Annealed; and Electro Polished. Features: Outside Diameter: 6.0 mm to 152.4 mm; Wall Thickness: 0.7 mm to 6.00 mm; Grades: TP 304/L/H, TP 310/L/H/S, TP 310 MoLN TP 316/L/H/Ti, TP 317/L, TP 321 / H, TP 347/H, 904L UNS SS1500, 31803, 32205, 32750, 32760. Specifications: ASTM, ASME, DIN EN (German), NF (AFNOR), JIS (Japan). Applications:



Heat Exchangers Chemical and Petrochemical Gas Industry, Nuclear Power Generation, Pressure Vessels, Marine Equipments, Food Processing, Automotive, Aerospace. Also offers Nickel Alloy Tubes and U Tubes (Pix, bottom)

that are Annealed and Pickled; Bright Annealed; and Electro Polished. Features: Outside Diameter: 6.0 mm to 101.6 mm; Wall Thickness: 0.7 mm to 6.00 mm; Grades: TP 304/L/H, TP 310/L/H/S, TP 310 MoLN TP 316/L/H/Ti, TP 317/L, TP 321/H, TP 347/H, 904L UNS S1500, 31803, 32205, 32750, 32760. Specifications: ASTM, ASME, DIN EN (German), NF (AFNOR), JIS (Japan). Applications: Oil and Gas Extraction Chemical and Petrochemical, Nuclear Power, Food and Beverage Processing, Automotive, and Aerospace.

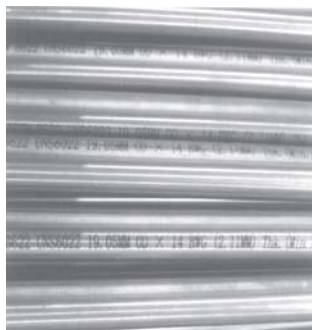

Contact:

Blumet Tubes Private Limited
Omkar Tower 203/204, 2nd Floor, 3rd Khetwadi Back Road
Mumbai 400 004
☎ 022 – 6636 3338 / 6636 3344
E-mail: info@blumetubes.com

Flow Switches

Arbuda offers Flow Switches. The paddle type flow controllers are specifically designed for use on liquid lines such as water, ethylene or any other fluid which is not harmful to brass or phosphor bronze and which is not classified as a hazardous fluid. Features – MOC: Brass/Phosphor Bronze/SS; Max Operating Pressure: 10 bar/140 psi; Media temperature: 1 to 100°C; and Flow rate: M3.



Contact:

Arbuda Instruments
E-11/1 GIDC, Sector 26, Gandhinagar, Gujarat 382 026
Telefax: 079 – 2328 7990
Mob: 90337 11390 • E-mail: arbudainst@yahoo.com

Submersible Sewage Pumps

MBH Pumps (Gujarat) Pvt Ltd offers Submersible Sewage Pumps, which operate directly in the liquid being pumped that means they require neither special housing nor a superstructure to support them, considerably reducing construction costs.

They are smaller than non-submersible counterparts as the motor and hydraulics are integrated into one compact unit, resulting in smaller pumping stations that are less complex to build. Operating submerged they take-up less space, noise and cooling problems are virtually eliminated. The Company has



a wide variety of submersible sewage pumps for various applications. The NS Series and PST Series pumps are perfect solution for domestic and municipal use where as their Contractor pumps and Ni-hard series slurry pumps can handle the most abrasive slurries from infrastructure to power industries. Features: Robust; Powerful; Durable; Environmentally friendly – the cooling system is designed to use its surroundings to cool the pump, no use of environmentally hazardous fluids such as oils. Safe and straightforward – Cable entry prevents both cable strain and leakage. Consistent – the double mechanical seal provides extra reliability and protects against leakage. Flexibility – Drilled pump housing, ready for any installation method. Applications: Municipal sewage pumping stations and sewage treatment plants; Wastewater pumping, and Storm-water pumping stations; Industrial effluents pumping, and effluent treatment plants; Slurry handling for power and steel industry; etc.

Contact:

MBH Pumps (Gujarat) Pvt Ltd
Plot No: 14, GIDC Indl Estate, Naroda
Ahmedabad, Gujarat 382 330
☎ 079 – 2282 3066, 2282 1018
E-mail: marketing@mbhpumps.com

Air Driven Liquid Pumps

Sealing Tech Inc offers Air Driven Liquid Pumps, which are suitable for different flow rates as well as for different operating pressures. Media – water, oil and gas. Max Operating pressures up to 7000 bar (101,000 psi). Applications: Lifting and Clamping, Hydraulic applications, B8urst and Cycle fatigue testing, Leak testing, Pressurization.

Contact:

Sealing Tech Inc
17 St Thomas St, Santhosh Nagar
Kandanchavadi, Chennai 600 096
☎ 044 – 2496 1336 • Mob: 72000 73285
E-mail: mail@sealingtech.in

Process Equipment

John Galt International manufactures and supplies a range of Process Equipment such as Storage Tanks and Bullets, Pressure Vessels and Reactors, Heat Exchangers, Distillation Columns, and Boilers. Products Range – Storage Tanks, which are made of aluminium, stainless steel and carbon steel. Shell and Tube Type Heat Exchangers: Material of Construction – Austenitic Stainless Steel (All 300



SS - 316L Heat Exchanger

Series); Carbon Steel, Hastelloy; Monel; Cu-Ni Alloys; Duplex; Alloy Steel; Inconel; Nickel 200; Titanium; Super Duplex. Specifications – Shell diameter: Up to 5000 mm; Shell thickness: Up to 40 mm; Overall Length: Up to 40 m; Tube Sheet Thickness: Up to 1 m; Max Pressure: 300 bar; Heat Transfer Area: 1 m – 3000 m²; Maximum weight: Up to 300 MT. Aluminium Storage Tanks – 75 kl, and 200 kl; and High Pressure Autoclave Systems. The Autoclave Systems are used to impregnate copper with graphite. End application is for creating contact points with high voltage lines on railway pantographs.

Contact:

John Galt International

Plot B-21/F-2, MIDC Industrial Estate

Badlapur, Dist: Thane, Maharashtra 421 503

☎ 0251 – 269 0120 / 269 1420 • Mob: 98203 25285

E-mail: abhay.bhatic@johngalt.in

Ball Valve, 3-Piece Flanged End

Rasaii Flow Lines offers Ball Valve, 3-Piece Flanged End. Features: Full bore and reduced bore (CI/DI/WCB/CF8/CF8M/CN7M/CF3/CF3M/Hastelloy B&C/CZ100). Design Standard: BS 5351/EN ISO 17292/ASME B16.34; Pressure Class 125, 150 and 300; Size: 15 mm to 150 mm – 3-piece design; Body: ASTM A 351 Gr CF8/CF8M; Trim: AISI 304/304L/316/316L; Seat: PTFE/Peek; Rating: ASME Class 150/300; Face to Face: ASME B16.10; End: ASME B16.5; Testing Std.: BS 6755-1/API 598; Optional: Fire Safe – API 607; Mounting Pad – ISO 5211. User areas: Refineries, Petrochemical, Fertilizers, Sugar, Paper industry, Steel, Cement, Pharma, Waste Water, Food, and Power Plants, etc.



Contact:

Rasaii Flow Lines Pvt Ltd

Ferndale, 1st Avenue, RWD Palm Layout

Nr: Gayathri Nagar, Medavakkam, Chennai 600 100

Mob: 93848 00896 / 93848 00897

E-mail: admin@rflvalves.com

Ball Valves

Global Valves And Fittings (India) Private Limited, an ISO 9001:2015 Certified Company supplies Ball Valves. Features – Maximum Working Pressure up to 10000 psi (689 bar); Working Temperature: Up to 212°F (100°C) with Delrin packing up to 464°F (240°C) with PTFE packing up to 842°F (450°C) with PEEK packing; Available in SS304 L/SS316 L, Monel, Hastelloy, Inconel and Duplex. Size: ¼ ~ 2" pipe thread, 35 mm OD and 1/8" OD; Leak tight performances testing for every valve with nitrogen/air at the maximum working



pressure; 100% factory tested; Pane Mountable (optional); Low Operating Torque; Floating ball design for positive sealing; Material Traceability; Compact design; Single piece design and three piece design; 2-way, 3-way and 5-way. Global's products range are: Precision Pipe Fittings, Tube Fittings, Needle valves and Gauge Root valves, Manifold valves, Monoflange valves, Check valves, Relief valves, Pressure regulators, Swivel Fittings, 37° Flare Fittings, Hose Fittings, Condensate Pots, Air Headers, Thermowells, Pressure Gauge Accessories, Tubes, etc.

Contact:

Global Valves And Fittings (India) Private Limited

B/9 (A/34), KJB Compound, Opp: Nahar Amrit Shakti

Khairani Road, Saki Naka, Mumbai 400 072

Mob: 99309 39595 • E-mail: info@globalvalvesfittings.com

Hydraulic Products

Fluidics offers a range of Hydraulic products like Hydraulic Power Units, Hydraulic Trainer Kit for Colleges and Training Institutes. The products range includes: Proportional valve, Servo Valves, Logic Valves, Directional Controls, Flow Controls, Gear Pumps, Vane Pumps, ASR, and ASE Pumps, Tie-Road Type medium, pressure pumps, Welded Type Cylinders, Custom built cylinders, etc.

Contact:

Fluidics Engineers Pvt Ltd

12/1 Vetri Vinayagar Nagar, Sivananthapuram,

Saravanampatti (PO), Coimbatore, Tamil Nadu 641 035

Mob: 98867 71752 / 98431 52346

E-mail: fluides@fluidsmith.com

Springs & Wire-formed Products

Wire Snap Pvt Ltd is a manufacturer of springs and wire-formed products for over 25 years, and the Company specializes in producing high-quality Split Cotter Pin (Under

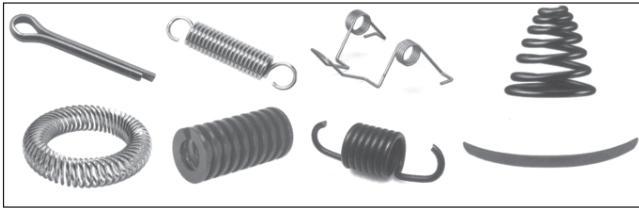

Brand name Surya Pin), all types of springs, Wire Forms, Press Parts and Special Alloy Wires and Bars. Size range from Dia 0.1 mm - 50 mm. The range offered are: Tension

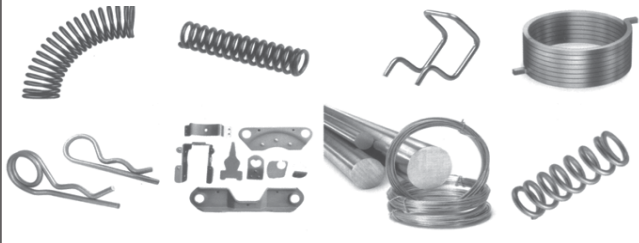

Spring, Conical Spring, Garter Spring, Compression Spring, Die Spring, Clutch Spring, Conical Spring, Clutch Spring, Leaf Spring, Curved Spring, Compression Spring, Shape Wire Spring, Inconel X750, 718 Springs, MP 35N Springs,



Elgiloy Springs, Nimonic 90 Springs, Hastelloy Springs, Duratherm 600 Springs, CuSn8 and CuBe2 Springs, Duplex Wire and Bars, Nichrome Wire and Bars, R-Pin, etc.

Contact:

Wire Snap Pvt Ltd

Gat No: 767, Off Spine Road, We Da Savarkar Road

Near Surya Park, Kudalwadi Chekhali

Pune, Maharashtra 411 062

Mob: 94223 01829 / 91464 24444

E-mail: info@wiresnap.in

Lining Products

Anticorrosion India Pvt Ltd offers Lining Products such as Pipe and Fittings, Strainers – Basket/Y/T; Bellows, Compensators, Butterfly Valves; Dip Pipe, Spargers, Dip Tubes, etc.

Contact:

Anticorrosion India Pvt Ltd

Plot No: E-100, Ranjangaon MIDC, Village Karegaon

Tal: Shirur, Dist: Pune, Maharashtra 412 220

Mob: 98204 29054 / 98239 57462

E-mail: sales@anticorrosion.in

Butterfly Valves

Maruti Industries offers Butterfly Valves with Electropneumatic Positioner, Butterfly Valve with Pneumatic Actuator, Lever Operated Butterfly Valve, and Gear Operated Butterfly Valve. Technical Data – Manufacturing Standard: ISO 5752/BS5155/API 609/IS 13095; Inspection



and Testing Std: BS 6755 (Part-1)/API 598/EN 12266-1; End Connection: Wafer to suit ANSI B16.5 150#/ANSI 125#; BS to Tab D&E/IS 6392 NP 0.6/1.0/1.6; Face to face: BS 5155/ISO 5752/API 609; Top Flange Drilling: ISO 5211. The Company's products range includes: IC Knife Edge Gate Valve, Knife Edge Gate Valve with Pneumatic Operating, and Manual operating.



Contact:

Maruti Industries

119 Vikas Est, Nr: Municipal School, Anil Starch Mill Road

Bapunagar, Ahmedabad, Gujarat 380 024

Mob: 99044 66842 / 98983 74361

E-mail: marutivalves@yahoo.com

Electric Actuated Butterfly Valve

Trisha Engineers offers Electric Actuated Butterfly Valve. The features are: this plastic actuator body passes impaction and acid-base tests and also meets SGS. Valve position can be adjusted from 15 degrees to 90 degrees. The assembly of actuators and valves meets the EN ISO 5211 standard. Improved PP disc to enhance the performance. Thickened body and seal to extend the service life. Materials meet drinking water standards; the material has been modified by nanometers to improve the pressure resistance and impact resistance. Raw materials add anti ultraviolet absorbent and antioxidants, improving durability and aging resistance. The company is a leading supplier of quality sinking thermoplastic products, including PVC / PP / CPVC valves, pipes, and fittings. They cater to various industries like water treatment, metal finishing, chemicals, swimming pools, and spas.

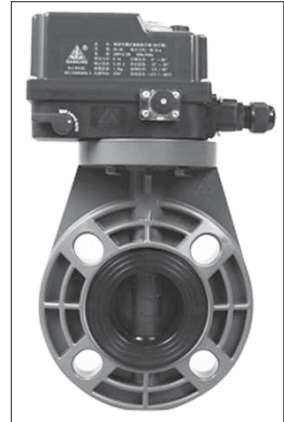

Contact:

Trisha Engineers

#11, Sri Nivasam, Bull Temple A Cross, Behind Uma Theatre

6th Main, Chamarajpet, Bengaluru, Karnataka 560 018

☎ 080 – 2661 4315 • Mob: 93412 70830

E-mail: trishaengineers@yahoo.com

Centrifugal Monoblock Pump

Toshio Technology Pvt Ltd offers Centrifugal Monoblock Pump. Its Features: Axial inlet and radial outlet; Single stage monoblock design; Dynamically balanced Rotor and Impeller; Pumps available with 2880 and 1450 rpm; Good quality Bearing. Technical Data – Flow Range: Up to 135 m³/min; Maximum Head: Up to 76 m; Liquid Temperature: Up to 40°C; Frequency: 50 Hz; MOC:



Cast Iron, SS304 and 316. Applications: Chillers, Gardening and Nurseries, Domestic Water Supply, High rise Buildings, Hotels and Hospitals, Agriculture, Irrigation, Drip and Sprinkler Systems. The Company is an STP/ETP Pumps and Aerator Specialist, and its products range includes: Submersible Vortex Sewage Pump in Different Series, Submersible Grinder Pump, Effluent Pumps, Drainage Pumps, Dredging Pumps, Submersible Mixer, etc.

Contact:

Toshio Technology Pvt Ltd
Unit 1, 601/D, Wifi Park, Road No: 1, Above Satkar Grande
Opp: Aplab Co, Wagle Indl Estate, MIDC
Thane, Maharashtra 400 604
☎ 022 – 2582 8400 • Mob: 91672 02692
E-mail: sales@toshiotechnology.com

Diaphragm Seated SS Metal Body Valves

Sude Engineering Corporation offers Diaphragm Seated SS Metal Body Valves with Plastic Piston Actuator. Type 1168 Series Valves are external Air Pilot Operated Valves, which are used in Pharmaceutical and Food Industries. Operating Diaphragm, isolate body and actuator from incoming fluid. The under mentioned valve and body configurations are available: Spigot to suit welding with ISO seamless pipe; Tri-clamp (TC) end connection. Specifications – Temperature: -10°C to 140°C (EPDM, PTFE/EPDM diaphragm); Ambient Temperature: -10°C to 50°C; Body Material: ASTM A351 CF3M (SS316L); End Connections: Available in Spigot (6) Tri-clamp (7); Diaphragm: EPDM Std, Optional: EPDM/PTFE, BN, Silicon; Finish: Body: Inside RA (um) 0.4, Outside RA (um) 0.8 Electro polished (Optional).



Contact:

Sude Engineering Corporation
No: 1106, 10th Main Road, RPC Layout
Nr: RPC Layout Bus Stand, Hampinagar, Bengaluru
Karnataka 560 104
☎ 080 – 2330 2145 • Mob: 98450 18216
E-mail: sudeengg@gmail.com

Unique Aluminum Labels for Pharmaceutical Plants

Strokes India offers METALPRO™ Unique Aluminum Labels for Pharmaceutical Plants. Pharmaceutical companies, similar to other process industries, require distinct signage specifications for various departments, including housekeeping, production, packing, stores, engineering, lab, QA/QC/R&D, administration, safety and security, and others; METALPRO™ labels, developed recently by the



Company, offers pharmaceutical companies a cost-saving opportunity when used for interior and exterior signage instead of printed vinyl or similar materials; this product provides a unique advantage compared to conventional alternatives: it can be used as a reusable writing surface, just like a blackboard or chalkboard; this versatility makes it suitable for various applications across different departments, such as Mobile Phase, AHU Code, Calibration Status, Dissolution Tester, Volumetric Solution, Equipment Clean Status, Room Status, DOP Testing, Equipment Code, Batch Code, Quarantine label, etc.; the exceptional combination of durability, high-resolution graphic printing in color, and variable data functionality sets METALPRO™ labels apart from other graphic identification materials; this product has several key characteristics: it has a 3M adhesive that allows it to be securely attached to smooth, solid surfaces that are free of grease; it can be printed in individual pieces; it supports multi-coloured printing; it can be written on and rewritten; and it is long-lasting in most industrial settings, both for the printed content and the aluminium sheet itself; as a result, it will greatly help all industry professionals in pharmaceutical formulation manufacturing, bulk drugs, and laboratories if this labeling method is implemented in their organizations; this practice will motivate employees, keep production steady, guarantee safety for all, enhance productivity, and lower expenses related to workplace accidents, ultimately leading to better performance and increased profits. The company is a strategic design, in-depth print and signage solution provider to convey adept business identity of associations.

Contact:

Strokes India
691/A/2, No: 9, 2nd Floor, Bibvewadi Industrial Estate
Pune-Satara Road, Pune, Maharashtra 411 037
Mob: 98220 65602 • E-mail: sales.strokesindia@gmail.com

Subscribe to
Industrial Products Source
at ₹300/- for 1 year.

Fundacart PP Pleated Cartridges

Polypropylene pleated filter cartridges have been designed as an effective membrane prefilter and as final polishing filters for many liquid processing applications. The cartridges are double layered filters. The graded porosity design removes particles in sequence such as larger particles by the more open outer layers and the smaller particles by the tighter inner layers. The outer layer acts as the prefilter while the inner layers provide the rating at the specified pore size. This efficiently spreads the contaminants throughout the media matrix resulting in superior contaminant holding capacity, lifetime and pressure drop as compared to other media cartridges. Features and Benefits: Very good for pre filtration and Clarification of fluids; Graded porosity polypropylene media; 100% PP construction, wide chemical compatibility; Consistent and good flow rates; Biologically safe; No fiber migration; FDA approved; Thermally welded construction; End connections to fit all standard housings.



Contact:

DrM Filter Technology Pvt Ltd
501 The Park Old Padra Road, Near Akshar Chowk
Vadodara, Gujarat 393 020
Mob: 86710 49229 / 96012 95251
E-mail: sauvik@fundabac.com

Porosil - Revolutionary Fusion Process

Purvi Products offers Porosil - Revolutionary Fusion Process. Porosil is a novel welding machine for porosity sealing and surface restoration without heat affected zone (HAZ). Features: It fills cavities, scratches, undercuts and other imperfections in alloys of steel and cast iron; useful for casting defects repairing, it eliminates the need for costly annealing, welding and rehardening procedures on base metal items. Portable unit means repairs can be done directly on the job, without removing the part; Porosil machine is useful for salvaging precision rolls, dies, piston rods, etc. It fills imperfection prior to plating and grinding. The company is a manufacturer and supplier of metal marking machines, portable plating machines, metal etching machines, etc.



Contact:

Purvi Products
30 Alok Bungalows, Near Surdhara Circle
Sal Hospital Road, Thaltej, Ahmedabad, Gujarat 380 054
Mob: 98256 28705 • E-mail: pathik00@gmail.com

Transformer Oil Pumps

Ajay Engineers offers Transformer Oil Pumps. This Centrifugal monoblock (pump and motor have been combined to form a single unit) type pump fitted with single stage closed impeller in volute casing having axial end suction and vertical centerline delivery. Compact in design, can be arranged for horizontal or vertical mounting, totally enclosed and having no glands. The company manufacture, supplier and exporter of centrifugal pumps and A.C. induction motors of various specifications. The company was incorporated in 1983 and established its state-of-the-art manufacturing facility at Kathwada, Ahmedabad, Gujarat, India. They are a team of qualified engineers, having vast experience in design, development and manufacturing of centrifugal pumps.

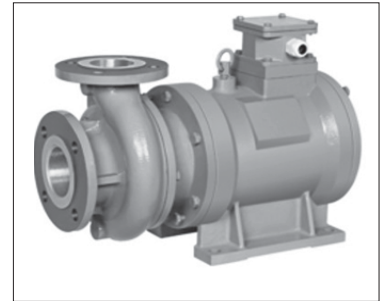

Contact:

Ajay Engineers
Phase-I, Plot No. 269, Opp. Road Number 4
Kathwada GIDC Estate, Odhav, Kathwada
Ahmedabad, Gujarat 382 430
Mob: 92277 92099 • E-mail: contact@ajayengineers.com

Vacuum Pumps

PPI Pumps, an ISO 9001: 2008 certified company, and is one of India's largest vacuum pumps manufacturers. They offer a range of vacuum pumps in different sizes and capacities:

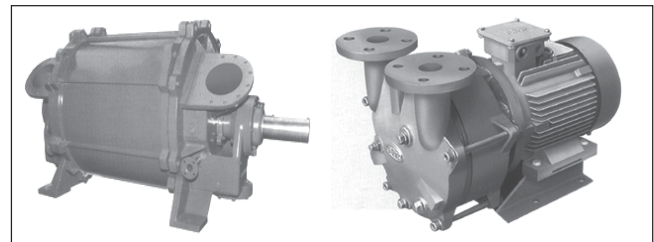

Close Couple Vacuum Pump CC Series (pix, left) – Suction capacity: 20 to 200 m³/hr; Power consumption: 0.75 kW to 5.5 kW; Maximum vacuum: 700 mm of Hg (G). Used in plastic industries and breweries. PRV Series Liquid Ring Vacuum Pump – Suction capacity: 7200 to 16000 m³/hr; Power consumption: 110 kW to 500 kW; Maximum vacuum: 700 mm of Hg 9G); widely used in Pulp and paper industries, and Sugar mills.

Contact:

PPI Pumps Pvt Ltd
14 & 16 C, Phase 1, GIDC Estate, Vatva
Ahmedabad, Gujarat 382 445
☎ 079 – 2583 2274, 3251 6741 • E-mail: sales@pipumps.com

Visit us at: www.ips.co.in

Submerged Sump Pumps for High Temperatures

Egger Pumps India Pvt Limited offers Submerged Sump Pumps for High Temperatures. Molten salt for heat transfer, hardening salt, liquid sulphur or hot slop must be pumped at temperatures between 150° and 450°C. These partly sluggish liquids are usually pumped from pressure-free containers. The temperature, pour point, solid matter, corrosive attack or high vapour pressures normally require sealless submerged sump pumps with customised design details. For safety reasons, a dry-installed pump is not recommended and problematic due to the sealing of the shaft. Egger's high pressure and temperature series is the solution. Egger has developed a special high temperature series for these kinds of applications. Depending on the application, the cantilever design (without bearing and without shaft sealing) or the high temperature submerged sump pumps are used. In the case of granulate media the temperature of both types can be adjusted.



Contact:

Egger Pumps India Pvt Ltd
SF No: 206, Kannampalayam (PO), Suler (Via)
Coimbatore, Tamil Nadu 641 402
☎ 0422 – 268 9855 • E-mail: info.india@eggerpumps.com

Rotary Airlock Valve

Nutshell Engineers offers Rotary Airlock Valve. The features are: the prime function of a rotary airlock (rotary valves) is to regulate the flow from one chamber to another while maintaining a good airlock condition. The product is mainly in dry powder or granular form; in the dust filtration field, a good airlock is essential on cyclone and bag filter applications in order that the manufacturers quoted high dust collection efficiencies can be maintained. Airlocks are also important in the pneumatic conveying industry, where products are regulated into a pressure or vacuum conveying line while minimising air leakage. The company is a premium manufacturer, importer, trader, and exporter of flexible connections, relief valves, safety valves, explosion vents, rupture discs, flame arrestors, etc. Manufactured in accordance with industry-set norms and regulations, these products are known for their seamless finish, dimensional accuracy, longer functional life.



Contact:

Nutshell Engineers
F-18, Basaveshwar Industrial Premises Vishweshwar Chowk
Plot No. 2, Sector 10, Thergaon, Pune, Maharashtra 411 026
Mob: 94220 17122, 77740 61105
E-mail: info@nutshellengg.in

Hydraulic Bending Press

Hercules Roll Forming Machines offers an extensive range of Hydraulic Presses commonly referred as Press Brakes. A press brake is a machine used for bending sheet metal and metal plate, most commonly sheet metal. It forms predetermined bends by clamping the workpiece between a matching top tool and bottom die. Two C-frames from the sides of the press brakes are connected to a table at the bottom and on a movable beam at the top. The bottom tool is mounted on the table and with the top tool mounted on the upper beam. The offered products are fabricated by making optimum utilization of premium quality raw material and components that ensure durability and uninterrupted functions at the users' end. In order to cater the evolving demands of the clients the company has made these products available in different specifications. Parameters – Strip Width: Up to 4000 mm; Strip Thickness: 2 mm; Speed Up to 5 strokes/min; Mechanism: Hydraulic.



Contact:

Hercules Roll Forming Machines
Plant-I: C-113, Bulandshar Road, Indl Area
Ghaziabad, Uttar Pradesh 201 002
Mob: 99589 43311 / 981032 86042
E-mail: rfm.hercules@gmail.com

Push Button Safety Quick Release Coupling

Siemag offers Push Button Safety Quick Release Coupling. The features are: Siemag introduces the all new push button safety quick release couplings, the 2 stage release mechanism prevents hose whipping that cause injury that could result from accidental disconnection; it also prevents scratches or damage to working surface due to the contoured body with round edges; on pressing the button once the air in the releases instantaneously and on pressing the button the second time the plug gets released from the socket; its features include: 2 stage release action; press button once: instantaneous pressure relief; press button twice: instant disconnection; impact and scratch resistant; eliminates hose whips; contoured body; comply to ISO 4414. The company is a certified ISO 9001:2000 company, was established in the year 1959 primarily for the manufacture and supply of field power accessories especially in the field of pneumatics.



Contact:

Siemag Industries
R. K. Industry House, E, Walbhat Road, Vakil Industrial Estate
Cama Industrial Estate, Goregaon, Mumbai 400 063
Mob: 77188 75757, 77109 20909 • E-mail: info@siemag.net

Breather Valves

Caliber breather valves are meant for enclosed bulk storage tanks in the petroleum and other industries. These valves are used as a safety measure to prevent the tanks rupturing or collapsing during filling in and draining out and also to take care of thermal expansion of fluids and consequent pressure build ups. These valves are constructed out of conventional materials and based on the fluids being stored, the valves can be offered in other materials like AISI 304/316, etc. Basically this valve is a combination of pressure relief valve and vacuum breaker put together in a simple and convenient pack. These valves are offered in space saving simple designs, in both flanged and screwed constructions and come in sizes from 50 mm to 150 mm NB. Breather valves can also be furnished with flame arresters and desiccators as per the requirements of the customers.



Contact:

Caliber Valves Pvt Ltd

101, 1st Floor, 4th St, AH Block, Shanthi Colony

Anna Nagar, Chennai, Tamil Nadu 600 040

☎ 044 – 4350 0192 • Mob: 89397 34853

E-mail: info@calibervalves.com, mktg@calibervalves.com

Rotary Gear Pump, Type HG SX

The Rotodel gear pump Type HG SX is all SS-316 self-priming bi-directional positive displacement rotary pump, fitted with Teflon coated dry running DU bush bearings. Three piece design makes the pump easy cleanable, easy maintainable simply by removing four dom nuts on back cover. Mechanical seal is optional for Teflon gland packing. The mounting bracket converts the pump to foot mounting and facilitates to align the pump with electric motor of appropriate ratings on base plate at same frame height. All sizes of HG SX pumps are designed to run at 1440 RPM up to viscosity of 500 CST, however small size pump up to 1" can be run at 1440 RPM safely, even at higher viscosity up to 1000 CST but with additional horse power, for higher sizes reduce the speed to 960 RPM. This compact and efficient SS pump finds different applications for handling food products like ghee, butter fruit pulp, vegetable souse, kanji, etc. They are also used in pharmaceutical application for handling sugar solution, glycerin, glycol etc.



Contact:

Del Pd Pumps & Gears (P) Ltd

113 GIDC Estate, Wadhwan, Surendranagar, Gujarat 363 035

☎ 02752 – 243 047, 243 678 • Mob: 99988 17576

E-mail: info@delpump.com

Subscription Order Form

To,
The Circulation Manager
Product News Publication
104, Sudama Yash, Nr. Ramkrishna Hotel
Kelkar Cross Road, Ram Nagar, Dombivli (E), Thane 421 201

Dear Sir,

I / We would like to subscribe **Industrial Products Source**.

Please commence my/our subscription with the _____ (Month & Year) Issue. I / We enclose the payment of Rs. _____

Name _____

Address _____

_____ Pin code _____

Telephone _____ Mobile No. _____

Date: _____ Signature _____

Industrial Products Source

Visit us at: www.ips.co.in / www.industrialproductssource.com

1-Year (12 issues) ₹ 300/-

2-Year (24 issues) ₹ 550/-

3-Year (36 issues) ₹ 750/-

Subscribers who wish to receive magazine through courier, will be charged extra

in favour of **PRODUCT NEWS PUBLICATION**,

by "A/c. Payee" Draft / Cheque No. _____

Dated _____ of Bank _____

Our Bank details for NEFT payment Transfer:

Name of the company: **PRODUCT NEWS PUBLICATION**

Name of our bankers: IDBI BANK, Dombivli (East Branch)
Thane Dt.

A/C NO: 118102 00000 6569

Nature of Account: Current

IFS Code: IBKL000455

Kitz Butterfly Valves

Zenith Trading Co offers Kitz Butterfly Valves. The features are: in order to fulfill the ever changing demands of their clients, they have been engaged in offering a quality range of kitz butterfly valves; these valves are widely appreciated for their durability, resistance against rust, and smooth working; the products are developed under the supervision of experts, employing the latest technological machines and tools. Moreover, these valves are tested on various parameters before the final delivery in order to offer a tested range to their clients; their features include: handles for extreme pressure; efficient design; dimensional accuracy; a fine finish and workout; a rigid and sturdy design; negligible pressure loss; and everlasting superior performance. The company is one of the most well known dealers, manufacturers, wholesalers, traders, and retailers of kitz valves, water meters, industrial valves, metal valves, electromagnetic flow meters, and much more.



Contact:

Zenith Trading Co

29/61 Sembudoss St, Parrys, George Town, Chennai 600 001

☎ 044 – 3295 7270, 2522 9760

Mob: 98411 30142 • E-mail: kaizardhaman@vsnl.net

Clear Water Pumps

Darling Pumps Pvt Ltd offers Clear Water Pumps. The features are: these darling openwell submersible pumps are not only unique in design but are also very compact, sturdy, and highly reliable. Offered pumps up to 120 HP and head range up to 140 mtrs.; these pumps come with mechanical seal and ball bearing designs and thus can be installed in inclined positions as well; these pumps can be customized for oil-filled motors or air-filled motors as well; their applications include: this range of darling open well submersible clear water pumps consists of S and M series pumps. These pumps are not only ideal for various agricultural applications but are also very popular for many industrial applications as well. The company, with its expertise spanning over 35 years, has been the chief architect of the submersible pump revolution in India. With every new and innovative product line, it has set a benchmark for others to follow and has thus always kept one step ahead of the market.



Contact:

Darling Pumps Pvt Ltd

340/2 Tigaria Badshah, Nr: Agarbatti Complex

Sanwer Road Indl Estate, Indore, Madhya Pradesh 452 015

Mob: 99819 92833 • E-mail: dpplin@darlingpumps.in

Submersible Portable Pumps, PST Series

MBH Pumps (Gujarat) offers PST Series Submersible Portable Pumps, also known as cutter pumps, these pumps are fully foldable, vertical, closed coupled single stage submersible motor pumps. These pumps are your solution for critical application. Technical Specifications – Head: 32 metres; Capacity: 170 m³/hr; HP: 0.5 to 10; RPM: 2900/3550; MOC: Cast Iron, Aluminium, Stainless Steel; Frequency: 50/60 Hz. Uses: Automatic dewatering of Pits; Yards and basements subjected to flood risk; Portable applications. The Company's products range includes: Centrifugal Self Priming Pumps, H₂O Series Centrifugal End Suction Pumps, Ni-HARD Series Submersible Slurry Pumps, DC Series Submersible Dewatering Pumps; Monoblock Pumps, etc.



Contact:

MBH Pumps (Gujarat) Pvt Ltd

Plot No: 14, GIDC Indl Estyate, Naroda

Ahmedabad, Gujarat 382 330

☎ 079 – 2282 3066, 2282 1018

E-mail: marketing@mbhpumps.com

Gate Valves

Mawa Engineering Works manufactures Gate Valves. Its design and mfg: API 600, API 6D, BS 1414; Pressure Rating: Class 150 to 2500; Pressure and temperature ratings: ASME B16, 34; Size: 50 mm to 400 mm; End Connection: ASME B16.5; Face to face dim: ASME B16.10; Inspection and Testing: API 598; Operation: Hand wheel, Gear operated, Electrical; Material of Construction: WCB, CF8, CF8M, CF3M, CN7M, Hastelloy C and all alloys; Special: Pressure seal bonnet and bellows seal gate valves. The Company's products range includes: Butterfly valves, Globe valves, Swing Check valves, Ball valves, Dual Plate check valves, Plug valves, Wafer check valves, Double Block and Bleed valve, Control valve, Torque Tester (electronics), Pipes and Fittings, Strainer Y Type, Conical Strainer, etc.



Contact:

Mawa Engineering Works

5-6 Darbar Manzil, B/h: Jai Hind Hotel, Sarkhej,

Ahmedabad, Gujarat 382 210

Mob: 93270 13245 • E-mail: mawaenggworks@gmail.com

Rotary Conductive Plastic Servo Potentiometer RCP-50-A

Pankaj Potentiometers introduces the all-new RCP-50-A, a Rotary Conductive Plastic Servo Potentiometer engineered for high-accuracy position sensing and reliable performance in demanding environments. Specifications: 50 mm Diameter, 25 mm height, 6 mm diameter Stainless Steel Shaft, 15 m long 1K, 5K and 10K Ohms. Key Features: Infinite Resolution – For smooth, continuous manual or mechanized rotation; Low CRV – Ensures consistent signal with minimal variation; Gold-Plated PCB – Enhances conductivity and corrosion resistance; Precious Metal Multi Wire Wipe Contact – For excellent contact reliability; Black Anodized Aluminum Housing – Durable and corrosion-resistant finish; Stainless Steel Shaft – Built for strength and longevity; Relimate Connector PCB – Easy and reliable electrical connectivity; Long Rotational Life – Built for extensive operating cycles; Double Ball Bearings – Smooth, low-friction motion for precision performance; Spring Hard Stainless Steel C Clamps for Mounting – Secure and stable installation; Designed to deliver stable output across wide temperature ranges and perform reliably even in high moisture environments, the RCP-50-A is the ideal solution for precision applications.



Contact:

Pankaj Potentiometers Pvt Ltd
Udyog Mandir No: 1, 201-B, 217, 218, 7-C, Pitamber Lane
Mahim (West), Mumbai 400 016
Mob: 98690 50801
E-mail: pankaj.potentiometers@gmail.com

Industrial Solutions

Destiny Enviro Solutions provides Industrial Solutions under one roof such as Vibratory Deburring and Finishing Machines – Enhance the finishing process; Industrial Parts Washing and Cleaning – Keep your components in top shape; Consumables – High-quality parts, accessories, media and chemicals; Repair and Reconditioning – for all types of vibratory and barrel finishing machines; EOT Cranes and Lifting Solutions – Heavy-duty lifting made easy; Fire Protection Systems and MEP Services – Safety and efficiency you can trust; Service Support – Continuous support whenever you need it.

Contact:

Destiny Enviro Solutions Private Limited
246/5 Kuruli Road, Chimbli, Tal-Khed
Pune, Maharashtra 410 501
Mob: 90046 24913 / 77383 66910
E-mail: sales@destinyenviro.com

Hydraulic & Pneumatic Products

Hindustan Hydraulics & Pneumatics offers a range of Hydraulic products like: Hydraulic Pumps, Directional Control Valves, Flow Control valves, Directional Control Valves, Pressure Control Valves, Modular Valves, Proportional Valves, Hydraulic Filters, Accumulator, Automatic Lubrication Units, Air Blast Oil Coolers, Heat Exchangers, etc. Pneumatics: Pneumatic Actuators, Direction Control Valves, Flow Control Valves, Process Solenoid Valves, Air Filters, Regulators, Lubricators, Manifolds, Vacuum Ejectors, Vacuum Cups, Rotary Actuators, Grippers, Air Boosters, Air Dryers, Auto Drain Valves, Digital Pressure Switches, Digital Flow Switches, Tubes and Fittings, etc. Manual and Automation Valves: Ball Valves, Butterfly valves, Gate valves, Globe valves, Pressure Relief valves, Pressure Reducing valves, Diaphragm Control valves, Process Solenoid valves, Angle Type Pneumatic Control valves, Non-return Valves, etc. Hoses: Hydraulic hoses, Air and water Rubber hoses, Steam Rubber hoses, SS Corrugated Hoses, SS Braided Teflon hoses, High Pressure Jack Hoses, Nylon Braided PVC hoses, Steel Wire Braided Thunder Hoses, PVC duct hoses, Suction hoses, Fuel Transfer Hoses, Heat Resistant Carbon free hoses, Silicon hoses, etc. Tubes and Fittings: CS, SS, Copper Tubes, Hex Nipple, Male/Female Connector, Male/Female Elbow, Male/Female Tee, Male Branch, Run Tee, Bulkhead, Banjo, Washer, etc.



Contact:

Hindustan Hydraulics & Pneumatics
New No: 265, Old No: 127
Thambu Chetty Street, Chennai 600 001
☎ 044 – 2534 3066 / 2534 5625
E-mail: hhp@hindustanhydraulic.in

Reverse Pulse Jet Bag House Dust Collectors

Balaji Filter Tech offers Reverse Pulse Jet Bag House Dust Collectors that are centralized dust collecting systems for industries where dust is emitted from most of the processing machines inside the factory. Dust collectors for each machine or so expensive and occupy more space, to avoid these difficulties, bag house dust collectors are made as outdoor dust collectors, which are connected to a several machines through a centralized ducting system. Applications: Commercial Buildings, Industrial, Food and Beverages, Spray Paint Booths, Healthcare, Schools, etc.

Contact:

Balaji Filter Tech
SF No: 33/1B, Kannampalayam Road, Peedampalli PO
Coimbatore, Tamil Nadu 641 016
Mob: 99522 30394 / E-mail: balajifilters@gmail.com

Rotary Vane Oil Lubricated Vacuum Pumps

Shree Siddhivinayak Industries, an ISO 9001-2015 Certified Company manufactures Minivac™ Rotary Vane Oil Lubricated Vacuum Pumps, which are cooled versions. An oil-water cooler is available for high ambient temperatures or for heat recovery. The exhaust air is cleaned in a built-in mist filter with a very high separation efficiency ensuring

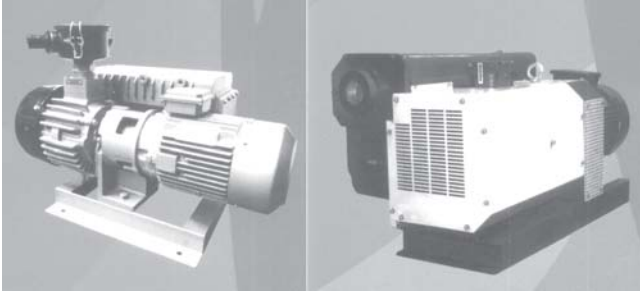

oil free operation in all working conditions. Use of specially treated vanes has the advantage of low friction thus increasing pump life. These pumps have vacuum feed lubrication which ensures positive feed lubrication to all

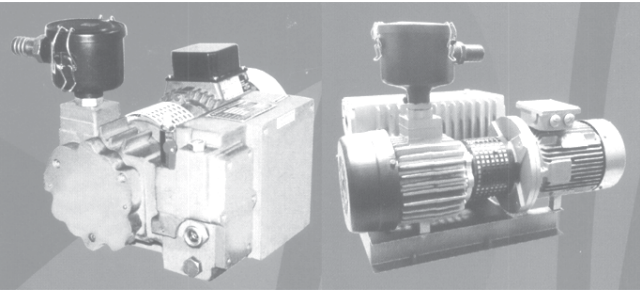

rotating and frictional contact parts. SVL Series: Minivac make SVL Series are positive displacement oil lubricated low vacuum rotary vane vacuum pumps available in direct drive and belt driven options; Use of specially treated vanes ensure negligible wear and tear thereby increasing pump life; These pumps have vacuum fed lubrication, which ensures positive feed lubrication to all rotating and frictional contact parts. Applications are in industries like Pharma: Capsule filling/Capsule printing machine and other Pharmaceutical machines; Food Processing: Bottle Filling Plants, Bottle Holding; Packaging: Blister Packing/Labelling Machines. Special Accessories are available on demand: Additional External Filters; Water Cooler; Oil Cooler, Oil Heater; Non-return Valves; Vacuum Gauge; and Vacuum Receiver.

Contact:

Shree Siddhivinayak Industries
Plot No: 19, Kashimira Indl Estate, Off Western Exp Highway
Mira, Dist. Thane, Maharashtra 401 104
☎ 022 – 2845 8372 / 2845 7073
E-mail: response@minivacpumps.com

**Subscribe to
Industrial Products Source
at ₹550/- for 2-year.**

Three-Way Shut-off Ball Valve with Actuator

Micro Pneumatics Pvt Ltd offers Three-Way Shut-off Ball Valve with Actuator. The Three Way Ball Valve is configured with Shut-off. The three ports are configured as one at bottom and one each on the right and left of the valves. With this, three way shut-off ball valve, the two different medias can flow separately from either of the two sides of the valve to the bottom side of the valve and can be stopped. Alternately the three-way shut-off ball valve is featured for diverting a single media from the bottom port of the valve is either side, with shutting off the media. With a single three way ball valve shut-off is also achieved. Mounting Interface: ISO 5211; MOC of the Body: WCB, CF8, CF8M, CF3, CF3M (special on request); Trim: CF8, CF8M, CF3, CF3M (special on request; Seat/Cavity Filler: PTFE, RPTFE (Special on request); and Size: ½" to 8".

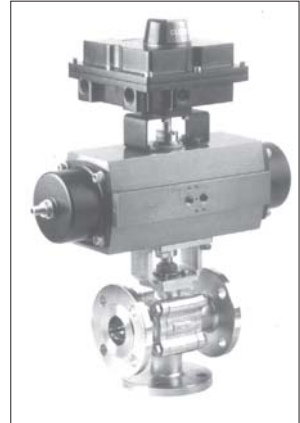

Contact:

Micro Pneumatics Pvt Ltd
Plot No: 133-134, Vasai Municipal Indl Area, Umela Phata
Papdy, Vasai Road (W), Dist: Palghar, Maharashtra 401 207
☎ 0250 – 232 0458 • Mob: 83089 59200 / 83548 00888
E-mail: micropneumatics@vsnl.net

PFA/Antistatic PFA/FEP/PVDF/PP Lined Valves

Dipflon Engineering & Co, an ISO 9001:2015 Certified Company offers a range of PFA/Antistatic PFA/FEP/PVDF/PP Lined Valves, which includes: Lined Ball Valve (available



in 2-way and 3 way); Lined Swing Check Valve; Lined Plug Valve; Lined Butterfly Valve (available in semi-lug and full leg); Lined Diaphragm Valve; Lined Sampling Valve; Lined Ball Check Valve. The Company also offers all types of Lined Pipes and Pipe Fittings such as Lined Tee, Lined Y Type strainer, Lined Basket Type Strainer, Lined Double Window Sight Glass, Lined Spool Pipes, Lined DIP Pipe, Lined Elbow, PTFE Expansion Bellow, etc.

Contact:

Dipflon Engineering & Co
B-413, BG Towers, Nr: Delhi Darwaja, Shahibaug Road
Ahmedabad, Gujarat 380 004
☎ 079 – 2562 4003 • Mob: 98987 94440 / 92276 84378
E-mail: info@dipflon.com

Portable Oil Free Vacuum Pumps cum Compressor

AVI Scientific (India) offers Portable Oil Free Vacuum Pumps cum Compressor in different models. Features of Model No: AVI-15 (pix, top) – Max Flow: 15 litres/min; Max Vacuum: 22" Hg; Max Pressure: 25 PSIG; Approx. Weight: 2.7 kg; Motor HP: 1/20 HP; Approx. Dimensions: 175 x 111 x 140 mm. Model No: AVI-45 (pix, bottom) – Max Flow: 45 liters/min; Max Vacuum: 22" Hg; Max Pressure: 35 PSIG; Approx. Weight: 6.2 kg; Motor HP: 1/8 HP; Approx. Dimensions: 220 x 120 x 180 mm. The Company's other products range includes: Digital Friability Test Apparatus, Digital Tablet Disintegration Apparatus, Digital Leak Test Apparatus, Microprocessor Dissolution Test Apparatus, Microprocessor Flame Photometer, Digital Melting Point Apparatus, Microprocessor Disintegration Test Apparatus, Fully Automatic Autoclave, Microprocessor KF Titrator, Fully Automatic Colorimeter, Digital Auto pH Meter, Microprocessor Conductivity, TDS, Salinity Meter, Turbidity Meter, Digital Colony Counter, Filtration Assembly, Blood Roller Mixture, IR Moisture Balance (Analog), Digital IR Moisture Balance, etc.

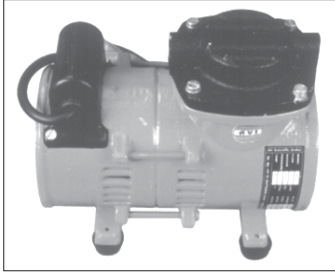

Contact:

AVI Scientific (India)
A-221, Amar Gian Industrial Estate, Opp: Khopat S T Stand
LBS Marg, Thane (West), Mumbai 400 601
☎ 022 – 2547 7638 / 2547 7640 • Mob: 80489 72250

Cube Moulds

Madhu Machines & Systems Pvt Ltd offers Cube Moulds that are an efficient solution for high volume production. With the ability to double the effective number of cavities without purchasing additional machinery, it is an excellent choice to reduce both capital and long-term energy costs whilst increasing productivity and lowering the costs per unit. The Company's products range includes: High Cavity Single Face Systems, Single Valve Gate Technology, Nexus Pre-Assembled Systems, Tip less Nuts, etc.

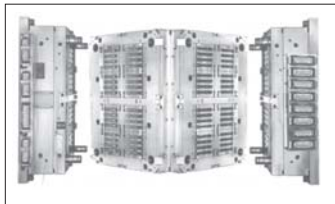

Contact:

Madhu Machines & Systems Pvt Ltd
A-4/5, Anurag, Ganeshkrupa Society, Chikwadi
Haripura, Vadodara, Gujarat 390 007
☎ 0265 – 235 3886 • E-mail: meeta@madhu-group.com

Vertical Multistage High Pressure Centrifugal Pump

Abirami Engineering Company offers Vertical Multistage High Pressure Centrifugal Pump. Its In-line design enables installation of the pumps in horizontal one pipe systems. Flange or with Victaulic coupling with equally sized suction and discharge ports. Stage construction with Stainless Steel impellers, diffusers and outer tube, Pump shaft and Motor shaft are of IEC Standards. All wetted parts of pump are made of high grade corrosion resistant stainless steel. These pumps are driven by Totally Enclosed Fan Cooled (TEFC) high efficiency. AC Induction motors. Features: Capacity up to 200 m³/hr; Head up to 300 m (30 bar); Speed 2900 RPM max; Delivery DN25 (1") to DN 150 (6"); Energy Efficient; Compact and Aesthetical Design; Corrosion Resistant; Reliable Sealing; Easy Maintenance; Durable; Light Weight; Low Noise Level. Operating Ranges: Capacity up to up to 200 m³/hr; Head up to 300 m (30 bar); Speed 2900 RPM max; Delivery DN25 (1") to DN 150 (6"). Applications: Water Supply; Fire Fighting; Industrial Pressure Boosting; Liquid Transfer; Water Treatment; Building Industry; Dairy; Irrigation; Power Plants.



Contact:

Abirami Engineering Company
25 Vivekanantha Nagar, Street No: 1, P N Pudur
Coimbatore, Tamil Nadu 641 041
☎ 0422 – 244 3813 • Mob: 93631 45603 / 93623 45603
E-mail: abiramipumps@gmail.com

J&T EcoCleaner

CAC Admixture Company introduces Slurry Additive for the breaking up of Slurries before disposal. The J&T Eco-Cleaner Slurry Additive is used to improve solid content in fresh slurries and as a flocculation agent for used slurries to separate solids from fluids for easy disposal of surplus slurries. Product Description: Appearance is colorless/light yellow powder; Solid content: 90% Bulk; Ionic charge: high cationic charge; Slurry Properties (10% in Tap water); Viscosity: < 300 cPs; pH value: approx... 3 to 7.

Contact:

CAC Admixture Company
Plot No: D-9/4, Chemical and Alkali Complex
Turbhe MIDC, Navi Mumbai 400 705
☎ 022 – 2087 2752 / 2087 1847
E-mail: enquiry@cac-admixtures.com

Horizontal Mixed-Flow Pump, Series SMF

Sintech Precision Products Limited offers Horizontal Mixed-Flow Pump SMF. These SMF Series pumps are single-stage centrifugal pumps suitable for handling pure or contaminated liquids in large quantities. These pumps are of robust construction and have long working life. These pumps are highly efficient resulting in low energy consumption. Capacity (max.): 7000 m³/hr; Head (max.): 45 m; Temperature: 50°C; Working Pressure: 4 kg/cm². Other products offered by Sintech are: Vertical Sump Pump, Self-Priming Pump, Rota Pumps for Magma Masecuite application in sugar industry; Torque Flow Pumps, Process Pumps, Non-Clog Pumps, Vertical Pumps, etc. The Company supplies pumps for the following applications: Water and Waste water, Sugar, Energy, Steel, Pulp and Paper, and Process industries.

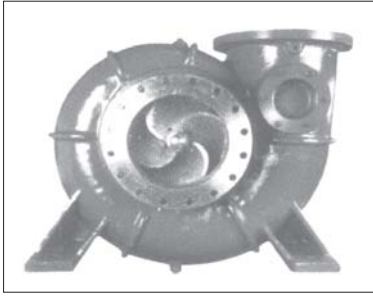

Contact:

Sintech Precision Products Limited
C-189-190 Bulandshahar Road Industrial Area
Site No: 1, Ghaziabad, Uttar Pradesh 201 001
☎ 0120 – 417 6000, 286 6320
E-mail: sales@sintechpumps.com

Vertical Sump Pumps

Superflow SVP Vertical Sump Pumps are specially designed for long life and trouble free performance. The Special design of Intermediate journal bearings and high machining accuracy maintained by Superflow gives added life to pumps. The pumps are used as dry pit and wet pit and driven by vertical flange mounted motor where NVSHR not required. The pumps are available up to 5000 mm shaft length and max flow up to 150 m³/hr at 15 m head. These pumps are suitable for coal washery, mines, cement plants, irrigation, sea water, effluents, etc. Superflow Pumps Pvt Ltd, an ISO 9001-20154 Certified Company, also offers Molten Sulfur Sump Pump, Horizontal Chemical Process Pump, Cartridge Chemical Process Pump, Semi-Open Impeller Process Pump, Self-Priming Pump, etc.



Contact:

Superflow Pumps Pvt Ltd
Plot A-498, TTC Industrial Area, MIDC Mahape
Navi Mumbai 400 710
Mob: 97691 22842 / 97691 92843
E-mail: info@superflowpumps.com

Horizontal Axial Flow Pump

JEC AF-Series Axial Flow Pump is unmatched in the industry for high volume/low head pumping requirements, especially when corrosive and abrasive solutions are involved. Features: Extended service life, mechanical reliability, custom engineering, and a wide range of materials allow the AF-Series to stand out as the leader in the field.



Performance Data –

Size: 5 to 36 inch (125 to 900 mm); Capacity: 10000 m³/hr; Head: Up to 9 m; Temperature: 150°C; Material: Available in MS, SS, Duplex, Super Duplex Steel and Alloys. Applications: Evaporator and Crystallization processes (brine, seawater); Continuous circulation of corrosive/abrasive solutions; Phosphoric acid, slurries, process wastes; Pulp and Paper industry; Regeneration Plants; Sugar Industries; and Fertilizer.

Contact:

Jay Ambe Engineering Co
Survey No: 416 & 1464, Near Water Canal
Kothiya-Kuha Road, Village Kuha, Taluka Daskroi
Dist: Ahmedabad, Gujarat 382 433
Mob: 99786 28298 • E-mail: sales@jecwoodland.com

High Pressure Pumps

Yuken HPV Series Pumps are the High Pressure vane Pumps, which come with the double lip vane design that gives high resistance to particle contamination and better pump life. Volumetric efficiency in the range of 94% ensures less power loss and heating. These are specially designed for low noise level and high efficiency even at high pressure and speeds. HPV Series pumps are designed for high pressure application. The Company's products range includes: Variable Displacement Piston Pumps, Vane Pumps, Standard Pumps, Gear Pumps; Flow Control Valves, Pressure Control Valves, Directional Control Valves, Modular Valves, Direct Operated Pressure Relief Valve, Cartridge Valves, Proportional Valves, High Response Type Proportional Electro Hydraulic Valves, High Speed Linear Servo Valves, etc.



Contact:

Yuken India Limited
P B No: 5, Koppalthimmanahalli Village, Malur-Hosur Road
Malur Taluk, Kolar Dist, Karnataka 563 130
Mob: 98801 87244 • E-mail: marketing@yukenindia.com

Teflon Lined Mechanical Seal Pumps

Fluorolined Equipment Pvt Ltd offers Teflon Lined Mechanical Seal Pumps PLX Series. Its Salient Features: Thick PFA/FEP Teflon moulded in-situ in Cast Steel (WCB) by

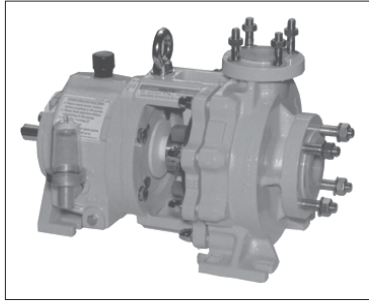

high pressure moulding technique; Rigid frame and casing feet to reduce the effect of pipe loads on alignment; All castings and inserts of wetted parts produced by investment casting process; Heavy duty shaft and bearings designed for minimum deflection and for achieving longer life under tough operating conditions; Shaft sealing to accommodate conventional seals, double seals, special seals without any external water cooling; Semi-open impeller acknowledged best design for chemical services – solids handling, stringy material, corrosives and abrasives; Back pump out vanes to minimize seal chamber pressure. Industries served are:

Steel Pickling Plants; Acid Regeneration Plants; Pesticide and Insecticide Plants; Caustic Chlorine Plants; Dyes and Intermediates Plants; Pharmaceutical and Bulk Drug; Environmental Industrial waste water treatment (ETP), Scrubber recirculation; Electroplating; Power Plants; Auto Paint Shops; Chlorinated Paraffin Wax (CPW) industries; and Bromine Recovery plants.

Contact:

Fluorolined Equipment Pvt Ltd
Unit No: 3, 2nd Floor, Hind Service Industrial Estate
Shivaji Park, Mumbai 400 028
☎ 022 – 2446 0630 / 2446 0631
E-mail: office@fluorolined.com

Silicone Products

Elkay Chemicals is a specialty and performance silicone manufacturer. Elkay manufactures oils, resins, surfactants, functional silicones, emulsions, and formulations for cosmetics, construction/coatings, pharmaceuticals, among others. The Company commits to the highest EHS and sustainability standards in manufacturing; and specializes in innovative customer-specific approaches resulting in quality and often customized solutions.

Contact:

Elkay Chemicals Pvt Ltd
Bremen Business Center, Level 5, Aundh
Pune, Maharashtra 411 007
☎ 020 – 6522 1202 • Mob: 98220 53558 / 93565 10599
E-mail: information@elkaysilicones.co.in

Three Lobe Blower & Vacuum Pump

TMVT Industries Pvt Ltd offers Three Lobe Blower and Vacuum Pump. Its Features: Lower Energy Consumption: three lobe design control backflow pressure to rotor thus



reduce energy consumption; Lower Noise: Pressure pulses are the major noise source of blower; three lobe design can efficiently reduce noise by approx. 5 dB; Longer Bearing Life: Less vibration transmitted through the lobe results approx. 20% longer bearing life. Conventional blowers result pressure pulses and vibration add to power consumption and shortens the life of every bearings, gear and other drive train components. Three Lobe Reduce Vibration and Noise: three lobe blowers are new series Roots type blowers. Rotors are manufactured on high precision CNC machines ensuring high performance, lower noise level and vibration. Features: Wide range for air volume – pressure and vacuum. Bore: 32 NB ~375 NB (1.25" ~ 15"); Capacity: 6 ~16500 m³/hr; Pressure: 0 ~12000 mm WG Air Cooled and Water Cooled; Vacuum: -5000 mm WG. Stable air flow and less pressure variation; Oil free air; Simple construction and easy maintenance; all bearings are lubricated by oil.

Contact:

TMVT Industries Pvt Ltd
Manek Mahal, 5th & 7th Floor, 90 Veer Nariman Road
Churchgate, Mumbai 400 020
☎ 022 – 2283 0060 / 3521 9523
E-mail: tmvtmumbai@tmvt.com

SS Tubing/Impulse Tubing

Trueway Engineering supplies SS Tubing/Impulse Tubing; Features – Size: 1/16" to 2" OD; Thickness: As per specification; Length: Random Straight Lengths of 4 to 7 m. Coiling Possible for smaller size Tubing Optionally PVC Insulation can be provided; Type: Soft Fully Annealed Seamless; Grades: ASTM A 269/A 213, etc. MOC: SS 304/304L/316L/321, Monel, etc.

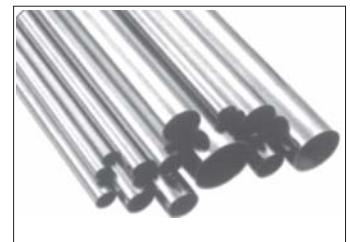

Trueway is a manufacturer of a range of products like Instrument Erection Hardware/Instrument Piping Components such as Compression Tube Fittings, Ball/Needle/Gate/Globe/Check Valves, Manifolds, Air Headers, Condensate Pots, Syphon, Snubbers, Quick Release Couplings, Socket Welded and Butt Welded Pipe Fittings, Flanges, etc.

Contact:

Trueway Engineering Industries
Trueway House, Plot No: 535/14-15, Sonawala Cross Rd No: 2
Nr: M K Industrial Estate, Goregaon (East), Mumbai 400 063
☎ 022 – 2685 2241 / 2685 1052
E-mail: truewayeng@gmail.com

Rotary Vane Type Vacuum – Pressure Pumps

Promivac offers Rotary Vane Type Vacuum Pressure Pumps Single Stage, Air Cooled, and V-Belt Driven. Self-Lubricated and easily maintainable for efficient and care free Vacuum and Pressure needs.

These have low oil consumption and are designed for self-lubrication of all the vital components of the pump. The oil thus used does not contaminate the air, but is baffled from the exhaust, gets collected and returns to the



oil chamber and serves for long. Applications: Widely used for Cow milking machines, Bottle Filling, Blister Packing, Tea, Tablet and Pouch Packaging, Vacuum Sealing, Labeling, Printing, Vacuum Forming, Food Processing, Filtration, Vacuum Sealing, Conveying, Evacuation, Distillation, etc. The Company's products range includes: Rotary High Vacuum Pumps (V-belt, Direct Driven and Monoblock Type), Water-ring/Liquid-ring Vacuum Pumps, Vacuum Pressure Pumps, Suction Pumps, Milking Vacuum Pumps, Mechanical Vacuum Boosters, Turbine, Side Channel, Twin Lobe (Roots) and Centrifugal Blowers, Diaphragm, Piston and Carbon Vane Type Oil Free Vacuum Pressure Pumps, Centrifugal Chemical Process Pump in Gland/Mechanical Seal and CI/PP/SS-316 construction, Seal-less Magnetic Driven Pumps, Non-Clog Mud/Sewage, Sludge Suction Pumps, Hydraulic Test Pumps, Barrel Pumps, etc.

Contact:

Promivac Pumps Pvt Ltd

3575 NS Marg, Darya Ganj, New Delhi 110 002

☎ 011 – 2328 1082 / 2327 3965

E-mail: info@promivacpump.com

Quick Exhaust Valves

Duncan Engineering Limited offers Quick Exhaust Valves G ¼" to G ¾", which are used to increase the cylinder piston speed by around 2 times. The Company's other products range includes:

Pulse Valves, 2-Way Solenoid Valves, Angle Seat Valves, Flow Control Valves, 5/2 Directional Control Valves, Excel Valves, Max Flow Valves, Modular Spool



Valves, Direct Acting Midget Solenoid Valves, Vertical Poppet Valves, ISO Valves, Namur Valves, Basic Double Poppet Valves; Air Line Accessories, Tubing and Fittings, Positioner Cylinders, Control Panels, Rotary Actuators, Air Limit Switches, etc.

Contact:

Duncan Engineering Limited

F-33, MIDC, Ranjangaon, Karegaon

Tal: Shirur, Pune, Maharashtra 412 209

☎ 02138 – 660 066 • E-mail: pbu@duncanengg.com

Ball Valves with Automations

JossMin's Ball Valves and Automations Private Limited's Ball Valves with Automations are designed as per API 6D/ASME standards and offers a Blow-out-proof multi-sealed

stem with a Belleville washer set over the Gland fastened with Gland nuts assuring Zero Leakage and preventing Atmospheric leakage. The designs have provision for the Antistatic feature and are Fire safe for Flanged End Valves. All Critical components comprising Metal Trims as well as Seats are finished to an extent that reflects durability, ensures Tight Shut-off and assures extended life. Specifications – Port Type: Full Bore/Regular Bore/E-Seg; Construction: Two piece/three piece; Design: Fire-Safe/Non Fire safe, Seated/Cavity Filled,



Floating/Trunnions; Variations: 2-Way, Jacketed, Tri-port, T-port, L-port, 3-Way Diverter, and others. JossMin manufactures a wide range of valves and valve automation systems. The Company offers different Ball valves, Butterfly valves, and Flush Bottom valves in a wide range of sizes, pressure ratings and materials. All valves are available in multiple end connections such as Flanged end, Triclover end, Screwed end, Socket weld end, Butt weld end, Orbit weld end and many more. Industries used by these products are: Pharmaceuticals, Food and Beverages, Chemicals and Pesticides, Paints, Polymers, Pigments, and others.

Contact:

JossMin Valves and Automations Private Limited

Plot No: 2, Survey No: 46, Manas Industrial Hub

Chinchpada, Waliv Road, Vasai East

Dist: Palghar, Maharashtra 421 208

Mob: 70280 25111 / 70280 25222

E-mail: info@jossmin.co

SS/Brass Compression Fittings

Safe Power Industries supplies a range of products like Stainless Steel / Brass Compression Fittings, Conduit Pipes and Accessories, Stainless Steel Tubes and Fittings, Copper Tubes and Fittings, Earthing Materials, Cable Trays, Cable Glands, etc.

Contact:

Safe Power Industries

Gala No: 1, Jamnadas Sadan, B/h: Hotel Airways

LBS Road, Ghatkopar (West), Mumbai 400 086

☎ 022 – 6528 7396 • Mob: 09214 10957 / 93214 10957

E-mail: enquiry@safepowerland.com

Industrial Products Source

A Magazine for Indian Industries since 2004

SPECIAL SECTION SCHEDULE - May 2025 to March 2026

May	2025	ACMEE 2025 Exhibition + Focus: Machine Tools & Automobile Accessories
June	2025	Foundry Equipment, Casting, Forging & Shot Blasting, Boilers & Furnaces
July	2025	Industrial Automation, Instrumentation, Testing & Measuring Instrument
August	2025	Gears & Bearings, Motors & Drives, Clutches & Brakes, Oils & Lubricants
September	2025	Pumps, Valves, Tubes & Pipe Fittings
October	2025	Material Handling & Storage Equipment
November	2025	Electrical & Electronics, Solar, Wind & Alternative Energy
December	2025	22 nd Annual Issue
January	2026	Chemical, Pharma, Bio-Tech & Food Processing Packaging, Pollution Control Equipment
February	2026	Cables, Wires, Connectors, Control Panels Transformers Switchgears & Welding Equipment
March	2026	Diemould India Exhibition 2026 + Focus: Machine Tools, Auto Components Accessories



Area of Circulation (Industry wise)

- Agriculture
- Air Condition
- Airlines & Aerospace Industries
- Atomic Sector
- Automation
- Automobile
- Bio-Tech & Pharmaceuticals
- Boilers
- Banking Sector
- Cement
- Ceramics
- Chemical Plants
- Construction Machinery & Equipment
- Defence
- Electrical & Electronics
- Exporters
- Fasteners
- Fertilizer
- Food & Beverage
- Foundry & Forgings
- Heat Exchangers & Cooling Towers
- Heavy Engineering
- Hydraulics & Pneumatics
- Industrial Safety & Security
- Libraries
- Machine Tools
- Material Handling
- Oils & Refineries
- Paints
- Paper & Pulp
- Petrochemicals
- Plastic & Rubber
- Pollution Control Boards
- Printing & Packaging
- Project Consultants
- Pumps & Valves
- Railways
- Research Institutions
- Steel
- Sugar / Tea
- Testing Laboratories
- Textiles
- Universities
- Welding

Advertisement Tariff

Size	4-Color	Black & White
Full Page (17.5 [W] x 25 [H] cm)	₹ 21,000/-	₹ 14,000/-
Half Page (H-17.5 [W] x 12 [H] cm) (V-8.5 [W] x 25 [H] cm)	₹ 12,800/-	₹ 8,500/-
Quarter Page (8.5 [W] x 12 [H] cm)	₹ 7,200/-	₹ 4,800/-
Double Spread (35 [W] x 25 [H] cm)	₹ 42,000/-	₹ 28,000/-
Cover Pages		4 - Color
Front Cover-Half Page (H)		₹ 24,000/-
Front Cover-Quarter Page		₹ 15,000/-
Front Cover-Strip (H) (17.5 [W] x 6 [H] cm)		₹ 15,000/-
Front Inside Cover		₹ 27,000/-
Back Inside Cover		₹ 27,000/-
Back Cover		₹ 32,400/-
Front Gate Fold		₹ 54,000/-

Home Page	3-Months	6-Months
Small Banner (100 x 100 pixels)	₹ 6,000/-	₹ 10,000/-
Large Banner (240 x 100 pixels)	₹ 8,000/-	₹ 14,000/-
■ Inclusive of Design & Hosting - 12 kb maximum ■ If the advertiser wishes to change the design or any updating in the banner will be charged extra		

1-Year (12 Issues)	₹ 300/-	Subscription Charges
2-Year (24 Issues)	₹ 550/-	
3-Year (36 Issues)	₹ 750/-	

Outstation payment should be at par cheque/DD drawn in favour of "Product News Publication" only

Trim Size: 28 [H] x 21 [W] cms; Bleed Size: 28.6 [H] x 21.6 [W] cms Material Requirement: CorelDraw or PDF Files



Editorial, Circulation & Marketing Office

Product News Publication

104, Sudama Yash, Nr: Ramkrishna Hotel, Kelkar Cross Road, Ram Nagar, Dombivli (E), Thane 421 201
 Mobile: 98206 70855 / 98208 38998 | E-mail: ipsmaginfo@gmail.com / ipsmag@yahoo.com

Visit: www.ips.co.in / www.industrialproductssource.com to view our e-magazine



Plastics Recycling Show India & UTECH India 2024 Concluded with Resounding Success

**PRSI & UTECH Returns for its 2nd Edition
from November 13-15, 2025, at Bombay Exhibition Centre, Mumbai**

The inaugural editions of Plastic Recycling Show India (PRSI) 2024 and UTECH India - Sustainable Polyurethane and Foam Expo (ISPUF) 2024, organized by Crain Communications and Media Fusion, concluded successfully last December, setting new benchmarks in sustainability, recycling, and material innovation. Both events brought together industry leaders, policymakers, and innovators to drive meaningful conversations and showcase groundbreaking solutions that will shape the future of their respective sectors.

PRSI 2024 witnessed over 6,000 visitors exploring the latest advancements in plastic recycling, sustainable materials, and waste management solutions from more than 120 exhibitors. The event featured a packed conference, with sessions addressing extended producer responsibility (EPR), advancements in recycling technology, waste segregation strategies, and regulatory frameworks. Moreover, the Plastics Recycling Awards India recognized excellence in the industry. The awards celebrated individuals and organizations driving innovation and sustainability in plastics recycling across 6 categories, including Ganesha Ecosphere Ltd., Pashupati Group, DOMO Engineering Plastics India, Ishitva Robotic Systems and Banyan Nation winning accolades.

Simultaneously, ISPUF 2024 - along with the Sleep Expo India Pavilion - served as a premier platform for the polyurethane and foam industry, attracting 2,700+ visitors and around 50 exhibitors presenting cutting-edge polyurethane and foam innovations. The event's knowledge-driven conference, featuring 18 expert speakers, covered key trends such as sustainable PU applications, advanced manufacturing processes, mattress manufacturing and regulatory developments.

Mr Taher Patrawala, Managing Director, Media Fusion, said, "PRSI & UTECH ISPUF 2024 have reaffirmed the pivotal role of strategic initiatives in driving sustainability and innovation across the plastic recycling, polyurethane, and foam industries. By uniting industry leaders, innovators, and policymakers, the event provided a dynamic platform for knowledge exchange, groundbreaking solutions, and collaborative efforts towards a circular

economy. The remarkable participation of over 8000 visitors and 160+ exhibitors highlight the industry's commitment to responsible waste management and sustainable material advancements. As these sectors continue to evolve, PRSI and ISPUF will remain instrumental in shaping industry standards, fostering innovation, and paving the way for a more sustainable future."

PRSI & UTECH ISPUF 2024 received robust support from leading industry associations, media partners, and advocacy groups committed to driving sustainable change in the plastics recycling sector. Key supporters included the Builders' Association of India, Association of Furniture Manufacturers and Traders, Indian Plastics Institute (IPI), and the Association of PET Recyclers Bharat (APR Bharat) amongst others.

Mr Matthew Barber, Global Events Director, Crain Communications said, "The overwhelming success of PRSI & UTECH ISPUF 2024 underscores the country's growing commitment to circular economy principles, sustainable product innovations, and global collaboration. With participation from 50+ countries, both events have reinforced their positions as premier platforms for business growth, knowledge sharing, and policy advancements. This global engagement highlights the increasing need for cross-industry cooperation and innovation-driven solutions to tackle sustainability challenges and shape the future of these industries."

Building on this momentum, Crain Communications and Media Fusion are excited to announce the second editions of both events, set to take place from November 13-15, 2025, at the Bombay Exhibition Centre, Mumbai. The upcoming editions promise expanded industry participation, deeper insights, and unparalleled networking opportunities, further driving innovation and sustainability in these critical sectors.

PRSI and ISPUF 2024 have successfully laid the foundation for a more responsible, efficient, and forward-thinking approach to material recycling and sustainable applications. As industries continue to evolve, these platforms will remain at the forefront, fostering collaboration and shaping the future of sustainability.

BGR Tech Ltd Partners with Stargate Hydrogen to Advance Green Hydrogen Production in India



BGR Tech Ltd., a Prenora Investment holding company in India, has entered into a strategic partnership with Stargate Hydrogen, an Estonian pioneer in Alkaline electrolyzer systems. The Memorandum of Understanding (MoU) was signed by Ms Priyadershini Raghupathy, Founder & Chairperson of BGR Tech, and Mr. Marko Virkebau, CEO & Board Member of Stargate Hydrogen.

This collaboration aims to bring Stargate's advanced high-pressure Alkaline Water Electrolyzer (AWE) technology to the Indian market. Stargate's flagship product, the Stellar Series AWE, operates at pressures up to 32 bar and offers a single stack capacity of up to 100 Nm³/h (500 kW). This design focuses on minimizing maintenance and operational costs, making it a practical solution for green hydrogen production.



The Stellar Series Alkaline Water Electrolyzer from Stargate Hydrogen, Estonia being unveiled by Her Excellency Ms Marje Luup, Ambassador of Estonia in India in the presence of Mr Marko Virkebau, CEO – Stargate Hydrogen and Ms Priyadershini Raghupathy, Founder and Chairperson–BGR Tech along with Mr Parthiban Selvaraj, Head Business Development–BGR Tech.

Stellar Series electrolyzer will be integrated into BGR Tech's pilot plant, which includes an Ultra-Pure water treatment unit, a Gas Separation Unit (GSU) and a Hydrogen Purification System (HPS). This integration is expected to enhance the efficiency and reliability of hydrogen production systems tailored for Indian projects. The BGR-Tech's inhouse Pilot plant in Chennai is expected to produce the Green Hydrogen by May 2025 and the same will be used a R&D tool for further monitoring & improving the reliability & efficiency of the system.

The Stellar Series Alkaline Water Electrolyzer stack was recently unveiled by Her Excellency Ms. Marje Luup,

Ambassador of Estonia to India during India Energy Week 2025 in New Delhi. This event highlighted the commitment of both companies to support India's growing energy needs through sustainable solutions.

This partnership aligns with India's National Green Hydrogen Mission, aiming to promote sustainable energy solutions and reduce carbon emissions. By combining their expertise, BGR Tech and Stargate Hydrogen are poised to make significant contributions to the advancement of green hydrogen infrastructure in India by exploring further possibilities for local manufacturing to support "Make in India" policy.



The Stellar Series Stack from Stargate Hydrogen launched at IEW 2025 by Her Excellency Ms Marje Luup, Ambassador of Estonia in India accompanied by Mr Vinod Basliyal, Chief FDI & Export Representative - Embassy of Estonia/ Estonia Business and Innovation Agency (En-terprise Estonia)

About BGR Tech Ltd:

BGR Tech Ltd., a Prenora Investment holding company based out of Chennai, India, brings rich engineering experience and technical prowess to the global energy sector. With expertise spanning a wide range of industries, from Oil and Gas Upstream applications to cutting-edge renewable energy solutions such as Green Hydrogen production systems, BGR Tech Ltd. stands at the forefront of complex energy requisites. The company's unique ability to cater to the ever-evolving demands of customers is a testament to its heritage and innovation. BGR Tech offers a plethora of options in terms of scalability and modular-based hydrogen purification systems.

As the energy industry transitions to sustainable and cleaner alternatives, BGR Tech Ltd. is well positioned to lead the way. The company's holistic approach — from concept to commissioning of next-generation renewable systems — enables them to cover every critical facet of the global energy market. Whether it's delivering high-performance systems for traditional energy sectors or pioneering the development of green hydrogen solutions, BGR Tech Ltd. is shaping the energy of the future.

Sugatsune Introduces Swivel Torque Hinge HG-S for Smooth 360-degree Rotation

Sugatsune, a global leader in premium hardware solutions, introduces the Swivel Torque Hinge HG-S, a perfect fusion of sophistication and cutting-edge engineering. The pensive design allows 360-degree rotational movement and resistance. Unlike standard hinges that permit unrestricted swinging of panels, the Swivel Torque Hinge HG-S integrates a specialized mechanism that imparts torque, allowing the lid or panel to maintain a fixed position once opened.

The Swivel Torque Hinge HG-S guarantees a unique design that ensures smooth, controlled movement, offering the remarkable capability to stop the lid in place at various angles. Featuring Motion Design Technology, it supports an advanced movement of free stop motion. The product is equipped with a central hole for effortless cable management. Notably, it has passed a rigorous 20,000 open or close private cycle test, ensuring long-lasting durability and reliability.

Sugatsune Swivel Torque Hinge HG-S is used in heavy machinery and industrial equipment to secure access lids and panels at the required angle for maintenance, while also providing precise control over large control panels in manufacturing plants, ensuring stability and easy access. It can be used in machinery, HMI units, or electrical enclosures, the swivel torque hinge allows for precise access while preventing the lid from swinging open or closing unexpectedly. These are used in heavy-duty machines to help lids open smoothly and stay in place at the desired angle during maintenance or operations.

Mr Anil Rana, Managing Director of Sugatsune India, said, “At Sugatsune, we are committed to pushing the boundaries of innovation and design. The Swivel Torque Hinge HG-S embodies our dedication to creating products that not only offer functional solutions but also enhance the overall user experience., we are setting new standards in versatility and performance for a wide range of industries and applications.”



The Sugatsune Swivel Torque Hinge HG-S is a game-changer for industries requiring precision and stability. Its ability to offer controlled movement, steady holding power, and versatile applications makes it the perfect solution for demanding environments. Whether in machinery or medical equipment, this innovative hinge sets a new benchmark for performance, ensuring that users can rely on it for both functionality and ease of use. At Sugatsune, we continue to innovate, delivering cutting-edge solutions that elevate industries and enhance everyday experiences.

About Sugatsune:

Founded in Japan in 1930, Sugatsune is a global leader in metal hardware manufacturing, known for its Japanese craftsmanship, precision engineering, and innovation. With over 20,000 products, including hinges, handles, locks, drawer slides, and pocket door systems, Sugatsune offers advanced hardware solutions for homes, offices, architectural, and industrial applications. The company's products are celebrated for their durability, minimal maintenance, and outstanding performance. In India, Sugatsune is committed to enhancing spaces with reliable, safety-focused solutions. With experience centres in Mumbai, Delhi, Chennai, Pune, and Bangalore, Sugatsune continues to grow its presence, providing tailored support through its expert sales and technical teams.

Visit: <https://global.sugatsune.com/in/en/>

Industrial Products Source July 2025

Industrial Automation, Instrumentation,

Testing & Measuring Instrument

HRV Global Life Sciences Strengthens Global Presence at DCAT Week 2025 in New York

HRV Global Life Sciences, a leading provider of innovative solutions for the pharmaceutical and life sciences industry, participated in DCAT Week 2025, the premier event for the global bio/pharmaceutical manufacturing value chain. Held in New York, the event brought together industry leaders, innovators, and decision-makers from around the world to discuss emerging trends, forge strategic partnerships, and drive advancements in pharmaceutical development and manufacturing.

Attending DCAT Week 2025 provided HRV Global Life Sciences' with a valuable platform to explore new business opportunities and forge new partnerships with US industry influencers. As one of the leaders in the virtual Pharma segment, the company is setting new benchmarks in the industry through its innovative approach to pharmaceutical manufacturing and distribution. The company has a pipeline of over 25 products to be launched in US and European markets in the current year.

India's pharmaceutical industry, valued at around USD 55 billion, is expected to grow 2.2 to 2.4 times over the next six years, reaching USD 120 billion to USD 130 billion by 2030. HRV Global Life Sciences is well-positioned to drive India's transition from a volume-based exporter to a leader in high-value products, reinforcing its position in the global pharmaceutical market.

Speaking on the participation, Mr Hari Kiran Chereddi, Managing Director of HRV Global Life Sciences, said, "DCAT Week 2025 provided an incredible platform for HRV Global Life Sciences to connect with industry leaders, exchange valuable insights, and strengthen our global partnerships. We had productive discussions on the evolving needs of the industry. We identified new opportunities for collaboration that will help drive innovation, facilitate global market expansion, and reinforce India's position as a key player in the international pharmaceu-



tical landscape.”

With India's pharmaceutical sector driving the country's economic growth, HRV Global Life Sciences is well-positioned to capitalize on this momentum. Its strong global network and focus on innovation enable the company to support this growth and meet the evolving needs of the pharmaceutical industry.

About HRV Global Life Sciences

HRV Global Life Sciences, established in 2015 and headquartered in Hyderabad, India, is a leading manufacturer and supplier of APIs, intermediates, and pharmaceutical additives. The company has a strong global presence with offices in the USA, Switzerland, Dubai, Lithuania, and Turkey, serving over 100 corporations worldwide. HRV partners with more than 55 Indian drug substance manufacturers, focusing on markets in Europe, the US, and the Middle East.

For more information, please contact:

Venkatesh J |6303374248 | Venkatesh@conceptpr.com

Industrial Products Source

June 2025

Foundry Equipment, Casting, Forging & Shot Blasting,
Boilers & Furnaces

Products INDEX

A		Car Parking Unit	c-i
AC Servo Motor Driven Pumps ASR Series	8	Cartonator Pockets	4
Acrylic Body Manometers	29	CCT / Cat-5 / LAN Cables	c-ii
Aerators	7	Centrifugal Chemical Process Pumps	24
Aerial Bunched Cables	c-ii	Centrifugal Monoblock Pump	38
Air Driven Liquid Pumps	35	Chain Hoist	c-i
Air Velocity Kit	13	Chain Pulley Block	c-i
All Kinds of Other Special Cables	c-ii	Chemical & Oil Guard Gloves	19
Alloy Steels	3	Chemical Plants & Process Equipments	23
Angle Seat Valves	15	Chemical Process Pump	7
Apron Feeders / Conveyors	c-iii	Chemical Process Pump PCPS Series	28
Automated Reference Method Sampler	c-iii	Chemical Sealed Gauges	11
Automation X20 Drives	34	Clamps for Photo Cells	4
B		Clear Water Pumps	42
Ball Valve with Actuator 3-Way 120°	17	Close Coupled Self-Priming NSA	
Ball Valve, 3-Piece Flanged End	36	Centrifugal Pump	16
Ball Valves	36	Co-Axial / Instrumentation / Computer Cables	c-ii
Barometer	13	Coiled & Disc Springs	3
Belt Conveyors	c-iii	Cold Work Tool Steels	3
Belt Conveyors, Pipe Conveyors	c-iii	Commercial Gauges	11
Belt Tumbler (Tumblast) Type Shot		Compact Sealed Gauges	11
Blasting Machine	7	Comparison Tester	11
Bi-Metallic Temperature Gauges	11	Conditional Monitoring Systems	c-i
Bipod	4	Conductivity Level Switches	13
Blast Room and Paint Room System for		Cone Crusher	c-iii
Paper Industries Machine Manufacturers	c-i	Construction Electric Hoists (Modular)	5
Brackets & Guides	4	Control Cables	6
Breather Valves	41	Control Valve Diaphragms	18
Brute Force Screen	c-iii	Conveyors & Components	4
Bucket Elevators	c-iii	Crane Kits and Components	c-i
Butterfly Valves	30, 31 & 37	Crane Kits	c-i
By-Pass Rotameter	13	Cranes & Hoists	c-i
C		Cranes (Eot, Goliath, Flameproof)	5
Cable Drag Chain	c-i	Crude Oil Start Up/Dispatch (COD) Pumps	21
Cables & Wires	c-ii	D	
Capacitance Type Level Transmitters	13	Diaphragm Seated SS Metal Body Valves	38

Die Steels	3	Gate Valves	42
Digital Pressure Gauges + Transmitter	19	Gauge Saver	11
Digital Pressure Gauges	13	Glass Tube/Acrylic Rotameters	13
Digital Pressure Switches	13	Globe 3 Way Control Valves (Series 130)	27
Direct Gauges	10	Globe Valves	17
Disc Springs	23	Goliath Cranes	c-i, 5 & 13
Dock Leveler	c-i	Goliath/Gantry Cranes	9
Double Girder EOT Cranes	c-i	Goods Lift	c-i
Double Stage Water-Ring Vacuum Pumps	16	Grab Buckets	5
Dynamic Sealing Pump	20	H	
E		HD RH Series Hidamp RH Series	26
Economical Gauges	11	Heat Transfer Fluid	4
Electric Actuated Butterfly Valve	37	Heavy Duty Bucket Elevator	c-iii
Electric Chain Hoist	c-i	Heavy Fabrication with Machining	c-i
Electric Wire Rope Hoists	5	High Frequency Screen	c-iii
Electromagnetic Flowmeter	13	High Vacuum System	33
EOT Cranes	5 & 27	Hoists	5
F		Homogenizer Gauges	11
Files	29	Hook-up Wires	c-ii
Five Valve Manifold (T) Type	16	Horizontal Chemical Process Pump / Semi-Open Impeller Process Pump	18
Flame Proof Cranes	5	Horizontal Pumps	33
Flat Submersible Cables (3 Core)	c-ii & 19	Hot Work Tool Steels	3
Flexible / Industrial Cables	c-ii	House Wiring / Multicore Cables	c-ii
Float & Board Level Indicators	c-i	Hydraulic & Pneumatic Products	28
Floor Handling Equipments	c-i	Hydraulic Bending Press	40
Flow Indicators	c-i	Hydraulic Products	30 & 36
Flow Switches	13 & 35	I	
Forged Steel Valves	32	Idlers, Rollers & Pulleys	c-iii
Forging Components	3	Impact Hammer Crusher	c-iii
FR / FRLS / PVC Cables (HT & LT Cables)	c-ii	Impact Sockets	3 & 34
Free Standing Structures with Cranes	c-i	Industrial Burners	4
FRP Underground Storage Tank	25	Industrial Dual Block Burners	4
Fundacart PP Pleated Cartridges	39	Industrial Gauges	11
G		Industrial Valves	23 & 24
Gantry Crane	c-i	J	
Gas/Heavy Oil Burners	4	Jacketed Casing Pump	11
Gas/Light Oil Burners	4	Jib Cranes c-i & 10	
Gate Valve API 6D	12		

K		O	
Kitz Butterfly Valves	42	Oil Free Rotary Vane Vacuum Pumps	26
L		Oil Free Vacuum Pumps cum Compressor	16
LAN Cables	c-ii	Oil Sealed Rotary High Vacuum Pump	11
Level Instruments	c-i	Oil/Gas/Dual Fuel Burners	4
Lined Globe Control Valve	31	Organic Acid Based Degreasing Chemical	10
Lined Valves	14	ORION Dry Vacuum Pump	32
Lining Products	37	P	
Liquid Column Manometers	13	Peripheral Turbine Mag Drive Pumps	8
Liquid Level Indicators	13	PFA/Antistatic PFA/FEP/PVDF/PP HDPE Lined	
Liquid Level Switches (Float Operated)	13	Pipe Fittings	10
Liquid Level Transmitter	13	Pipe Conveyors	c-iii & 29
Liquid Ring Vacuum Pump / Compressor VWS Series	6	Pipe, Tubes, Fittings & Flanges	32
Liquid Ring Vacuum Pumps & Compressors		Plastic Mould Steels	3
for Thermal Power Plants	6	Platen Type Hydraulic Screen Changer	8
Liquid Ring Vacuum Pumps	7	Pneumatic Actuators	15
Low Pressure Capsule Gauges	11	Pneumatic Cylinders T Series – Round	
LT & HT Panel	20	Barrel Cylinders	15
LT/LV Cables	20	Pneumatic FFS Machine – Weigh Filler	22
M		Pneumatic Products	13, 14 & 33
Magnetic Float Switch	18	Pollution Control Equipment	7
Magnetic Level Indicators	c-i	Porosil - Revolutionary Fusion Process	39
Manometers	c-i	Portable Gentry Crane	c-i
Material Handling Equipments	c-i	Power & Control Cables (Aluminium / Copper /	
Measuring Instruments	13	Conductor / Armoured Unarmoured Cables)	c-ii
Mechanical Tilters / Lifting Beams	c-i	Power Cables	12
Metal Tube Rotameter with Transmitter /		Preservation Line Inline Blasting, Painting	
Flow Indicator Totalizer	13	and Baking System	c-i
Modular Supports	4	Pressure Booster Pumps, SCM Series	34
Mono Rail Trolley	c-i	Pressure Boosting Pump	5
Moulded Plugs	c-ii	Pressure Gauges	11
Mud Gauges	11	Pressure Reducing Valve	24 & 32
Multi-Stage High Pressure Air		Pressure Switches	13
Cooled Compressors	18	Process Equipment	36
N		Process Instruments	13
Needle Valves	11	Process Pumps EO/EOS Series	31
New Generation Hoist	c-i	Pulse Jet Bag Filter	c-iii
NOP Filter Pumps	26	Pump for Corrosive & Abrasive Fluid Services	25

Push Button Safety Quick Release Coupling	40	Single Girder EOT Cranes	c-i
PVC Insulated Industrial Wires & Cables	c-ii	Single Step Pickling Passivation Product for SS and its alloys	33
R			
Reflex & Tubular Level Gauges	c-i	Single Toggle Jaw Crusher	c-iii
Reflex Transparent Boiler Gauges	c-i	Single Valve Gate	14
Resonance Screen	c-iii	Solar Cables	c-ii
Reverse Pulse Jet Bag House Dust Collectors	12	Solenoid Operated Interlocking Device	21
Reversible Hammer Crusher	8	Special Blasting Machine for Roof-Mounted Pantographs Contact Strips of Electric Rail	c-i
Roots Blower	7	Special Pressure Blaster Machine for Roll Etching	c-i
Roots Vacuum Pumps	22	Special Shot Blasting Machine for Cleaning of Submersible Pump Casing	c-i
Rotary Airlock Valve	40	Special Shot Blasting Machine for Fold-away Tray of Sheet Molding Compound	c-i
Rotary Gear Pump	c-iv	Split Case Fire Pumpset Horizontal	20
Rotary Gear Pump, Type HGSX	41	Split Case Pumps ASP Series	17
Rotary Gear SS Pump	c-iv	Spring Steels	3
Rotary Jacketed Pump	c-iv	Springs & Wire-formed Products	37
Rotary Main Oil Pump	c-iv	Square & Round Bars	3
Rotary Monoblock Pump	c-iv	SS Hydraulic & Instrumentation Tubes	21
Rotary Tracodial Pump	c-iv	SS Welded Pipes	21
Rotary Triple Twin Gear Pump	c-iv	Stainless Steel and Cast Iron Pumps	31
Rotary Triple Twin Gear Pump Type NDX Series	29	Stainless Steel High Pressure Pneumatic Solenoid Valve	26
Rotary Twin Gear Pump	c-iv	Steam Jacketed Kettle	28
Rotary Twin Gear Pump, Type RDRN	9	Submerged Sump Pumps for High Temperatures	40
Rotary Valve	19	Submersible Portable Pumps, PST Series	42
Rubber Tyre Gantry Crane	c-i	Submersible Sewage Pumps	35
S		Submersible Vortex Sewage Pumps	
Samples & Sampling Systems	c-iii	PSNC/PSNCV Series	5
Scissor Platform	c-i	Sucking Blower	28
Scissors Lift	c-i	Surface Finishing Solution	c-i
Screw Conveyors	c-iii & 27	Switches	c-i
Seamless SS Pipes & Tubes	35	Synthetic Heat Transfer Fluid	4
Semi Electric Stacker	c-i	Synthetic Heat Transfer Fluid, Maxothermie-550STM	9
Shear Beam Load Cell & Mounting Assembly	22	Syphons	11
Shrouded DSL System	c-i	T	
Sidewall High Angle Conveyor	c-iii	TC Rollers for Hot & Cold Rolling Mills	13
Siemens Process Instruments	c-i		
Sight Flow Indicator	27		
Sight Glasses	c-i		
Single Cone Vacuum Pump	7		

Telecommunication Cables	`c-ii	Turbine Inlet Valve	30
Temperature Gauges	11	U	
Temperature Measuring Instruments & Allied Products	13	Unique Aluminum Labels for Pharmaceutical Plants	38
Testing Equipments & Accessories	11	V	
Thermal Relief Valve	30	Vacuum Manometer	13
Thermoplastic Valves	14	Vacuum Nutsch Filter	22
Three Core Flat Submersible Cables	c-ii	Vacuum Pumps	7 & 39
Tool & Alloy-Special Steels	3	Vacuum Pumps and Systems for Power Plants	24
Tools – Collets	3	Vacuum Systems	15
Torque Flow Pumps	6	Vertical Pumps	25
Traction Alternator C1009TA	25	Vertical Shaft Impactor	c-iii
Transfer Trolley	c-i	Vibrating Feeder	c-iii
Transformer Oil Pumps	39	Vibrating Grizzly Feeder	c-iii
Transmitters	c-i	W	
Triclover Sealed Gauges	11	Wafer Check Valves	17
Triple Offset Butterfly Control Valve Series 47000	23	Water Ring Vacuum Pumps	7
Tripod	4	Wheels-Rollers for Sliding	c-i
TRS / TRS Braided / Welding Cables	c-ii	Winches	c-i & 5
Truck Loader and Unloader	c-i	Wire Rod	3
		Wire Rope Hoist	c-i

A D V E R T I S E R S ' I N D E X

A		Mec Shot Blasting Equipments Pvt Ltd	c-i
Arbuda Instruments	11	Moldex Corporation	4
D		N	
Del Pd Pumps & Gears (P) Ltd	c-iv	Nirmal Energy Limited	4
E		P	
Elmech Engineers	5	PPI Systems	7
Empire Cable Industries Pvt Ltd	c-ii	R	
Environ Engineering Company	7	R. K. Dutt Concerns	c-i
F		T	
Fitzer Instruments Company (India)	13	Tacklers Engineering Private Limited	c-i
M		V	
Masyc Projects Pvt Ltd	c-iii	Ventura Alloy and Steels Private Limited	3

BULK MATERIAL HANDLING SYSTEMS PRODUCT RANGE



PIPE CONVEYORS



PULSE JET
BAG FILTER



IMPACT HAMMER
CRUSHER



VIBRATING GRIZZLY
FEEDER / VIBRATING
FEEDER



BELT CONVEYORS



AUTOMATED REFERENCE
METHOD SAMPLER



RESONANCE
SCREEN



BRUTE FORCE
SCREEN



HIGH FREQUENCY
SCREEN

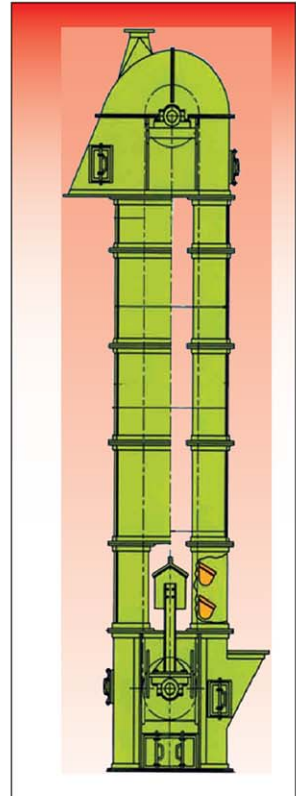

HEAVY DUTY
BUCKET ELEVATOR

Quality Policy

To be Customer's Delight and achieve all round excellence.
To Strive for continuous improvement in business performance through
Commitment of all Employees.

Bulk Material Handling Systems



MASYC

AN ISO 9001 : 2008 CERTIFIED COMPANY



MASYC PROJECTS PVT. LTD.

23, Community Centre, Mayapuri Phase-1, New Delhi 110 064 (INDIA)

Tel: 11 2811 5745, 2811 5453, 2811 3383

E-mail: masyc@masycproject.com, Website: masycproject.com

We Also Undertake Turnkey Execution of Cement Grinding Units

So Ask For, Go For & Insist For World Class



Rotary Gear, Twin Gear, Triple Twin Gear Pump

We Generate Electric Power Through our Gear Pump Business.
Strange & Surprising ! but a Proven Fact
Since Power Saved is Electricity Generated

<p>Type ET</p>  <p>Rotary Trocodel Pump From 1/8" To 2 1/2" NPT 10 LPM To 350 LPM Pressure upto 8 kg/cm² App: Fuel oil, Lube oil, Eng. oil.</p>	<p>Type RDNR / RDRX</p>  <p>Rotary Twin Gear Pump From 1/2" to 6" NB (Ranged to ASA 150 Class) Capacity upto 200 M³/hr Pressure upto 11 kg/cm² App: FO, LO, HSD, LDO, Crude oil, HFO, LSH, etc.</p>	<p>Type RDMS All SS</p>  <p>Rotary Gear Pump From 1/8" To 1.50" NB Cap 0.5 M³/hr To 120 M³/hr Pressure upto 15 kg/cm² App: Foam, Chemicals, Paints, Varnish, molaris, Resin, Soap solution.</p>	<p>Type SPN</p>  <p>Rotary Gear Pump From 1.5" NB To 5" NB Cap 5 LPM To 225 LPM Pressure upto 20 kg/cm² App: Lube oil, Fuel oil, Hyd oil, Turbine oil.</p>	<p>Type RDRBJ</p>  <p>Rotary Jacketed Pump From 1.5" NB To 1.50" NB Cap Upto 200 M³/hr Pressure upto 11 kg/cm² App: Bitume, Tar, Asphalt, Sicatite, Wax, Grease.</p>
<p>Type HGMX</p>  <p>Rotary Gear Pump From 1/8" To 2 1/2" NPT 5.0 LPM To 350 LPM Pressure upto 10 kg/cm² App: Oil, Castor oil, Gear oil, Resin, etc.</p>	<p>Type HGXC</p>  <p>Rotary Monoblock Pump Lube oil priming & Filling pump. Size from 1/2" To 1" BSP Flow upto 40 LPM Pressure upto 7 kg/cm² App: LO, Base oil, Hyd oil, Turbine oil.</p>	<p>Type HGXS All SS</p>  <p>Rotary Gear SS Pump From 1/8" To 2 1/2" NPT Flow From 5.0 LPM To 350 LPM, Pressure upto 10 kg/cm² App: Glycerine, DYE, Glucose, Sugar syrup, Cream, Glue, Glycol.</p>	<p>Type NDX</p>  <p>Rotary Triple Twin Gear Pump Size From 5" To 12" NB Cap : 80M³/hr To 550 M³/hr Pressure upto 11 kg/cm² App: Bulk cargo load/UL, Fuel oil, LO, Crude oil, HSD, LDO, Gas oil, etc.</p>	<p>Type RDRBF</p>  <p>Rotary Main Oil Pump From 1.5" NB To 1.50" NB Cap Upto 200 M³/hr Pressure upto 11 kg/cm² App: Lube oil, Turbine oil, Hyd oil, Engine oil.</p>
<p>Type RDBX RDNX</p>  <p>Rotary Gear Pump From 1/2" To 6" Size Flow upto 125 M³/hr Pressure upto 21 kg/cm² App: Lube oil, Fuel oil, LSH, Napalm, IRS.</p>	<p>Type HGBX</p>  <p>Rotary Gear Pump Size From 1/4" To 2 1/2" BSP Capacity From 2.5 LPM To 400 LPM Pressure upto 10 kg/cm² App: FO, LSH, LO, HFO, Tran oil.</p>			

APPROVED BY : EIL,UHDE,DALAL,AKER,TOYO,TECHNIMONT,LURGI,TECHNIP,DGGA,DLW,DMW,BVQI,DNV,IRS,ABS,LLOYDS,MOODY.

Del Pd Pumps & Gears (P) Ltd.

113,G.I.D.C., Estate, Wadhwan-363035 SurendraNagar, Gujarat (India)
Phone :+91-2752-243047 / 243678 / 241223 Fax : 91-2752-243744
Email : rotodel_ad1@sancharnet.in , sales@delpump.com
Website : www.delpump.com



ISO 9001:2008
CERTIFIED