

Industrial Products Source

ISSN 0973-1857

A Magazine for Indian Industries

Vol 18

Issue 3 March 2021

₹ 30/-

A Product News Publication

Total no. of pages 60

Visit: www.ips.co.in
to view our e-magazine

Focus:
Machine Tools,
Auto Components & Accessories

Products Index
Page 54

BALL TRANSFER UNITS

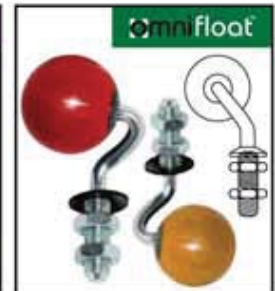

AMCATS PVT. LTD.

Advanced Motion Control & Automation Systems

303-308, Krishna Bhuvan Annex B, 22-B, Govandi Station Road, Deonar, Mumbai 400 088

Tel.: 022 - 6146 4444 • Fax: 022 - 6146 4499 • E-mail: sales@amcats.com • URL: www.amcats.com



ESTD. 1945

SOLAR Pump Controller - Variable Frequency Drive (VFD)
with Maximum Power Point Tracking (MPPT) Control

invt GD100-PV & BPD
& SPC Series **POWERMAG**



- Pump RUN with solar power • MPPT Advantage :
Water supply at various solar energy levels • Water
flow throughout the day • Suitable for all types of
water pumps - Single phase 230 V AC, 3 phase
415 V AC, 3 phase 230 V AC 50 / 60 Hz
- Works with existing pumps

- No need of electricity supply •

Authorised Sales & Service:

POWERMAG CONTROL SYSTEMS PVT. LTD.

SF No:532, Nehru Nagar, Maniakanpalayam, Ganapathy
Coimbatore - 641 006, Tamilnadu, India.

Tel.: 0422 253 2013, 253 7990 • Fax: 0422 253 7988

Cell: 092444 07258 • E-mail: powermag.india@gmail.com

Website: www.powermag.in

TRUSTED SERVICE SINCE 1993

**KADKRAFT
SYSTEMS**

**SMARTTECH 3D
METROLOGY**

*Highest Resolution 3D Scanners
in the world!*

Reverse Engineering

*Automated Quality
Inspection*



Kadkraft Systems Pvt. Ltd.
D-133B, Phase VII,
Industrial Area,
Mohali - 160055,
Punjab.
90231 72022
www.kadkraft.com



- ◆ Long Lasting Accuracies
- ◆ Immense Chucking Power
- ◆ Minimum operator Fatigue
- ◆ High productivity



Power chucks, Chuck Spares, Base Jaws, Soft Jaws and Hard Jaws manufactured in both Standard and Special sizes in 2, 3, 4, 5, 6, 8 and 12 jaw type chucks upto 800mm diameter.

Hard Jaws



Soft Jaws



An ISO 9001:2015 Certified Company

We also manufacture - Air / Hydro / Rotary Power Chuck, Preci[®] Chuck, Jaws Eccentric Compensating Chuck (JPCE), Built-in Cylinder Collet Chucks, Base Jaws, Chucks Spares, Special Chucks and Jaws, Hydraulic/Pneumatic Rotary Cylinder, Jaws Boring Rings

www.jawsindia.com



JAYESH ENTERPRISES

**Measuring Technology
on the Right Track**

Taper Gauges



These gauges are manufacture as per customer drawing/requirements.

Gauges Inspected In **NABL** Certified
ISO 17025 : 2017 Laboratory

**Plain
Plug Gauges**



**Thread
Gauges**



Ring Gauges



An ISO 9001:2015 Certified Company

We also manufacture - Special Gauges, Carbide Gauges, Plain And Adjustable Snap Gauges, Key Way Width Gauges, Slip Gauges / Gauge Blocks (Loose)

www.gauges.co.in

103, Ramtekdi Industrial Estate,
Hadapsar, Pune 411 013 Maharashtra (INDIA)
Tel : + 91 91 588 66 112 / 91 588 66 113 / 91 588 66 114
Email : jawssales@jawsindia.com

Bulk Material Handling Systems Product Range



BELT CONVEYORS

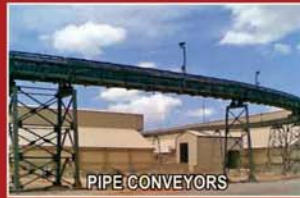

PIPE CONVEYORS



PULSE JET BAG FILTER



VERTICAL SHAFT IMPACTOR



SINGLE TOGGLE JAW CRUSHER



CONE CRUSHER



VIBRATING GRIZZLY FEEDER /
VIBRATING FEEDER



RESONANCE SCREEN



BRUTE FORCE SCREEN



IMPACT HAMMER CRUSHER



AUTOMATED REFERENCE
METHOD SAMPLER



HIGH-FREQUENCY SCREEN

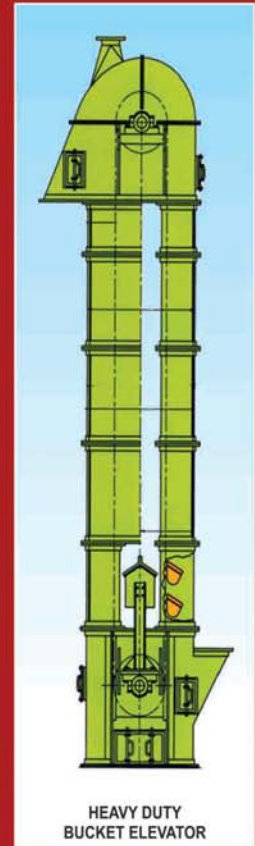

HEAVY DUTY
BUCKET ELEVATOR

We Also Undertake Turnkey Execution of
Cement Grinding Units

Quality Policy

*To be customer's delight and achieve allround excellence.
To strive for continuous improvement in business performance
through commitment of all employees.*



MASYC
ISO 9001 : 2008 CERTIFIED CO



ISO 9001:2008



United Accreditation System of
Australia and New Zealand

MASYC PROJECTS PVT. LTD.

23, Community Centre, Mayapuri, Phase-I, New Delhi-110064
Tel : +91-11-2811 5453, 2811 5745, 2811 3383 Fax : +91-11-2811 6850
E-mail: masyc@masycproject.com Website : www.masycproject.com

Industrial Products Source

(A Product News Publication)

Vol. 18 No. 3 March 2021

Editor & Publisher: Mohanan N
Mobile: 098206 70855

Sub Editor: Ramachandran. T
✉: ipseditor@gmail.com

Marketing Manager: V Madanmohan
Mobile: 098208 38998

Layout Artist: Prashant Kumar K

Single copy price: ₹30/-

Annual Subscription: ₹300/-

Regd Office

A/10 Jayshree Laxmi Puja CHS, Plot No: 78/82
Ramachandra Nagar, Dombivli (E), Thane 421 201

Editorial, Marketing & Advertising

104 Sudama Yash
Nr: Ramkrishna Hotel, Kelkar Cross Road, Ram Nagar,
Dombivli (E), Thane 421 201
☎ 0251 – 2861 351

✉: ipsmaginfo@gmail.com/ipsmag@yahoo.com

Representatives

Coimbatore: Rajeev Kumar, Mobile: 094431 29073

Industrial Products Source is a product news monthly publication, registered with the Registrar of Newspapers for India, under No: MAHENG/2004/12919.

Industrial Products Source reserves the right to use the information published herein in any manner whatsoever. The Editor/Publisher to the best of their ability have tried to check the accuracy of information published in this issue which is based on the material supplied by respective manufacturers/agents/advertising agencies.

Neither **Product News Publication** nor any of its employees will be morally or legally responsible for any errors or omission. No part of this publication may be reproduced in any form without the written permission of the publisher. All rights reserved.

Printed and Published by Mohanan N on behalf of **Product News Publication** and printed at Perfect Prints, 22/23 Jyothi Industrial Estate Noori Baba Darga Road, Near Makhmali Talao Thane 400 601, and published from A/10 Jayshree Laxmi Puja CHS, Plot No: 78/82 Ramachandra Nagar, Dombivli (E), Dist: Thane 421 201.

Editor: Mohanan N

CONVEYORS & COMPONENTS



A WIDE RANGE TO CHOOSE

- Slats in Delrin, S.S., M.S
- Multi Directional
- Universal Flex
- Stackable
- Min / Backline Force
- Nylon, MS, SS Sprockets
- Brackets + Guides
- Clamps for Photo Cells
- Cartonator Pockets
- Tripod & Bipod
- Modular Supports

 **moldex corporation**

A-9, New Empire Industrial Estate, Kondivita Road, J.B.Nagar,
Andheri (E), Mumbai 400 059
Phone: 022 - 2821 5068 / 2830 0618 • Fax: 022 - 2837 7088
Email: info@moldex.in / krish@moldex.in
Website: www.moldex.in

baltur INDUSTRIAL BURNERS

Bring to you by: **NIRMAL ENERGY LTD., AHMEDABAD** Authorised & Exclusive Rep. for INDIAN sub-continent:



Oil / Gas / Dual Fuel Burners

- Baltur S.p.A., Italy for its Energy Efficient, High Technology, Oil/Gas/Dual Fuel Burners;
- Capacity ranging from 16.6 KW to 44650 KW
- Retrofitting of Heating Equipment, Gas Train components, Ring Main systems
- Heat Exchangers & Custom Built Equipment, Heat Transfer Equipment & Accessories
- Light Oil Burners • Gas Burners • Heavy Oil Burners
- Dual Fuel • Gas/Light Oil Burners • Gas/Heavy Oil Burners



New Generation Burners.....TBG series

- Low NOx and Low CO emission class III defined according to standard EN 676:2000
- Excellent Quality / Price Ratio
- Many different version/executions like single stage (TBG) two stage (TBG.P) Pneumatic modulation (TBG.PN) Electronic modulations (TBG.ME), VFD inverter systems, Electronic and Digital Burner Management systems and more....



Industrial Dual Block Burners: IB / TS & IBR SERIES:

- Fuel: Gas, Light Oil, Heavy Oil and Dual Fuel, Pre-heated air burners
- IB/TS Series up to 17.5 MW and IBR Series up to 44.65 MW



NIRMAL ENERGY LIMITED (An ISO 9001:2015 Certified Company)

Corporate Office: 402, ISCON Elegance, Nr. Jain Temple, Prahladnagar Cross Roads, S.G. Highway, Ahmedabad 380 015, Gujarat • Tel: 079-6616 8944 • Telefax: 079-6616 8945
E-mail: info@nirmalenergy.com / salesadmin@nirmalenergy.com / burnersales@nirmalenergy.com

Services & Projects Support Office: **NIRMAL ENERGY LIMITED / NIRMAL ENERGY ENCON SERVICES**

CUJ14-15, Swelling Complex, Jodhpur Village Road, Satellite, Ahmedabad 380 015, Gujarat
Tel: 079-2892 3170 / 2892 23151 • Fax: 079-2692 3469 • Mobile: 99789 14903 / 98258 04925
E-mail: info@nirmalenergy.com / nirmalenergy@nirmalenergy.com / service@nirmalenergy.com

Website: www.nirmalenergy.com

AHMEDABAD : Mr. Shankar Pillai / Mr. Ujas Bhavsar	Cell No. 9978984504 / 9825804925
BANGALORE : Mr. B. S. Penumal	Cell No. 98403 83736
CHENNAI : Mr. B. S. Penumal	Cell No. 98403 83736
DELHI : Mr. Arvind Modgil	Cell No. 98258 04923
INDORE : Mr. Tarun Dhoundiyal	Cell No. 93000 77718
KOLKATA : Mr. Krishnendu Ghosh	Cell No. 94330 18350
MUMBAI : Mr. Arvind Modgil	Cell No. 98258 04923 / 099789 84503
PUNE : Mr. Abhiji Bhoskar	Cell No. 70301 10839



Dealership Enquiries are Solicited From Unrepresented Areas



We are Importer, Exporter, Stockist, Distributor & Suppliers for Tool & Alloy - Special and Die Steels, Forging Components Spring Steel - Wire Rod, Square & Round Bars Coiled & Disc Springs, Tools Collets, Impact Sockets Etc.



**HOT WORK
TOOL STEELS**



**COLD WORK
TOOL STEELS**



PLASTIC MOULD STEELS



ALLOY STEELS



SPRING STEELS

HOT WORK STEEL (IND/USA/EUR)

DB6 / AISI L6 / DIN2714
H13 / AISI H13 / DIN 2344
H11 / AISI H11 / DIN 2343
H21 / AISI H21 / DIN 2581
H10 / AISI H10 / DIN 2365
H12 / AISI H12 / DIN 2606

COLD WORK STEEL (IND/USA/EUR)

HCHCR-D2/AISI D2/DIN 2379 | A2/AISI A2/DIN 2363
HCHCR-D3/AISI D3/DIN 2080 | O1/AISI O1/DIN 2510
D5/ Cr12MoV/DIN 2601

PLASTIC MOULD STEEL (IND/USA/EUR)

P20+Ni/AISI P20+Ni/DIN 2738
P20/AISI P20/DIN 2311

ALLOY STEEL (IND/USA/EUR)

EN24/AISI 4340/40NiCrMo84 / 34CrNiMo6
EN19/AISI 4140/ 42CrMo4
EN31/AISI 52100/100Cr6

SPRING STEEL

EN47 / 50CrV4 / 51CrV4 / AISI 6150 / SUP10 / DIN 8159
SUP9 / AISI 5155 / DIN 1.7176
SAE 9254 / AISI 9254

Head Office

Unit No. 1201 & 1202, Ghanshyam Enclave P. Co-Op. Soc. Ltd,
New Link Road, Near Laljipada Police Station,
Kandivall West, Mumbai - 400067.
Tel.: +91 22 2869 3824 / 9324959833 Mob.: 7977097657

Stocking/ Machining Centre

Gala No. 6, Building No. 183, Indian Corporation, Mouje Gundavli
(Mankoli - Phata) Dapoda, Taluka - Bhiwandi : 421302
Tel : +91 7977097655 |
Email: sales@venturasteels.com | Web: www.venturasteels.com

SOVEREIGN SOLUTIONS FOR ALLOY, SPRING AND DIE STEELS

Metal and Non-Metal Laser Cutting Machine

Kheizer Sign offers Metal and Non Metal Laser Cutting Machine Model K-1325. It is a brand-new machine, which can cut thin metal, acrylic, wood and other non-metals. So it is a cutting machine for both metal and non-metal. With low investment, low running cost, low maintenance, the machine is the most economical and cost-effective metal and non-metal laser cutting machine for the market. Advantages: Stable stepper motor/Servo Motor – Japan Panasonic; Imported lead screw/Imported steel strip belt; With high accuracy of 3 M/5M conveyor; Can be a good match with AutoCAD, CorelDraw, Photoshop, Illustrator; It adopts the best DSP controller with USB disc transmission or computer for output. Technical Parameter – Work table size: 1300 x 2500 mm; Laser power: 130 W/150 W/200 W; Precision: 0.05 mm; Cutting thickness: 25 mm Acrylic; 1.0 mm stainless steel; Work voltage: AC 220 V/50-60 Hz.



Contact:

Kheizer Sign
 401 Aagman Complex, Mayur Colony
 Mithakhali, Ahmedabad, Gujarat 380 009
 ☎ 079 – 2643 1388 • Mob: 94260 77308
 E-mail: kheizer@live.in

CNC Router Machine

Mengi Engineering Company offers CNC Router Machines. Specifications of SM 6090 Power – Work table size: 600 mm x 900 mm x 120 mm; Table: T-slot combined table; Frame: Cast Iron; X, Y, Z Drive system: X, Y, Z ball screw; Max Rapid: 20 m/min; Max working speed: 15 m/min; Positioning accuracy: ±0.05 mm; Working accuracy: ±0.1 mm/300 mm; Spindle power: 3.5 kW; Spindle rotary speed: 24000 RPM; Power motor: Stepper motor; Voltage: AC 380 V, 50/Hz, 3 HP; Command language: G code; Control: DSP hand shank; Software: ART-CAM; Weight: 900 kg; Max travel speed: 15000 mm/min; Max working speed: 10000 mm/min; Working precision: 0.05 mm; Repeatability precision: 0.01 mm.



Contact:

Mengi Engineering Company
 Plot No: A/232, Road No: 21, Y Lane
 Wagle Estate, Thane 400 604
 ☎ 022 – 2582 3203 • Mob: 97699 76747
 E-mail: audatechindia@gmail.com



AN ISO 9001-2015
AND CE CERTIFIED COMPANY



CRANE CONTROL EQUIPMENTS

 Electro Hydraulic Thrustor Brake	 Electro Hydraulic Thrustor	 Resistance Box	 Rotary Limit Switch	 Gravity Limit Switch	 Lever Limit Switch
 Master Controller	 Multi Wire Cable Trolley	 Flexible Geared Coupling	 Insulated Conductor Bar	 Radio Remote Control	 Crane Automation
 Wire Rope Load Cell	 Pin type Load Cell	 Safeload Controller	 Armchair	 Crane Scale	 Anti-collision Device

We are a national level company manufacturing & supplying for THIRTY THREE YEARS to OEMs & user/govt depts. Complete range of control gear for EOT Cranes such as Lever Limit Switches, Counter Weight Limit Switches, Rotary Geared Limit Switches, Differential Limit Switches, Master Controllers, Pendant Push Button Stations [IP – 65] , Electro Hydraulic Thruster Brakes, Electro Hydraulic Thrusters, Electro Magnetic Brakes, S S Punched Grid Resistance boxes, Radio Remote Control, Shrouded Bus Bar System, C – Track Flexible Trailing System, Flexible Geared Couplings, Brake Drum Couplings, Cable Trolleys, Cable Reeling Drums, Gear Boxes, Crane Wheels, Digital Crane Scales, Load Cells, Anti-Collision Devices, Arm Chairs etc.

**DEALERS ENQUIRY
SOLICITED**

CRANE CONTROL EQUIPMENTS

Office & Works: B-249, Okhla Industries Area, Phase - I, New Delhi - 110 020.
 Tel: 011-41016403 to 405 # Mobile : +91 9810009466, 9310009466
 Email: info@cranecontrolequipments.com/sales@cranecontrolequipments.com
 www.cranecontrolequipments.com / www.cranecontrolequipments.net

Craftsman Motion

Division of Craftsman Automation Limited



Craftsman
motion

Product Range

- High Precision Case Hardened and Profile ground Gears
- Max.Diameter: 1000mm / Max. module: 16
- Worm and Worm wheel CD upto 10", Ratio 20:1 and above
- Single screw and Twin screw extruder gear boxes
- Hollow shaft Helical gear boxes for crane LT, CT & Hoist drive
- Multi crowned Gear coupling
- Helical gear boxes - Single, Two stage, Triple stage & Quadruple stage upto Centre distance (Last Stage) - 500mm
- Custom build Gear Boxes
- Geared motors



For enquiries
motion@craftsmanautomation.com
Mobile: +91 99439 87015

CRAFTSMAN AUTOMATION LIMITED

123/4, Sangothipalayam road,
Arasur Post, Coimbatore - 641 407
Tamilnadu, India
Tel: +91 422 30 510 00
Fax: +91 422 30 512 25



Built-in Cylinder Power Collet Chucks

The Jaws Manufacturing Co introduces its latest product – Air/Hydro Rotary Power Chucks with built-in cylinder. The Power Chuck is specially designed to help users to set up a power workholding system in a low cost way. With a built-in cylinder, it allows users to easily and quickly set up a power work-holding system. The system saves the cost of cylinder mounting flanges, draw bar/tube and connector. This Power Chuck also has quick-change jaw/collet design, helping you to cope with parts of various dimensions. The Power Chuck comes with both air and hydraulic models that range from small sizes to large ones, giving users more options to choose from. It can be applied to convert manual lathes to semi-auto ones with power workholding system, or can be applied to build all kinds of special purpose machines.



Contact:

The Jaws Manufacturing Co
103 Ramtekdi Industrial Estate, Hadapsar
Pune, Maharashtra 411 013
Mob: 91588 66112, 91588 66113, 91588 66114
E-mail: jawssales@jawsindia.com

SMARTTECH 3D Scanners

Kadkraft Systems offers SMARTTECH 3D scanners, which are based on structured light principle, are fast emerging as the latest tool to accelerate product design through reverse engineering and quality inspection. SMARTTECH3D scanners are the global technological leaders offering the highest resolution white light and green/blue light 3D scanners. Its highest resolution 24Mpixel colour scanners can scan most accurately both colour and texture. The scanners come from Poland and have been developed by some of the world's leading optics scientist and engineers. The scanners have been used in diverse applications: Styling, design, and reverse engineering; Prototyping; Retrofitting design; Aerospace; Quality control and inspection; Forensic application; Casting and forging die inspection; Digital archiving of museums artefacts; Jewellery design. Leading automotive OEMs and T1/T2 suppliers are using SMARTTECH 3D scanners for quality inspection by replacing CMMs. The touch less measurement using 3D scanners allows complex profiles to be scanned which is not at times possible by touch based CMM technology.



Advanced SMARTTECH3D MEASURE software uses the dense point cloud data generated by 3D scanners and convert them to precise 3D CAD models. For quality inspection one can scan the manufactured parts and compare it with the designed model to get an automatic deviation report. Such quality inspection is much faster and accurate compared to the manual inspection. At Opel, one of the customers of SMARTTECH3D scanners, the inspection rate has gone up from 4 to 30 parts per hour. Automated inspection using a robotic arm mounted with a SMARTTECH3D scanner is a proven solution to effortlessly scan large parts. Leading organisation like GE, NASA, Boeing, Opel, Volvo, VW, BMW, Adidas, Bosch, Whirlpool, US Army etc, are using SMARTTECH3D scanners successfully. Indian's leading design engineering company- Kadkraft Systems has been appointed as the sole distributor of SMARTTECH3D scanners in India.



Contact:

Kadkraft Systems Pvt Ltd
D-133B, Phase VII, Industrial Area, Mohali, Punjab 160 055
Mob: 90231 72022 • E-mail: contact@kadkraft.com

Pankaj

Always moving..innovative products developments

Pioneer manufacturer & exporters of Wire Wound Potentiometers since 1959

Moving with time and technology, adopting new materials has developed the Wire Wound Potentiometers, Type R.W-1 with Plastic Shaft.

PRESENT	FUTURE	
		
Shaft Length 19 mm Metal Shaft	Shaft Length 19 mm Plastic Shaft	Shaft Length 25 mm Plastic Shaft

Features

- High Electrical Insulation • High Electrical Breakdown Voltage
- Good Mechanical Strength • Smooth Rotation • High End stops torque
- Screw driver slot for pre-setting • Straight knurling on the shaft for firm grip while rotating the shaft • Use side screw type knob
- We recommend 6 mm collet knobs for firm collet action

Manufacturers & Exporters:

Pankaj POTENTIOMETERS PVT. LTD.

201-B, Udyog Mandir No.1, 7-C, Pitamber Lane, Mahim, Mumbai 400 016, India
 Tel. : +91 22 2446 5778 • Mobile : +91 98690 50801
 E-mail : pankaj.potentiometers@gmail.com • Website: www.pankaj.com

Subscribe to

Industrial Products Source

at ₹300/- for 1 year

VOLTAGE FLUCTUATION & POWER FAILURE IN CNC MACHINES CAUSING

TOOL BREAKAGE

PRODUCTION LOSS

JOB REJECTION

Install ACCUSTOP Axis Drop Preventer/PFM

Function of ACCUSTOP

The unit senses the three phase input voltage of the CNC machine and in the event of Voltage Fluctuation or Power Failure, the voltage to the brake is cut-off in advance thereby preventing the gravity axis of the CNC machine from dropping.



ADVANTAGES

Sensing of Voltage Fluctuation, Power Failure & Phase Imbalance

Creates auto emergency during voltage fluctuation and power failure

No changes required to the CNC machine parameters and the CNC system

Compact Design / Easy wiring

Maximum of 5 contacts can be provided

Suitable for all types CNC Systems and controls

Manual Emergency can be interfaced

Unit can be mounted inside the electrical panel of the CNC machine

Suitable for all types of CNC Machines



RK CNC SOLUTIONS

117/5A, Ramanna Flour Mill Building,
2nd Main Road, Peenya 2nd Stage,
Peenya Indl. Area, Bangalore - 560 058.
Mob. : +91-97414 97292, 97419 85519
E-mail : rkcncsolutions@gmail.com

Electrical Insulation Tape – FR

Sudhakar PVC Products Pvt Ltd offers Electrical Insulation Tape – FR. Special Features: Manufactured as per IS 7809 Part 3/Sec-1; Flame retardant; Uniform thickness and width; Controlled primer coating; Proprietary formulation of rubber-based adhesive; the non-migratory, non-oozing adhesive that presents telescoping; High stability and ageing characteristics; Water and weather resistant, also resistant to acids, alkalis, oils, greases and gasoline; Withstand short circuits/leakage currents; Superior mechanical support at high operating temperature (up to 100°C). Specifications – Nominal thickness: 0.125 + 0.025 mm; Tensile strength: 150 N; Adhesion to steel: 1.6 N/10 mm width (min); Adhesion to grip: 1.4 N/10 mm width (min); Electric Strength at RT: 40 kV/mm; Electric Strength after 24 hours Humidification at 27°C: 35 kV/mm; Flammability: Flame retardant; Insulation Resistance: 1 x 10⁵ M-ohm.



Contact:

Sudhakar PVC Products Pvt Ltd
 Unit III, Plot Nos: 26/N, 26/O and 26/P, Sy No: 354
 Industrial Park, Muppireddypally (V), Manoharabad (M)
 Medak Dist, Andhra Pradesh 502 336
 Mob: 76600 25551 • E-mail: sales.cables@sudhakarind.com

FRP/GRP Poles

FRP Poles by Sumip are high in strength, low in weight, easy to install and highly durable. They are shock as well as corrosion resistant, hence ideal for any type of environmental conditions. Sumip's FRP/GRP Poles are widely used in industrial, commercial and lighting applications. Advantages: High strength; Low maintenance; Light weight; Non-conduc-



tive; and Corrosion Resistant. Available height from 2.5 m to 12 m, and in different colour options; Wind velocity up to 250 km/hr. Applications: Street lighting; Highway lighting; Flood lighting; Docks/Water fronts; Offshore platforms; Traffic signal poles; Smart poles; Flag poles; Sign Board poles; and Solar poles.

Contact:

Sumip Composites Ovt Ltd
 1 to 5 Panchratna Industrial Estate, Sarkhej-Bavla Road
 Changodar, Ahmedabad, Gujarat 382 213
 Mob: 99250 03594 • E-mail: sales@sumip.com

Manufacturing Intelligent Compressed Air® Products Since 1983

Safety Air Gun



Cold Gun



Super Air Knives



Mini Chip Vac



Line Vac



Ion Air Cannon



Flat Super Air Nozzle



Chip Trapper



Cabinet Cooler



Authorized EXAIR Distributor



**AUTOMATION
 CONTROL
 INSTRUMENTATION**

ACI ENGINEERS



Unit No.49, 1st Floor, The New Modella Co-operative Premises Society Ltd
 Padwal Nagar, Wagle Industrial Estate, Thane (W) 400 604. Maharashtra
 Tel: 022-20814447/25804448 • Email: info@aciengineers.in / sales@aciengineers.in

www.acipneumatics.com; www.aciengineers.in

Snap Action Switches

VG Electric offers CHERRY range of switches (from ZF-TVS a Joint Venture between ZF group Germany and TVS Group), viz: miniature and sub-miniature snap action micro switches, Sub-miniature water proof switches, key board switches, push wheel switches, rocker switches, Reed Sensors, Reed Relays, Solid State Relays. The micro switch range is available from 0.1 amp to 20 amps. A plain button actuator or a variety of integral actuators to suit specific requirements does actuation. These switches are available in standard and light operating force from 5 g to 500 g. Cherry has recently introduced Rocker Switches in illuminated and non-illuminated Series with variety of contact configurations such as SPST, SPDT, and DPST. These are available from 4 amps to 20 amps as per requirements. Needless to say CHERRY provides world class products, which are approved by the best institutions such as UL, CSA, CE, VDE, etc.

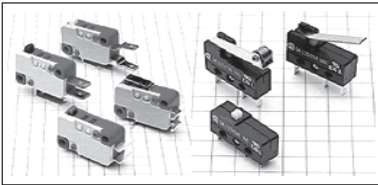

Contact:

VG Electric
27 Amrit Niwas, 2nd Floor, 165 K M Sharma Marg
Lohar Chawl, Mumbai 400 002
Telefax: 022 – 2201 8647
E-mail: sales@vgswitches.com

Gears, Gear Components & Gear Assemblies

Eppinger Tooling Asia offers a wide range of gears, gear components and gear assemblies. Established in 1925 in Denkendorf, Germany, today the company is well equipped to offer a wide range of gear assemblies, gear components and high precision gears – both standard and custom built. State-of-the-art manufacturing and quality control facilities ensure top quality, way above the local makes.

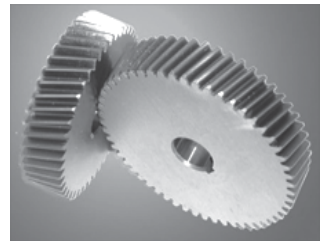

The product range covers Spiral bevel gear sets: 10 to 1 ratio dia 457 mm; 2 to 1 ratio dia 406 mm, module up to 12.7; 1 to 1 ratio dia 323 mm; hobbed gear dia 500 mm x 8 m; hardened and profile ground spur and helical gears – dia 330 mm x 5 m; internal gears – dia 152 mm x 3 m. While Eppinger gears are exported to Europe, Korea, etc, in the domestic market, it is very well received for almost all critical applications like machine tools, railways, textiles, automation, automotives, engineering, pumps, compressors, printing machines, etc.

Contact:

Eppinger Tooling Asia Private Limited
SF No: 345/2A-2B, Kondampatty Village, Kinathukadavu
Pollachi Taluk, Coimbatore, Tamil Nadu 641 202
☎ 04259 – 304 032 • Fax: 04259 – 304 018
Mob: 088700 13053 • E-mail: eppinger@dataone.in

Attention.....

Readers/Subscribers/Advertisers

Due to Covid 19 Pandemic we couldn't bring out our magazine **Industrial Products Source** from March 2020 to February 2021 issues.

Now, we hope to continue our publication with March 2021 issue. We seek your continued patronage like before to reach you regularly without break.

Bonafide Subscribers will get an extension to the magazine (depend on their Subscription validity).

High Performance Multi Spring Seal

Chem Seals Engineering Pvt Ltd manufactures High Performance Multi Spring Seal Type CSEP. Features: it is designed for high speed and high pressure application; the stationary multi-spring design maintains a stable fluid film even at extremes of speed and pressure; the axial compact design allows for the use on pumps with close bearing centres; it is ideally suited to use on offshore, pipeline and injection duties and power generation plants. Operating Condition: Temperature: -40°C to 260°C; Pressure: Up to 175 bar (g); Speed: 55 m/s.



Contact:

Chem Seals Engineering Pvt Ltd
10 Ddhapura Industrial Estate
Gaiwadi Lane, Off S V Road, Goregaon (W)
Mumbai 400 062
☎ 022 – 2871 2765, 2877 2286
E-mail: chemseals@chemseals.com

Mobile Flow Meter Calibration Skid

Nagman Flow-Level Systems And Solutions supplies Mobile Flow Meter Calibration Skid Series Mobi-FMCS. It is a compact mobile flow meter calibration solution suitable for those who have limited space and/or who need to Move the System to different sites/locations for Spot Calibration thro comparison method with a pre-calibrated master flow meter. DN 6 up to DN 50/80 (System comes in two types – Skid mounted and Trolley mounted – maximum flow 1500 LPM. DN 6 up to DN 100 (System is housed in a mobile skid on wheels, which can be lifted and placed in a truck chassis for mobility and or stationed at a chosen site location – maximum flow 2500 LPM. Reference Masters: Electromagnetic Flow Meter with Calibrated Accuracy $\pm 0.2\%$; For Enhanced Accuracy: Coriolis Mass Flow Meter with $\pm 0.1\%$ accuracy can be used as Masters.



Contact:

Nagman Flow-Level Systems And Solutions LLP
No: 168/7, Chennai Bangalore National Highway
Chembarambakkam, Chennai 600 123
☎ 044 – 6677 7052, 6677 7053
E-mail: support@nagman.com

Flash Dryers

Saka Engineering Systems (P) Ltd is a leading manufacturer and supplier of industrial drying and evaporation technology, Granulation plants and spray cooling systems. SAKA's technology is recognized in particular for its innovation, high efficiency, most reliable product quality and staying well within the demands of pollution control norms, in numerous drying applications, across diverse industries. The Flash Dryers are one of the most economical options in drying technology, needs minimum labour and lowest maintenance costs. The feed has very low residence time and is introduced in the drying chamber where it comes in contact with warm air. The stream of hot air conveys the material through the drying chamber and material dries as it is conveyed. Flash Dryers are widely used in industries such as agrochemicals, food, minerals, dyestuffs, etc. Features: Shortest residence time; Consistently delivers superior product quality; and Cost effective and economical operations. Also offers Cage Mill Flash Dryers, Spin Flash Dryers, Ring type, Dual and multi-stage Flash Dryers, etc. Applications: Agrochemicals; Chemicals; Organic and Inorganic Chemicals; Pharmaceuticals; Food and Feed products; Ceramics; Pigments and Dyestuffs; and Waste products.

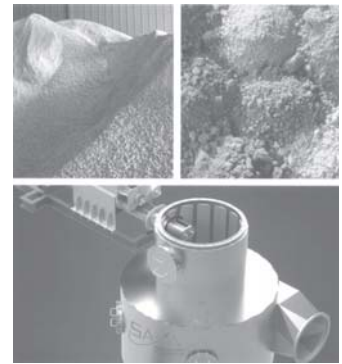

Contact:

SAKA Engineering Systems Pvt Ltd
Plot No: W45, T Block, MIDC Bhosari
Pune, Maharashtra 411 026
☎ 020 – 2711 0011 • Mob: 99238 32858
E-mail: sales@sakaindia.com

Material Handling Equipment

Sharp Engineering is a manufacturer and exporter of material handling equipment such as pallet truck, stackers, industrial conveyors, warehouse conveyors, packaging conveyors, goods lifts, car packing lift and many other customized solutions. The Company also manufactures and exports and supplies Strapping machines, Carton Sealers, Shrinks Tunnels, Shrink Chambers, L Sealer manual and all kinds of industrial packing machines.



Contact:

Sharp Engineering
2 Ram Prasad Yadav Compound, Koldongri, Lane No: 1
Sahar Road, Andheri (E), Mumbai 400 069
Telefax: 022 – 2683 5583 • Mob: 98209 39960
E-mail: sharpstrapping@gmail.com

SS Pipes & Tubes

Divine Tubes Pvt Ltd manufactures SS and welded tubes/ Pipes as well as SS seamless tubes. The process commences with the formation of welded mother tube and the tube mill from imported and tested prime quality stainless steel strips. The latest TIG multi electrode welding technique is employed for superior weld quality and 100% fusion, with argon purging and no filler metal is added. These mother tubes are solution annealed at 1060°C to 1100° in continuous annealing furnace followed by immediate quenching to prevent chromium carbide precipitation. Annealing of mother tubes ensures: Removal of stress induced during tube forming and cold drawing; Sufficient ductility and softness for cold drawing; Transformation of the weld zone to austenitic nature; Re-crystallization of metallic grains to original form and thereby improving corrosion resistance. During annealing, scales are formed on the surface of the tubes. In order to remove these, the tubes are pickled by immersing into hot pickling solutions made of nitric acid, sulphuric acid and hydrofluoric acid. SSW Pipes and Tubes finds application in areas like: Sugar, Energy, Metallurgical, Shipyard, Automobile, Food, Oil and Sugar Industries; Dairy Plant and Food products; Fertilizer plants; Chemical Plants; Power Plants; Fabrication; Railway Coaches; Sanitary/ Plumbing; Pulp and Paper Mills; Space; Ornamental; Decorative; Instrumentation; Pharmaceutical; Heat Exchangers; Refrigeration; Boilers; and Textile Machinery.



Contact:

Divine Tubes Pvt Ltd
 404-407 Aamrakunj Avis, 4th Floor, Nr: Tapovan Circle
 Visat Gandhinagar Highway, Chandkheda
 Ahmedabad, Gujarat 382 424
 ☎ 079 – 297 53031 • E-mail: divine@divinetubes.com

Hot Runner Temperature Controllers

Adroit Control Engineers offers Hot Runner Temperature Controllers. Temperature control is critically important to the overall injection molding process, especially when using hot runner systems. It affects all molding variables – flow, pressure, time and of course temperature. The Company offers both modular system and integrated system to manage all zones as complete systems.

Contact:

Adroit Control Engineers Pvt Ltd
 A-105, DDA Complex, Okhla Industrial Area
 Phase-II, New Delhi 110 020
 ☎ 011 – 4760 0700 • Fax: 011 – 4760 0701
 E-mail: sales@adroitcontrol.com

ELECTROMAGNETIC FLOWMETERS

Flow Transmitter



Applications

- Water Treatment
- Pump Testing
- Paper & Pulp
- Effluent Treatment Plants
- Waste Water & Sewerage
- Food & Dairy Processing
- Chemical Process Plants

Features:

- Rate Indicator / Totalizer Functions
- Batch Function
- Latest Pulsed DC Excitation
- Linear & Accurate
- Separate Version
- Computerized Data Logging
- Easy Maintenance



Flow Sensor

LOAD CELLS

Various Applications:

Bench, Platform, Belt, Hopper, Crane, Material Handling Scales, etc.



Suitable for applications where height is critical, material testing machines and other tension applications.

Model ULC



MINIATURE: Stainless steel load cells for special applications such as Space Constraint Areas, Robotics, R&D, Automobiles, Keyboard Testing, Piano, etc.

PRESSURE TRANSMITTER / MELT PRESSURE TRANSDUCER / DIGITAL PRESSURE GAUGE

Applications:

- Hydraulic / Pneumatic Control • Pump & Compressor
 • Pharmaceuticals / Food • Off-Road Vehicles • Process Controls
 • HVAC • SMART • Water Management • Petrochemicals • etc.



OTHER PRODUCTS:

- STRAIN GAUGES • DIFFERENTIAL PRESSURE TRANSMITTERS
 • DIGITAL INDICATORS • FUEL ADDITIVES • JUICE DISPENSING MACHINE

HARIS

Haris Sensor Technologies Private Limited

223, Shanti Industrial Estate, S.N. Road
 Mulund (W), Mumbai 400 080

Tel.: +91 - 022 - 2567 2205 / 2567 2147 / 2081 2013

Mobile: +91 - 98200 84083

Email: info@haris.in • Website: www.harissensor.com

Butterfly Valve 2-Way with Pneumatic Double Acting/Spring Return Actuator

Incorporating the latest in valve manufacturing technologies Sude assures a consistent, high quality valve that will provide years of trouble-free service. A butterfly valve is from a family of valves called quarter turn valves. The Butterfly is a metal disc mounted on a rod. When the valve is closed, the disc is turned so that it completely blocks off the passageway. When the valve is open, the disc is rotated a quarter turn so that it allows unrestricted passage. The position of the disc is effected from outside the valve. There are different kinds of butterfly valves, each adapted for different pressures and different usage. The resilient butterfly valve, which uses the flexibility of rubber, has the lowest pressure rating. The high performance butterfly valve, used in slightly higher pressure systems features a slight offset in the way the disc is positioned, which increases the valve's sealing ability and decreases its tendency to wear. The valve best suited for high-pressure systems is the tricentric butterfly valve, which makes use of a metal seat and is therefore able to withstand a greater amount of pressure.

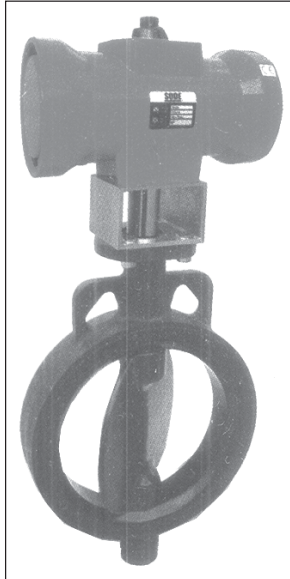

Contact:

Sude Engineering Corporation
Gat No: 94/2, Plot No: 1, Alandi Markal Road
Village Dhanore, Taluk Khed
Pune, Maharashtra 412 105
Cell: 98229 80003, 97637 19688
E-mail: sude.pune@gmail.com

Valves, Pipes Fittings & Piping System

Dipflon Engineering & Co supplies a range of PTFE/PFA/FEP/PVDF/PP Lined valves and pipes fittings, which includes Ball check valves, SS ball valves, Lined ball valves, Diaphragm valves, Plug valves, Butterfly valves, Swing check valves; Spool pipes, Dip-pipes, Reducers, Equal cross, Red tee; Dis piece and spacers, expansion bellows, etc.



Contact:

Dipflon Engineering & Co
B-413, BG Towers, Near Delhi Gate
Shahibaug Road, Ahmedabad, Gujarat 380 004
☎ 079 – 2562 4003, 2562 4169 • Mob: 099244 99948
E-mail: info@dipflon.com

Ball Valve, 3-Way Floating

ValveTech Industries is one of the leading manufacturers of superior international quality valves, offers 3-Way Floating Ball valve. Features – Class: 150; Types: L Port Diverting/J Port; Ends: Flanged/ Butt Weld; MOC: Cast Steel/SS304/SS316; Trim: SS 304/SS316; Seat: PTFE; Manufacturing Standard: BS 5351/BS EN ISO 17292; Test Standard: BS 6755 Part 1/BS EN 12266 Part 1. Optional Features available:

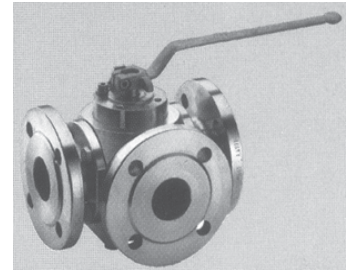

Locking arrangement; Gear/Pneumatic/Electrical Actuator; and other material compound. Size: 15 mm to 300 mm. The Company's products range includes: Butterfly Valves, Globe Valves, Gate Valves, Plug Valves, Check Valves, Lift Check Valves, Tilting Disc Wafer Check Valves, etc.

Contact:

ValveTech Industries
Kajal Heritage, Office No: 2, 3&4
Sector-12-D, Plot No: 2A, Koparkhairane
Navi Mumbai, Maharashtra 400 709
Telefax: 022 – 2754 9193 • Mob: 96994 70055
E-mail: info@valvetechindustries.in

Metal Working Fluids

Strub India Pvt Ltd, Subsidiary of Strub Swiss Tribology, Switzerland supplies a range of Metal Working Fluids for the metalworking industry; Industrial Lubricants for industrial applications, etc. The Company offers STRUB Stabillilo Cut 1, which is a universal metalworking fluid for all cutting operations without addition of any biocides. It is applicable for milling, turning, drilling, etc. for all materials. STRUB Stabillilo Cut 2 is a biocide-free metalworking fluid containing high proportion of additives which has excellent extreme pressure properties. For all high-end cutting operations and especially for thread turning, drilling, reaming, punching and drawing of all kinds of FE and non-FE materials including aluminium, aluminium alloys, stainless steel, titanium and all heavy metals.

Contact:

Strub India Pvt Ltd
Gat No: 139, A/p Kuruli, On Moi Road, Nr: M-tech
Chimbli Phata, Tal: Khed, Dist: Pune, Maharashtra 410 501
☎ 02135 – 610 206 • E-mail: strub@strub-lube.com

Brass Fittings

Sunraj Industries supplies Brass Fittings such as Brass Forged Adaptors, Brass Forged Distributors, Brass Air Vents, Brass Flange Nuts, Brass Unions and Plugs.

Contact:

Sunraj Industries
216-218 Veena Industrial Estate
LBS Marg, Vikhroli West, Mumbai 400 083
☎ 022 – 40328 7575, 2577 0075 • E-mail: mail@sunraj.com

Planetary Gearbox PE/PBE Series

Eppinger offers Planetary Gearbox PE/PBE Series. The gearbox PE complete the whole range of Eppinger automation gearbox series consisting of high-end planetary gearboxes, right angle gearboxes, hypoid gearboxes, cycloid gearboxes as well as various combinations thereof. The right angle gearbox

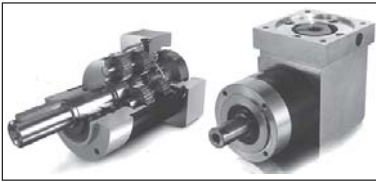

PBE rounds off this series with its prestage bevel gearbox. Smooth running is achieved through the use of Gleason Type spiral bevel gears in the pre-stage of the gearbox. Features and benefits: Case-hardened and ground ring gears; Case-hardened and ground planet gears and sun pinions guarantee high transmission quality and long lifetime; Low backlash; Easiest mounting of motor through flexible flange system; High flexibility with proven hollow drive shaft system; Integrated axial length compensation to compensate for thermal expansion of the motor shaft; High torsional stiffness and high emergency of torque through robust design and optimized gear geometry; Four sizes of gearboxes for output torques between 4 and 270 Nm; Available ratios from $i=3$ to $i=512$; Lifetime lubrication; Universal mounting positions; and Protection Class IP64.

Contact:

Eppinger Tooling Asia Pvt Ltd
 SF No: 345/2A-2B, Kondampatti Village
 Kinathukadavu Taluk, Coimbatore, Tamil Nadu 641 202
 ☎ 044 – 4259 3040, 4259 3032
 E-mail: marketing@eta-tools.com

Plastic Modular Belting

UltraPlast Chainbelts Private Limited offers Plastic modular belts that are made of standard plastic modules of varying widths. These modules are held together by plastic hinge rods. The zig-zag pattern in which the modules are assembled offers great strength to the belt structure. These belts can be assembled to virtually any width and length and are driven by Engaged sprockets, eliminating the need for constant tracking. The company's other products range includes: Plastic and Stainless Steel Slat Chains, Polymer Sprockets and Gears, Guide Rails and Wearstrips, Conveyor Accessories, Machined Components for industrial applications, Engineering Grade Plastics for demanding Industrial applications.

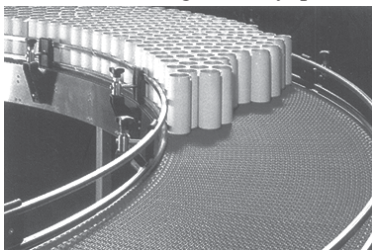

Contact:

UltraPlast Chainbelts Private Limited
 81 New DLF Industrial Area
 Faridabad, Haryana 121 003
 ☎ 0129 – 411 3186 • Fax: 0129 – 411 3188
 E-mail: info@ultraplast.in

Rotary Gear Pump, FTMB

Fluid Tech Systems offers Rotofluid brand Gear Pump, Model FTMB, which is pre-lubrication motorized type positive displacement rotary gear pump. Features: this pump is with single helical, refined gear pair and hardened and grind finished shaft. The stuffing box is relieved to suction to prevent any pressure built ups to avoid leakages through shafts; the motorized pumps set in monoblock design ensure perfect alignments, save space and reduce down time. The suction and delivery connection are available in 1/2", 3/4" and 1" size; these pumps can be operated up to pressure of 10 kg/cm² with maximum temperature up to 80oC; and highly reliable; easily portable; base plate, coupling, coupling guard is not required; compact size and space saving model; in built relief valve available; self-priming pump; bi-direction positive displacement pump; and ensure perfect alignments.



Contact:

Fluid Tech Systems
 73 Tribhuvan Industrial Estate, Near Kathawada
 Opp: Road No-11, GIDC, Ahmedabad, Gujarat 382 430
 ☎ 079 – 2290 0100 • Fax: 079 – 2290 0200
 Mob: 98790 57200 • E-mail: info@rotofluidpumps.com

PARAGONTM CE Mark Product

An ISO 9001 : 2008 Company



- Analog Timer : Din – Rail / Plug in – Panel mounting.
- Water / Liquid Level Controller
- Time Switch
- Digital Preset Timer / Hour Meter / Cyclic Timer
- Digital Preset Counter / Totaliser / RPM meter
- PID Temperature Controller / Indicator
- Phase Failure Relay
- Proximity Control Unit

PARAGON AUTO CONTROL

F/4, Laxmi Indl. Estate, Jay Ambe Temple Road,
 Off Station Road, Bhayander (W), Thane - 401 101. (M.S.) India.
 Tel.: 91-22-2814 9014 Telefax : 91-22-28180978
 Email: info@paragoncontrol.com Web : www.paragoncontrol.com

Liquid Ring Vacuum Pumps

Toshniwal, leaders in vacuum engineering over 40 years, now provides further solution to customer's vacuum needs in manufacturing of liquid ring vacuum pumps that offer optimum performance and reliability. They offer minimal water consumption and an innovative impeller design that assure extremely quiet operation and extending its life even under harsh condition. The most advanced manufacturing process with the objective to reduce manufacturing times shortening delivery times. Hydrotwin – PLC Controlled roots + LRVP package for high vacuum application with total liquid recirculation; Capacity to 3900 m³/hr max vacuum 2 mbar. Hydro sys – Centralized package vacuum units with total or partial water recirculation; Capacity to 3500 m³/hr; max vacuum 33 mbar. Typical applications: Distillation, Drying, Material Transfer, Power and steel, Food processing, Paper, General Vacuum, and Textile.

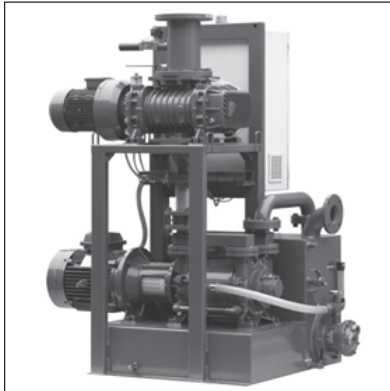

Contact:

Toshniwal Instruments (Madras) Pvt Ltd
267 Kilpauk Garden Road Chennai 600 010
☎ 044 – 2644 8983, 2644 8558
E-mail: sales@toshniwal.net

Pneumatic Boiler Tube Cleaner

The tubes and piping of boiler, heat exchangers, and condensers must be kept clean in order to maintain 100% production efficiency and to prevent damage to the boiler due

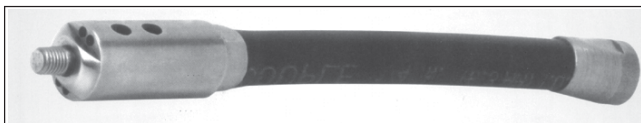

to overheating. Being one of the pioneers in tube cleaning field DBX Tool has developed new pneumatic boiler and heat exchanger tube cleaner, which cleans tubes thoroughly by mechanical means. This air motor along with cutter or brush goes inside the tubes of vessels and cleans the tubes. This system consists of few moveable parts, easy to operate, faster, economical and versatile. It saves more manpower and time for handling tube cleaning job, gives polished inner surface, can clean straight and bent tubes (even U bents) of any length from tube ID 25 mm up to 150 mm ID. Air pressures require is 6 kg.

Contact:

D H Boiler Exchangers Tools Pvt Ltd
3101 Bhandup Indl Estate, Pannalal Silk Mill Compound
LBS Marg, Bhandup (W), Mumbai 400 078
☎ 6671 1682 • Fax: 022 – 2594 8419
E-mail: dh.boilertools@gmail.com

Ceramic Thread Guide

Duratech manufactures high alumina ceramic thread guides suitable for a wide range of textile applications – for texturizing, twisting, winding, cotton spinning, jute industry, HDPE, Knitting, looms, silk industry, nylon and rayon industries. The Ceramic Thread Guides are of high quality and are highly polished to avoid broken filament. Features: Highly wear resistance, unmatched quality, and highly finished.

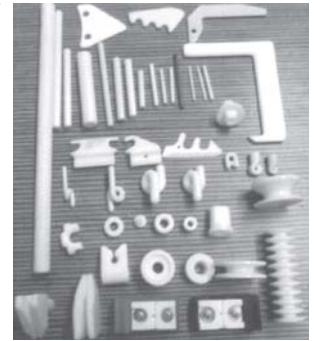

Contact:

Duratech

Shree Apartment, Shop No: 7, Plot No: 40 & 41
Sector-1, Sanpada East, Navi Mumbai 400 705
Mob: 98213 28803, 80808 88842 • E-mail: duracera@gmail.com

Short Stroke Cylinders

Janatics India Private Limited offers Short Stroke Cylinders of Bore sizes dia 12, 16, 20, 25, 32, 40, 50, 63, 80 and 100 mm. Standard strokes up to 100 mm.

Contact:

Janatics India Private Limited
E-25, SIDCO Industrial Estate
Kurichi, Coimbatore, Tamil Nadu 641 105
☎ 0422 – 267 2800 • Fax: 0422 – 267 2304
E-mail: janatics@md2.vsnl.net.in

Vacuum Pumps

PPI Pumps, an ISO 9001: 2008 certified company, and is one of India's largest vacuum pumps manufacturers. They offer a range of vacuum pumps in different sizes and capacities:

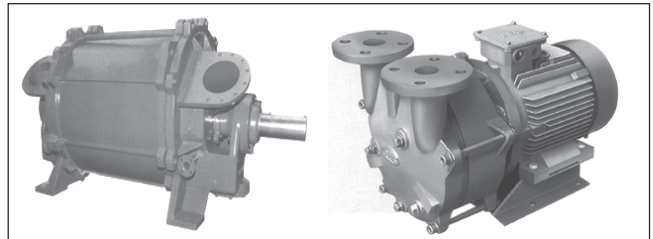

Close Couple Vacuum Pump CC Series (pix, left) – Suction capacity: 20 to 200 m³/hr; Power consumption: 0.75 kW to 5.5 kW; Maximum vacuum: 700 mm of Hg (G). Used in plastic industries and breweries. PRV Series Liquid Ring Vacuum Pump – Suction capacity: 7200 to 16000 m³/hr; Power consumption: 110 kW to 500 kW; Maximum vacuum: 700 mm of Hg 9G); widely used in Pulp and paper industries, and Sugar mills.

Contact:

PPI Pumps Pvt Ltd
14 & 16 C, Phase 1, GIDC Estate, Vatva
Ahmedabad, Gujarat 382 445
☎ 079 – 2583 2274, 3251 6741
E-mail: sales@ppipumps.com

Slewing Bearings

Apex Renogear is a solution for middle size and heavy-duty slewing bearings. Renogear is part of the Xubi Group of Spain, a worldwide leader and a reference in mechanical transmission components. Renogear meets the highest quality demands and is, therefore, able to meet the current customer demands. Renogear produces slewing bearings up to 4.500 mm external diameter. Renogear offers a complete range of slewing bearings customized and adapted to the demands of the customer: single row ball bearing; double row ball bearings; cross roller bearings; three row roller bearings; and roller ball bearings. The gear teeth can be external and internal, both helix and straight. Renogear offers slewing bearings for many applications such as wind generators heavy-duty machinery, mining equipment, cranes or machine tools, among others.

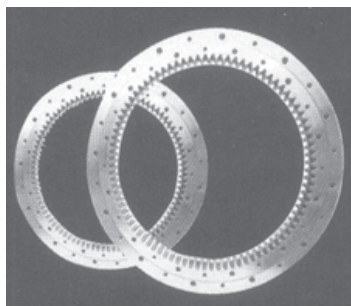

Contact:

Apex Precision Agencies
 303-308 Krishna Bhuvan Annexe
 22-B Govandi Station Road, Deonar, Mumbai 400 088
 ☎ 022 – 6146 4444 • Fax: 022 – 2556 4987
 E-mail: sales@apexprecision.co.in

Limit Switches

Bohmen Industries manufactures and supplies a wide range of electromechanical limit switches and allied assemblies, which are safe and extremely durable. The company customizes their products as per the requirements of the clients. The switches are used in most major engineering industries that either relay on or help in process automation. Bohmen's products range includes: General Purpose Limit Switches; FRP Position Swit-ches; Safety Switches; Precision Switches; Weather Proof Switches; Flame Proof Switches, etc. These products find applications in various industries for different processes as a pilot control unit for any electronic/electromechanical system; Material Handling Equipment; Material Processing Machines; Textile Processing Machines; Rail Coach Safety Systems; Lubrication Systems; Packaging Machines; Food Processing Equipment, etc.

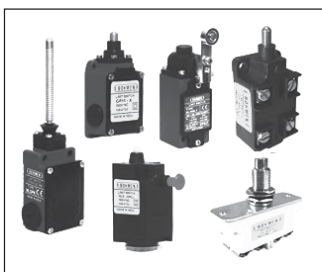

Contact:

Bohmen Industries
 114 B, Marudhar Industrial Estate
 Goddev Road, Bhayander (East), Thane 401 105
 ☎ 022 – 2819 3279, 2818 3279
 E-mail: bohmenindia@gmail.com

GAS ANALYSERS

SO₂% MEASUREMENT SOLUTION FOR JUICE AND SYRUP SULPHITATION



Ambient Air Quality Monitor
 ACE 10000 AAQ ECO



Online Zirconia Oxygen Analyser (Unheated Probe)
 ACE 2000 UHP



Dilution Based CEMS
 ACE 10000XX DP



Hot Extractive CEMS
 ACE 10000X HE



Food Ripening Analysers
 ACE 60 FR



Dust Monitor Single Pass Transmission Meter
 ACE 10000 OT



Dust Monitor Double Pass Transmission Meter
 ACE 10000 OTPT



Online Zirconia Oxygen Analyser (Heated Probe)
 ACE 2000 HP

PORTABLE ANALYSERS



Portable Stack Gas Analyser
 ACE 9000 CY MULTIGAS



Carry Case Emission Analysers
 ACE 9000X



Combustion Efficiency Monitors
 ACE 7000



Carry Case Coal Gas Analyser
 ACE 9000X CGA

ONLINE DETECTOR

Multichannel Gas Detection System
 ACE 40



*** Fully Indigenous * Sensors with 3 years warranty**
*** Assured Service Back-up * Low Cost**
*** Meets latest CPCB Norms**

ACE GAS ANALYSERS PVT. LTD



342 Edison 1, Tesla Industrial Park
 Raheja District II, Near Prabhat Dairy
 MIDC Juinagar, Navi Mumbai 400 705
 Tel: 022 - 2087 1056 / 022 - 2087 1057
 E-mail: sales@acegasanalysers.com
 Website: www.acegasanalysers.co.in / sme.in/acegas

DEALERSHIP ENQUIRIES SOLITED

YHB Mist Cleaner

YHB is a leading manufacturer of Mist Cleaners from South Korea. The CNC machines are operating with water soluble coolant or oil coolant. Within few hours of working, lots of mists are formed around the machine. The particle mists (1 to 10 micron range) pollute the working area in the factory and is definitely harmful to the operator of the machine. If they would inhale that kind of improper air, it will cause them to get occupational disease and the company would have to face loss of machine life and decrease in production rate. The Mist Cleaner will purify the atmosphere of polluted environment effectively. It also prevents accident and fire from sticking slippery oil mist on the floor by means of purifying the working area. Mist Cleaner is a profitable device to purify the polluted working area by removing over 95% of the mist in the factory. Recovered oil returns to the tank for re-use and the clean air is returned to the work place. Mist Cleaner can be mounted on top of the machine or in separate stand. On an environmental point of view all shop floor machines should be fitted with Mist Cleaners. YHB Mist Cleaner's structure is simple to change the filter inside and small size to install on the machine. After filter options are also available for these models. YHB products also include Cyclone dust collector, Fume Cleaner, Electrostatics Precipitator, etc.

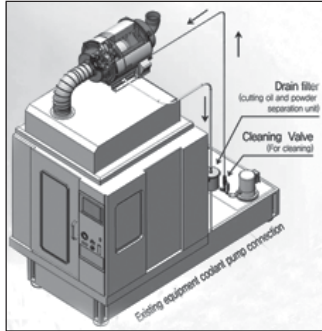

Contact:

Amcats Pvt Ltd
B-20, Punit Industrial Estate, D10/11A
Thane Belapur Road, Turbhe, Navi Mumbai 400 705
☎ 022 – 2763 5005 • Fax: 022 – 2763 5007
E-mail: hemani@amcats.com

Engineering Unit

Nippon India offers microprocessor based engineering unit with Hi and Lo alarm setpoint with relay O/P and process value (PV) re-transmission. 4-20 mA DC with 24 V DC transmitter supply. All inputs and range selectable from the front panel switches. Features: T/C Type: J, K, R, S, T, E RTD Type: Pt-100/CU-53; Analogue: 0-10 V DC/4-20 mA DC (Scalable – 1999 to 9999 with selectable DP); Display: 0.8" height, 4-digit; Mains: 24 V DC; Dimensions: 48 (h) x 96 x (w) 78 mm (d).



Contact:

Nippon India
237/8 Sonal Link Indl Estate, Building No: 2
Link Road, Malad (W), Mumbai 400 064
☎ 022 – 4062 0000 • Fax: 022 – 4062 0099
E-mail: infpo@nipponindia.com

Back Pressure Regulator

Steam Equipments, an ISO-9001: 2015 Certified Company offers Steam Back Pressure Regulator that is designed for gas or liquid service to control the inlet pressure. It is used to maintain the constant pressure in sampling system or act in a relief valve capacity. These BPRV are used in Steam and Water Analysis Systems, Instrumentation Systems, etc. Features: Suitable for corrosive applications; Low operating torque; Compact design; Highly sensitive, Diaphragm Type; Stainless Steel body material; Accurate adjustment. Specifications – Type: Spring loaded Diaphragm type; Body Material: Stainless Steel 316, Brass, Monel; Seat material: Stainless Steel diaphragm with Teflon lining; Inlet Pressure: 3 to 6 kg/cm² (Std); Set Pressure: 2.5 kg/cm²; Setting: Adjustable with socket screw lock nut; Mounting: Surface; End Connections: 1/4" OD (Std) Double ferrule compression fitting; 3/8" OD Double ferrule compression fitting; 1/2" OD Double ferrule compression fitting; Pressure Gauges: Inlet and outlet, 1/4" NTP, SS casing.



Contact:

Steam Equipments
Plot No: 44, Tiny Co-Op Indl Estate
Kondhwa, Budruk, Pune, Maharashtra 411 048
☎ 020 – 2693 0908, 2693 0960
E-mail: sales@steamequipments.com

Incremental Encoders

Kuebler Automation offers Incremental Encoders. Dimensions from dia 24 mm to dia 100 mm; Optical and Magnetic scanning; Working temperature range -40°C to +105°C;

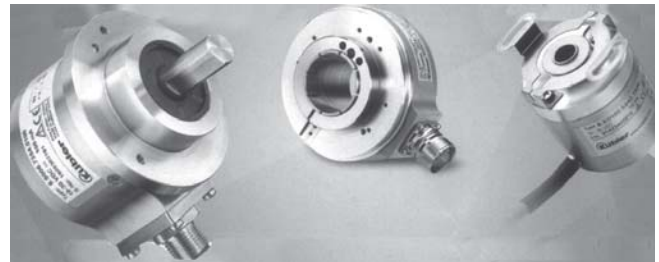

Resolution up to 36,000 ppr; HTL, TTL, and SinCos output signal. The Company also offers Absolute Encoders Single turn, Multi turn, Bearingless Encoders; Draw-Wire Encoders; Motor feedback Systems for Servo Motors; Magnetic Length measuring Systems, Shaft Copying Systems, Inclometers, Slip Rings, Signal Converters, Displays and Counters, Process Devices, Safe Speed Monitors, etc.

Contact:

Kuebler Automation India Pvt Ltd
Plot No: A-20/2, Phase 1, Chakan MIDC, Mahalunge Ingale
Tal: Khed, Dist: Pune, Maharashtra 410 501
☎ 02135 – 618 200 • Fax: 02135 – 618 232
E-mail: info@kuebler.in

Knife Gate Valve

Fluidtecq Pneumatics offers full SS Knife gate valves. Features: Single piece Cast body; Uni-directional and bi-directional valves to suit varied applications; Metal resilient seating; Design as per MSS SP BI; Simple compact design and construction; Manual/pneumatic/hydraulic/motorized operation; Maximum operating pressure: 150 PSI; Hardened beveled gate and hardened seat for shearing and sealing; Close tolerance machining between bodies; Precision ground gate; Removable insert ring for ease of repair; CI Fg 260 Gr, CS Gr WCB, CF8, CF8M, SS316L bodies; Sizes range from 2" to 24" (larger sizes made available on request); ON/OFF and Proportionate opening/closing; 100% factory tested as per MSS SP 81; the wedge angle is maintained such that it cuts through the most stubborn materials; the hand wheel and shaft is designed to withstand high torques and offers better force.

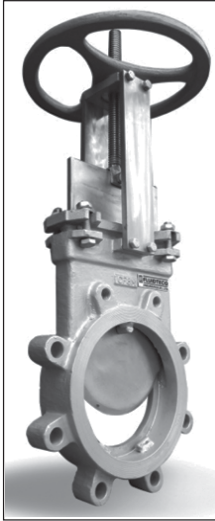

Contact:

Fluidtecq Pneumatics Pvt Ltd
W-97 MIDC, Anand Nagar, Ambernath East
Dist: Thane, Maharashtra 421 506
☎ 0251 – 262 0491, 262 0007 • Mob: 99700 68207
E-mail: fluidtecq@gmail.com

Flow and Level Sensors

Gebrueder PG offers Flow and Level Sensors. Features: these highly reliable sensors are manufactured by EGE Elektronik, Germany. They include thermodynamic flow sensors for liquids and gases of up to 160°C medium temperature. Level sensors with microwave technique are available. Special proximity switches for temperature up to 200°C are also made; they have features such as wide range of standard and Inline sensors, and reliable with quick response sensors for liquids and gas mediums; these are suitable for temperature of medium up to 160°C and have switching and analog output; these sensors have compact units with digital or LED array display; inductive Proximity switches for temp. 120°C, 160°C and 200°C are made by EGE; and sensors are made of materials which are approved for food and pharma applications. The company is marketing products of EGE Elektronik, Germany. The products include metal detectors and instrumentation products like flow, level sensors, etc.



Contact:

Gebrueder PG
303 Ashirwad Industrial Estate, Building 3
Ram Mandir Road, Goregaon (W), Mumbai 400 104
☎ 022 – 2676 3587 • E-mail: gebrueder@yahoo.co.in

Handheld Laser Welding Machine

Indus Arc Power Pvt Ltd offers Handheld Laser Welding Machine. Hand-held welding machine is integrated with fibre lasers; handheld welding head, laser control system, safety light extraction system, and water cooling system. The overall design is small, beautiful, and portable, which make it easy for customers to choose their working environment without space limitation. Specifications – Laser Power: 500/800/1000/1500 W; Wavelength: 1080 nm; Feeding Fiber Cable Length: 15 m; Tuning Range of Power: 10-100%; Protective Gas: Ar N2/He; Modulation Rate: 0-20 kHz; Feeding fiber Core dia: 50 µm; Short/Long term power Instability: ±1% / ±2%. Applications: Precision sheet metal fabrication, Flexible Bellows, Kitchen equipment, metal door frames, SS enclosures. The Company also offers Laser Cutting System, Jewellery Laser Welder, Laser Marking Machine, Inverter Welding Machines, MIG and Double Pulse MIG Welding, CNC Plasma and Gas Cutting System, etc.



Contact:

Indus Arc Power Pvt Ltd
#17C/6, 2nd Main Road, 2nd Phase, Peenya Industrial Area
Bangalore, Karnataka 560 058
☎ 080 – 4890 4157 • E-mail: sales@indusarc.com

Gear Boxes & Geared Motors



Manufacturers of
Worm Gear Boxes, Lift Duty Gear Boxes
Special Gear Boxes & Geared Motors



SHACON ENGINEERING COMPANY

14, Veena Dalvai Industrial Estate, S V Road
Oshiwara, Jogeshwari (W), Mumbai 400 103

Tel: 2678 1566 / 6695 9526 • Fax: 022 - 2678 6296
E-mail: shacon@vsnl.com / shaconeng@gmail.com

Glandless Transformer Oil Pumps

Flow Oil Pumps Private Limited is the new name of Flowwell Pumps & Meters which had commenced its operations in 1993, as a Designer and Manufacturer of Transformer



Oil Pumps. The Company offers premium range of Glandless Transformer oil pumps under the Brand FLOWWELL, which caters to all types of Transformer oil cooling requirements including traction duty and for heavy electrical engineering. These are offered in Centrifugal, Axial flow and



Centrifugal inline design suitable to meet distribution power transformer up to 765 kV, Generating Transformers, EMU, Locomotive transformers. The pumps are manufactured with state-of-the-art Technology and have all the requisite facilities, equipment to ensure that the pumps delivered is of the highest possible level of quality, guaranteeing reliability and longer life. Standard motors are as per IS 325 and Pump testing are as per IS 5120, ISO 3555. The products meet the specification requirements of IEC 34-1, EN 51216-7, and IEC 349-2. API 685 for canned motor pumps. Flow Oil meets the customer demand in Glandless application requirements.

Contact:

Flow Oil Pumps Private Limited
No: 2/80/118, KSR Layout, Devarachikkanahalli
Bannerghatta Rd, 11M Post, Bangalore, Karnataka 560 076
☎ 080 – 2648 4068, 2648 2095
E-mail: flowoilpumps@hotmail.com

Magnetic Grills

Santosh Magnetic Works offers Magnetic Grills, which are used for separating tramp iron pieces that contaminates dry, granular or powder materials like plastics, sugar, coffee, tea, chemicals, etc. They are mainly located in the Hopper/Chucks. Available in various sizes and in rectangular, round, and square shapes.

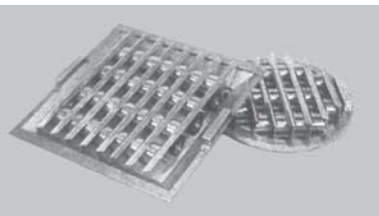

Contact:

Santosh Magnetic Works
6/B Shobhana Apt, 1st Floor, K Vishwasrao Road
Nr: Maratha Colony, Dahisar (East), Mumbai 400 068
☎ 022 – 2828 3294, 2896 5519
E-mail: santosh_magnetic@hotmail.com

Marconite Earthing System

Marconite earthing system is a conductive aggregate that provides permanent, stable as well as low resistance earthing solutions that are workable in several complex ground conditions. It enables the electrical engineers to get a stable, permanent and low resistance earthing solutions that help the engineers handle the most complex soil conditions and get



right earthing solutions across the world. Marconite is manufactured in an extremely careful manner by the specialists and is packed in UV resistant valve topped poly sacks and palletized. This type of earthing is dark grey and has a granular consistency. Marconite is the perfect alternative to traditional sand as well as aggregate materials that are utilized as cement mixers. Advantages of Marconite Earthing over Chemical Earthing: Marconite earthing, the new earthing system by Inter Tech is much safer and beneficial as compared to chemical earthing. In chemical earthing, several chemicals such as Bentonite, charcoal, and salt deeply impact the sub-soil of the location of earthing through leaching as well as polluting water tables. Marconite earthing is in complete sync with your earthing needs as it has low resistivity (0.001 Ω in comparison to Bentonite's 3 Ω). Other features of this kind of earthing are versatility, high strength, chemically inert and easy to use. Inter Tech introduced Marconite® conductive aggregate in 2011, through a joint development and research that was conducted at the beginning of the seventies by PMC and Guglielmo Marconi's Marcony Company Ltd. The company is instrumental in catering to all kinds of electrical earthing applications of railways, industrial complexes, gas, power stations, electrical systems and water plants, etc. Applications: Marconite® is perfectly suitable for every soil condition as well as the steep ground. Some of the features which make Marconite® an ideal earthing are its non-corrosiveness, versatile nature and performance. Marconite® offers its clients highly dependable, durable permanent structures that require maintenance, replacement or zero repairs. Marconite® concrete earth electrodes have a better track record. It is used within critical earthing solutions to several industries including: Power Generation, Transmission and Distribution Utilities, Defense Facilities and Equipment, Anti-Static Applications, Telecommunications, High-Speed Broadband and Media, Lightning Arrestor Earthing, Oil & Gas Production and Distribution Facilities, Rail, Underground, and Transport Networks.

Contact:

Inter-Tech
B-83 Flatted Factory, Nr: Modi Mills
Okhla, New Delhi 110 020
☎ 011 – 4102 0365
Mob: 98914 02128
E-mail: info@intertech.com.co

Inverter Cabinets, 3 CFL

Shrey Plastic Moulders offers a wide range of 3 CFL Inverter Cabinets, Model SPM P2T. Features: these are designed in accordance with the technical specifications desired by clients; available in various sizes and shapes to suit the demands of home UPS systems; the range is acknowledged for sturdy construction and long service life; the range encompasses home UPS plastic panels and cabinets, stabilizer plastic panels and cabinets, inverter front panels 600-800 VA, plastic moulded cabinets, CFL inverter cabinets and inverter front panels 800 to 1400 VA; and these are widely appreciated for high resilience, optimum strength, heat resistance and durability. The company is one of the well-known manufacturers, exporters and suppliers of plastic panels and cabinets for various electronic goods.



Contact:

Shrey Plastic Moulders
 340/19 C, Street No: 1B, Friends Colony, Industrial Area
 G T Road, Shahdara, New Delhi 110 095
 ☎ 011 – 2213 6820 • Mob: 98100 57385
 E-mail: sales@shreyplasticmoulders.com

Rotary Gear Pump, Type HGSX

The Rotodel gear pump Type HGSX is all SS-316 self-priming bi-directional positive displacement rotary pump, fitted with Teflon coated dry running DU bush bearings. Three piece design makes the pump easy cleanable, easy maintainable simply by removing four dom nuts on back cover. Mechanical seal is optional for Teflon gland packing. The mounting bracket converts the pump to foot mounting and facilitates to align the pump with electric motor of appropriate ratings on base plate at same frame height. All sizes of HGSX pumps are designed to run at 1440 RPM up to viscosity of 500 CST, however small size pump up to 1" can be run at 1440 RPM safely, even at higher viscosity up to 1000 CST but with additional horse power, for higher sizes reduce the speed to 960 RPM. This compact and efficient SS pump finds different applications for handling food products like ghee, butter fruit pulp, vegetable souse, kanji, etc. They are also used in pharmaceutical application for handling sugar solution, glycerin, glycol etc.



Contact:

Del Pd Pumps & Gears (P) Ltd
 113 GIDC Estate, Wadhwan, Surendranagar, Gujarat 363 035
 ☎ 02752 – 243 047, 243 678 • Fax: 02752 – 243 744
 E-mail: rotodel_adl@sancharnet.in

Multi Axis (4 Axis) Auto Laser Welding Machine, Galaxy WD Series













Mehta CAD CAM Systems Pvt Ltd offers Multi Axis (4 Axis) Auto Laser Welding Machine, Galaxy WD Series. The Galaxy WD 500 4-axis laser welding machine 2with rotary jig and CNC control system is for welding intersecting line, involute line, curve, point, the entire column and other arbitrary trajectories. It is specialized R&D for precision welding industry with high magnification system and well received by customers. Applications: Suitable for welding of kettle, vacuum cup, stainless steel bowl, sensor, tungsten wire, high power diode (triode), aluminium alloy, laptop shell, mobile phone battery, door head, zinc alloy artwork. Capable of welding spot, straight seam, circle, square or any plane graphs drawn by Autocad, or even dimensional graphs.

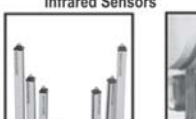

Contact:

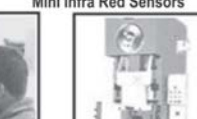
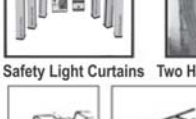
Mehta CAD CAM Systems Pvt Ltd
 Plot No: 3, Road No: 1, Kathwada GIDC
 Ahmedabad, Gujarat 382 430
 ☎ 079 – 2970 0235, 75750 09626
 E-mail: mktg@mehtaindia.com

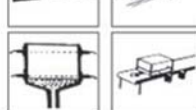
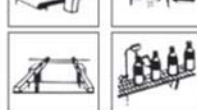
SENSORS, SAFETY LIGHT CURTAIN, COUNTERS

 Inductive Proximity Switches	 Photoelectric Sensors	 Anti Crane Collision Sensor
 Infrared Sensors	 Large Display Counters	 Mini Infra Red Sensors
 Safety Light Curtains	 Two Hand Safety Device for Rolling Key Presses	 Safety Light Curtains
 Safety Light Curtains	 Safety Light Curtains	 Safety Light Curtains
 Safety Light Curtains	 Safety Light Curtains	 Safety Light Curtains

Photon Controls (India) Pvt. Ltd
 Plot No.C 10/1, Gala No.54, NICE INDL. ESTATE,
 Ladies Proj. MIDC, Satpur, Nashik - 422 007.
 Telefax: (0253) 2355498, 2352760 • Mob: 093739 07348
 E-mail: photoncontro@gmail.com / mukund@photoncontrols.com
 Website: www.photoncontrols.com



Green Chemical Distillation Plant

Innovative Flexotech manufactures and supplies a high quality green chemical distillation plant. Its features are: the distillation of organic substances can have the volume weigh up to 800 L. The solvent, chemicals and other substances are distilled along with matured mass accuracy; no need to taking off the control panel; change of diathermic oil required every 1000 working hours; no filling the solvent container up over the level (80 liters); remove the waste after every recovery process; and organic or inorganic distillation; quick processing; recovery volume – 60/80 liters; power consume – 220 V 4.65 kW; diathermic oil – 23 kg; machine dimension – main body 1100 x 780 x 1200 mm; recovery rate – 85%; recovery time – 3 ~ 4 hours. The company is a manufacturer of high quality photopolymer plate making equipment and flexo printing machinery.



Contact:

Innovative Flexotech Pvt Ltd
435 Patel Avenue, Opp: Grand Bhagwati, S G Road
Thalje, Ahmedabad, Gujarat 380 059
Mob: 83470 03307, 98240 96180
E-mail: info@flexo.co.in

Pre Cut Gaskets

Champion Seals (India) are manufacturing wide range of Compressed Gaskets, i.e. Pre-Cut Gaskets. Features: the gaskets are manufactured as per ASME B16.21 standards suitable for flanges as per ASME B16.5 and ASME B16.47 Series A & B; it also manufacture gaskets as per IS, BS, DIN standards, and non-standard gaskets as per customer's specifications and drawings; its features include: gasket thickness range - 0.4 mm to 6.0 mm; full face gasket for flat face flanges; and flat ring gasket for raised face flanges. The company is a manufacturer of asbestos free fibre jointing sheets, compressed fibre jointing sheets and spiral wound gaskets.

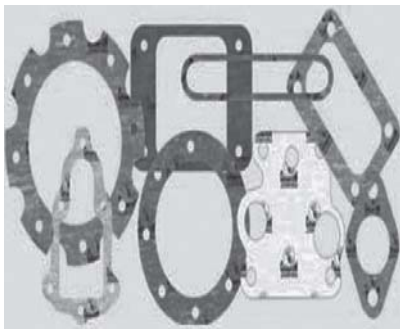

Contact:

Champion Seals (India) Pvt Ltd
1st Floor, Champion Building
Plot # 15, Parsi Panchayat Road
Near Sona Udyog Industrial Estate
Andheri East, Mumbai 400 069
☎ 022 – 2836 7311 • Mob: 98201 71162
E-mail: info@championseals.in

Industrial Rotary Vacuum Dryer

Nes India Engineers offers Industrial Rotary Vacuum Dryers. Features: this operation is under vacuum and hence it is possible to dry heat sensitive materials at temperature well below 100°C without suffering the problems associated with very long drying periods; the agitator is usually the hollow cylinders with hollow arms, this allows a considerable increase in heating surface and thereby reducing the drying time; low temperature drying under vacuum makes them more suitable for heat sensitive materials to maintain the quality; and the expensive solvents can be almost completely recovered through a suitable condenser and vacuum receiver. The company manufactures a wide range of industrial equipment like industrial agitators, material handling systems, chemical process equipment, chemical reactors, water treatment plant energy conservation systems, heat exchangers, etc.

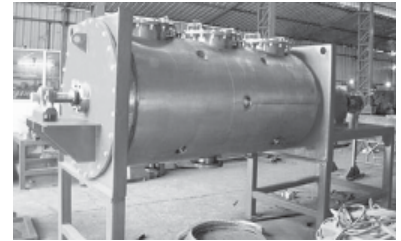

Contact:

Nes India Engineers
Plot No 106 Sector No 10 Pcntda, Bhosari Industrial Estate
Pune, Maharashtra 411 026
☎ 020 - 6510 0608 • Mob: 88059 85241
E-mail: info@nesindiaengineers.com

Water Softener Plant

Dowac Systems & Projects India offers Water Softener Plant. Features: produces zero soft water by highly acidic cation exchanger, which removes calcium and magnesium ions; these series water softener systems are designed for longer operating cycles and low regeneration cost; the systems incorporate the proven technique of counter and co-counter current regeneration flow rate to economically suit the demand of soft water for medium scale industries and commercial use; experts design and execute the production of these water softeners systems, and ensure that given requirements are fulfilled. The company an ISO-9001-2008 company is fully equipped for integrating process technology, design engineering, consultancy, installation and commissioning.



Contact:

Dowac Systems & Projects India Pvt Ltd
15/9, Primrose Road, MG Road Cross
Bengaluru, Karnataka 560 001
☎ 080 – 2559 8585/87
E-mail: info@dowacsys.com

Double Block & Bleed Valve (DBB)

Forxar Industries offers double block and Bleed valve (DBB), which replaces conventional multi-valve installations currently in use for interface with pressure measuring systems. By combining customer specified valves into a single forged block, the number of leak paths are considerably reduced and the mass of the system is lowered reducing the stresses from loading and vibration. As a result, it substantially improves installation and operational safety factors. Reduction in leakage path connections together with a one-piece solution also provides positive savings in installation costs. Features: A one-piece integral forging incorporating up to 3 ball valves or mixture of ball and needle design; Strong construction produced from one piece grain flow controlled forged body; Various flow and valve configurations available allowing true flexibility to meet all customer requirements; Monoflange is more compact than DUBLO, adding possibilities of further space and weight saving; Improved safety leak paths reduced by up to 60% less susceptibility to vibration; Installation and component cost reduced by up to 50%; Weight reduction of up to 65%; Ergonomically designed operating handles with low torque function; Incorporation of standard flange end connection (ASME B16.5) and Threaded (NPT-ANSI 1.20.1); Needle valve technology and state-of-the-art Globe OS&Y design.

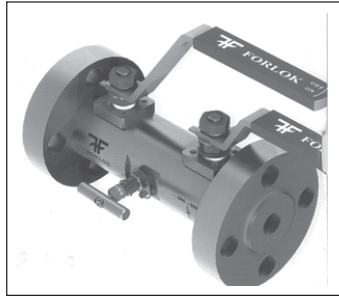

Contact:

Forxar Industries
 Unit No: B1/B2, Shubham Nx Industrial Estate
 Valiv, Dhupal Nagar, Vasai (East), Palghar 401 208
 ☎ 0250 – 690 6668 • Mob: 75066 82777
 E-mail: sales@forxarind.com

Plastic Injection Molding Components and Products

Boopee Plastics having 15 years of rich experiences in all types of Plastic Injection Molding Components and Products, provides full solution to customers from design stage to end product assembly like part and mould designing, mould manufacturing, production and product assembly under high level of quality care and control and maintains zero defects parts to customers. Boopee can handle all polymers like PP, PPCP, ABS, Nylon, PC, PBT, Delrin, Co-Polymers and all GF Grades and equivalent plastic grades for replacement of metal parts; moulding range from 1 g to 400 g with core pulling facilities.

Contact:

Boopee Plastics
 85-87 Dr Chitrambalam Layout, Alayur
 Pappanaickenpalayam, Coimbatore, Tamil Nadu 641 037
 Mob: 98420 14077, 96599 25999
 E-mail: boopeeplastics@gmail.com

Welding Machine, MOSFET Base

Welding Aids offers a wide range of DC TIG (inverter base) MOSFET base Welding Machines. Features are: its soft switch technology offers high efficiency, low power consumption, automatic protection from over current, over heat and over/under voltage. It offers TIG welding and MMA welding; up/down slope of welding current arc pre and post flow of gas; with automatic HF control; in TIG welding stitch welding option is available; the built-in circuit guarantees a good arc-ignition and crater filling. MMA welding can be used with all kinds of electrode of diameter below 5.0 mm; its features include: Fine current controlling; the arc force knob can increase the arc force and prevent the welding electrode struck to work pieces; remote control current regulator – optional. The company is engaged in trading, importing and service providing for a wide range of welding and cutting equipment such as welding cutting machines, portable cutting machine, and automatic cutting machines.



Contact:

Welding Aids
 No: 4033, Ajmeri Gate, New Delhi 110 006
 ☎ 011 – 2321 4114 • Mob: 98110 62635
 E-mail: weldingaids@gmail.com

FITZER

World Class Product Brand

PROCESS, MEASURING INSTRUMENTS & AUTOMATION

PRESSURE

- LIQUID COLOUR MANOMETERS
- DIGITAL MANOMETER
- DIGITAL PRESSURE GAUGES
- BAROMETER
- VACCUM MANOMETER
- PRESSURE SWITCHES

FLOW

- GLASS TUBE / ACRYLIC ROTAMETERS
- METAL TUBE ROTAMETER WITH TRANSMITTER / FLOW INDICATOR TOTALIZER
- BY-PASS ROTAMETER
- ELECTROMAGNETIC FLOWMETER
- FLOW SWITCHES
- AIR VELOCITY KIT

LEVEL

- LIQUID LEVEL INDICATORS
- LIQUID LEVEL TRANSMITTER
- LIQUID LEVEL SWITCHES (FLOAT OPERATED)
- CONDUCTIVITY LEVEL SWITCHES
- CAPACITANCE TYPE LEVEL TRANSMITTERS

FITZER INSTRUMENTS COMPANY (INDIA) ® Regd. Correspondence Address:
 Atali, Near Ambivali Stn. (W), P.O. Mohone, Tal. Kalyan, Dist. Thane-421 102
 Mobile: 8691816354 / 8691816355 / 8691816356 / 9426470248 / 942747248
 E-mail: fitzerindia@hotmail.com / fitzergujarat@rediffmail.com

Dealership Enquiries Solicited
Website: www.fitzerindia.com

Pull Back Clamps, TGP Series

Chamunda Equipments offers TGP Series Pull Back Clamps, which is ideal for rotational moulding. This clamp is unique in having an action similar to a wide-opening locking. Plier, but having flange body can be fastened to the fixture or Roto Mould against, which the work piece or mould half is to be clamped. It designed for attachment by welding or bolting in to front or top of base to be container or cover. Jaw open 90° to clear completely. Handle grip provides with Pipe to easy operation.



Contact:

Chamunda Equipments

Sabarmati Textile Estate, Opp: GST

Nr: Vastupal Steel

New Ranip, Ahmedabad, Gujarat 382 480

Telefax: 079 – 2752 2437 • Mob: 97244 02626, 98980 60737

E-mail: clamp@chamundaequip.com

Packaging Machines

Innovative Packaging offers a range of filling and packaging machines for granules, powders, liquids, viscous liquids, high viscous liquids. The range includes: Powder filling machine, Liquid Filling and Capping machine, Mini sachet packer, automatic 8 head mango pulp filling line, etc.

Contact:

Innovative Packaging Machines

Plot No: 232, Sector No: 10, PCNTDA Bhosari

Pune, Maharashtra 411 026

Mob: 95610 65107 • E-mail: sales@ipackmachines.in

Laser Marking Service

Scripts & Marks provides Laser marking service, which includes Design, Marking and Delivery. The Company is specialised in rotary scale marking, customised linear scale marking, copper and graphite electrode engraving. Maximum engraving and marking area 20" x 12" x 9" (max weight 75 kg). It is a permanent marking solution. Metals with varied hardness like HSS, Carbide, D2, Graphite, Silver, Gold, Brass, Plastics and Bakelite, etc. can be marked. Laser applications: Gauges, Name Plates, SS Dinner plates, Jewellery, Electronic Components, Medical Instruments, Engineering Plastics, Buttons, Integrated chips (IC) Hardware tools, Gift articles like Key Chain, Pens, Rings, etc.



Contact:

Scripts & Marks

23 Opp: Ramnagar Primary School, Malavia Street

Ram Nagar, Coimbatore, Tamil Nadu 641 009

☎ 0422 – 436 9234 • Mob: 91597 55234

E-mail: scriptsandmarks@gmail.com

High Quality Precision Moulds and Components

Vasantha Tool Crafts Pvt Ltd is an established manufacturer of high quality precision moulds and components. The Company has successfully designed and manufactured over 2000 high cavitation critical precision moulds

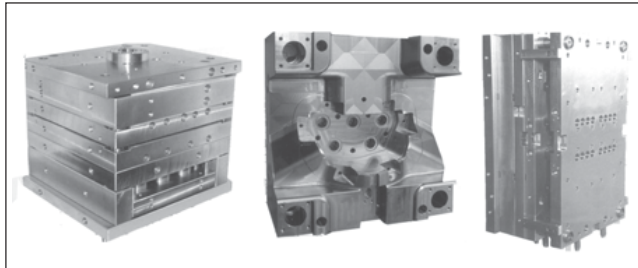

with various features. Some of these are, high cavitation Bi-Component hot runner injection moulds with in-mould closing (IMC) features for various applications such as cap

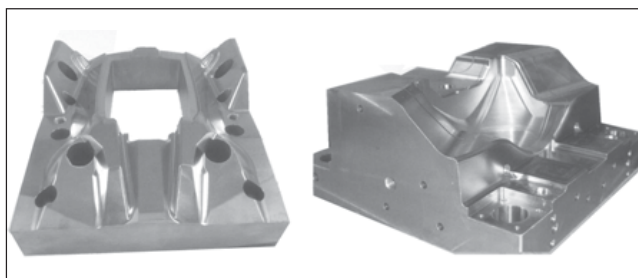

and closures for FMCG, pharma, and health care segments. Their services include: Product Design, Prototyping, Mould Flow Analysis, Mould Design, Mould Manufacturing, Mould Testing and Qualification, and Laser Sintering.

Contact:

Vasantha Tool Crafts Pvt Ltd

7-24/2 Pipe Line Road, Subhash Nagar

Jeedimetla, Hyderabad, Telangana 500 055

☎ 040 – 4461 3333 • Fax: 040 – 2309 7023

E-mail: info@vasanthatools.com

Drill Bushings & Machined Components

Mac Machine Products Pvt Ltd offers Drill Bushings and Machined Components like Standard Bushings, Special Bushings and Automotive Production Components. Ma-



terials offered: Through hardened steel; Case hardened steel; Carbide steel; Stainless steel; HSS; Phosphor Bronze; Brass, etc. Surface Finish: ID Honed/OD Ground. Bore size: 1.2 to 120 mm.

Contact:

Mack Machine Products Pvt Ltd

F-134, 1st Street, Anna Nagar East, Chennai 600 102

☎ 044 – 4862 7676 • E-mail: sales@mackproducts.in

Plain Plug Gauges – Tieco Brand “Measuring Technology on the Right Track”

Jayesh Enterprises has been manufacturing high quality TIECO brand Plug gauges for the last 40 years. Plain Plug Gauges are used to check small and big bores. They are available from 0.3 mm to 460 mm as per I.S: 3455:1971, BS: 969:1963 and JS Standards. The gauges are calibrated in their ISO/IEC19025:2017 certified by NABL laboratory at 20°C using the latest TRIMOS length measuring instruments and QMSOft© software. The Company’s other products include: thread gauges, taper gauges, ring gauges, snap gauges and special gauges.



Contact:

Jayesh Enterprises
103 First Floor, Ramtekdi Industrial Area
Hadapsar, Pune, Maharashtra 411 013
Mob: 91588 66112, 91588 66113, 91588 66114
E-mail: jawssales@jawsindia.com

Vertical Turret Milling Machine

S&T Engineers offers Vertical Turret Milling Machine Model IV400. Its features: X/Y/Z travel: 830/380/355 mm (32.7"/15"/14") ; Spindle nose to table surface: 100-506 mm (4"-20"); Spindle center to column surface: 159-719 mm (16.2"-28"); Table size: 1370 x 250 mm (54" x 10"); Table T-slot (No x size): 3 x 16 mm (3 x 0.63"); Max table load: 350 kg (771 lbs); Spindle taper: NST #30/R8; Spindle speed: 5000 RPM (60 Hz); Quill feed: 0.04~0.08~0.14 mm; Transmission: Variable speed (Opt inverter); Quill travel: 127 mm (5"); Over Swivel on Turret: 360°; Head Swivel (R&L): ±45°; Head swivel (Up and Down): ±45°; XY Feed Rate: 0-3 m/min (0-0-12"); Rapid feed rate XYZ: 5 mm/min (0.2"/min); Spindle motor: 3 HP; XYZ motor: 1 kW AC Servo Motor; XYZ transmission: 1:2 belt; Coolant pump: 1/8 HP; Machine size – Overall width: 1900 mm (75"), Overall depth: 2087 mm (82"); Overall height: 2120 mm (83.5"); and Net weight: 1400 kg (3,087 Lbs).



Contact:

S&T Engineers (P) Ltd
22 Vasanth Nagar, Singanallur
Coimbatore, Tamil Nadu 641 005
☎ 0422 – 259 0810 • Fax: 0422 – 257 3629
E-mail: info@stengineers.com

Aerosol Generator

Measuretest Instruments offers a wide range of Aerosol Generator. Features are: the 4B series family of Laskin-Nozzle aerosol generators are durable, portable, and reliable; designed for testing filter systems ranging from small glove boxes to large cleanroom plenums, ATI Laskin Nozzle generators provide the ideal solution for creating a polydispersed, submicron aerosol to certify and qualify in-situ filter systems; aerosol concentration output varies by generator model; however, concentrations can be achieved from 100 µg/l down to 10 µg/l at airflows ranging from 405 to 8,100 CFM. The company is authorized distributors in India for American, British and Japanese manufacturers of scientific, analytical and process control instruments. Measuretest specialises in cleanroom monitoring equipment for the pharmaceutical, electronics and automobile industries.



Contact:

Measuretest Instruments
B-23, 1st Floor, Narayan Plaza, Next to Chandivali Road
Yadav Nagar, Chandivali, Powai, Mumbai 400 072
☎ 022 – 4970 1393 • E-mail: info@measuretest.com

TECHNICALLY RELIABLE PRODUCTS

We Design Drives, Manufacture Pulleys In All Pitch For Timing Belts Hob Cut With Imported Cutters Conforming To International Standard, Special Vee Belt & Flat Belt Pulleys & Any Belt Pulley As Per Drawing.

We Deal in Imported:

- Timing Belts • Flat Tangential Belts • Wedge-space Saver Belts
- Nylon Sandwich Belts • Conveyor Belts • Poly 'V' Belts
- Endless Belts • Poly Flex Belts • Catter Pillar • Perlon Ropes & Any Special Belts are manufactured as per Client's Requirement.



TRP
kwedos
Belt Drives



B-2, Alaukik Flats, Near Dwarkesh Tower, Judges Bungalows Road,
Bodakdev, Ahmedabad 380 015.
Mobile : 99251 11749 • Telefax: 079 - 2687 0311
E-mail: sales@kwedos.com / info@kwedos.in

Automated Welding

Welding being a conventional process requires a different approach than standard automation. The criticality is not only in manipulation but achieving the parameters as per the WPS. Maintaining the heat input and angles are skilled activity and not simple. The years of versatile experience in this field is what helps Keepsake stand-out in the market. Principles of welding: Creation of welding arc; Directing the high temperature arc towards the fusion zone; Impact of the energy causes fusion of the parent material and form weld pool; Molten pool is shielded by the insert gas/floating slag. Types of Welding: Gas Metal Arc Welding (MIG); Gas Tungsten Arc Welding (TIG); Plasma Transfer Arc Welding (PTAW); Friction Stir Welding. Automation and Services: Welding Solutions; Cutting Solutions; Handling Solutions; Cladding Stations; Robotic System Integrators; Turnkey Automation Projects; Robotic Simulation; and Fixturization.

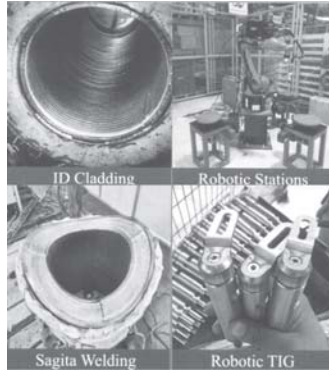

Contact:

Keepsake Automation LLP
1st Floor, Keepsake Welding Research Centre
LD College of Engineering Campus
Navrangpura, Ahmedabad, Gujarat 380 015
☎ 079 – 2630 7576 • E-mail: info@keepsakeautomation.com

Bearing Puller Interchangeable Tip

Orient Hardware & Tools Corporation offers a wide range of Bearing Puller Interchangeable Tips. Features are: its jaw made of high quality forged alloy steel; tripod made of high quality carbon steel; it is special overall heat treated for durability; claws and tripod well designed to withstand high torque; changeable tip; it is available in both two and three jaw; its sizes available 4", 6", 8" and 10"; and its application includes: can be used for external as well as internal bearings; remove pulleys and bearings from shafts and cavities.



Contact:

Orient Hardware & Tools Corporation
264 Dr Nanjappa Road, Anupperpalayam, Ram Nagar
Coimbatore, Tamil Nadu 641 018
☎ 0422 – 4072 242 • Mob: 76391 54777
E-mail: sales@orienthw.com

Pulp & Paper Stock Pumps

Keerthi Pumps, an ISO 9001-2008 Certified Company supplies Pulp and Paper Stock Pump Type PS. Its Salient features: Back pull out design; Steady flow; High efficiency; Sturdy Construction; Low NPSH; Noise and Maintenance free; Environment Friendly; Shaft Deflection Below 0.05 mm; Simple External Axial Adjustment for Impeller Wear and Tear; to pump the pulp as like water. MOC: Graded Cast Iron, 2% NiCl, WCB, CA-15, SS 304, SS 316, SS317L, CD4MCuN, Alloy 20. Operating Range – Capacity: Up to 2500 m³/hr; Head: up to 80 m (262 feet); Temperature: Up to 140°C; Casing Pressure: Up to 22 kg/cm²; Pump size: DN 80 mm to DN 400 mm; Speed: up to 1750 rpm; Direction of rotation: Clock wise from Drive End. Applications: PS Type pumps are used in Paper and Pulp industry, Food industry, Sugar industry, Effluent Plants, Sea Water Desalination Plants, Power Stations, Chemical and Petrochemicals industry, Power Stations and Absorption Plants in Environmental Engineering, etc. Handling of Pulp and Paper stocks up to 7% consistency heavily contaminated liquids, raw sewages, Chlorinated water, etc.

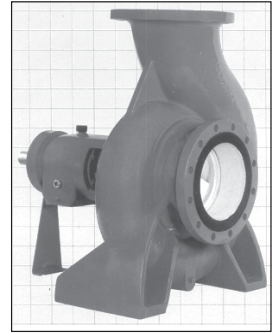

Contact:

Keerthi Pumps
1/514 Anna Nagar, Avinashi Road, Neelambur Post
Coimbatore, Tamil Nadu 641 062
☎ 0422 – 653 6341 • Mob: 98430 62938
E-mail: keerthipumps@gmail.com

Bag Filter

Universal Precision Tools offers Bag Filters, which are manufactured in simplex, duplex and multiplex types. These are produced in carbon steel and stainless steel. The duplex system is supplied with complete change over valves and differential pressure gauge with chocking indication for the replacement of filter element or bag. The working pressure will be from 0-100 bar and level of filtration 1 micron to 800 microns, viscosity ranging 1 cps to 60,000 cps. The application is in chemical and machine tool industries for filtration of industrial coolants, hydraulic oils and lubrication oils.



Contact:

Universal Precision Tools
Plot No: 42/3B, M.T. Sagar Industrial Estate
Gokul Road, Hubli, Karnataka 580 030
☎ 0836 – 233 3383, 233 1598
Fax: 0836 – 233 2472
Mob: 93434 01999 • E-mail: upt@alpha.net

Blow Moulding Machines

Central Machinery & Plastic Products manufactures Blow Moulding machines that are suitable for manufacturing Containers in PVC, HDPE, LDPE, PETG and PP materials from 5 ml to 100 ltrs.

Salient Features of Model CMP.1000/D/E/1: Fully automatic; Continuous Parison; Simple to operate; More versatility; Great reliability in production infinitely variable speed AC drive with high output. Choice of single or double station with or without De-Flashing machines in different models with options of: Double Head; Bobbing Extruders; Viewing Strip Machines; Hot Wire-Cutter; Bottom Blowing System; Angular Blowing Attachment; Multi Point Parison Control; Extruders with Bigger Screws.

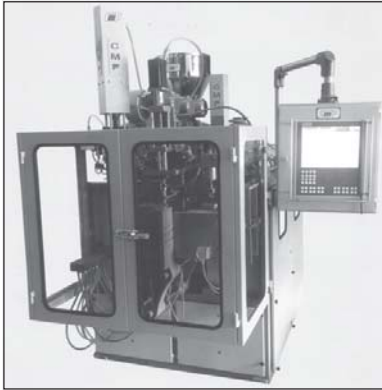

Contact:

Central Machinery & Plastic Products
Aristocrat, B-3, Lajya Estate, Mogra Road
Andheri East, Mumbai 400 089
☎ 022 – 2836 6198, 2822 0792
E-mail: cmp@cmppin.com

Iron Worker

Sanmac Machines supplies Sunrise Ironworker K-series manufactured by Sunrise Fluid Power Inc of Taiwan. It is a special designed compact ironworker with vertical movements at all stations. The entire man slide moves in straight up and down motion to provide the optimum results for punching, shearing, notching, and bending. Optional hydraulic hold-down and urethane spring stripper are also available for the best performance. The very fast cylinder stroke greatly improves the efficiency. This model incorporates versatility, efficiency, accuracy, and ease of use at an excellent price. Capacities and Specifications of Model IW-85KD – Punching pressure: 85 ton; Maximum Capacity: dia 27 x 22 mm; Throat Depth: 410 mm; Flat Bar Shear (W x T): 406 x 20; Angle Shear: 130 x 130 x 12; Round Bar Shear: dia 45 mm; Square Bar Shear: 45 x 45 mm; Channel Shear (optional tooling): 152 mm; Rectangular Notcher (W x D x T): 63.5 x 90 x 12 mm; Motor Power: 10 HP.

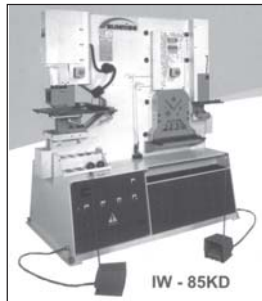

Contact:

Sanmac Machines
169 Second Floor, Vakil New Street
Madurai, Tamil Nadu 625 001
Mob: 94430 50170, 94430 30170
E-mail: admin@sanmacmachines.com

CNC Engraving & Milling Machine, Model Velocity VX-4535

Sunita Engineering Corporation manufactures a range of CNC Milling and Engraving machines. Technical Specification of Velocity VX-4535 – Table size: 560 x 460 mm; Clamping area: 500 x 400 mm; T-slots – a) 4 Number, b) Centre distance: 110 mm, c) Size: 12 mm; Maximum safe load on table: 100 kg; Distance from table to spindle face (customizable): 150 mm; Axis travel – 1) X-axis: 450 mm, 2) Y-axis: 350 mm; 3) Z-axis: 80 mm; Axis motion: through pre-loaded ball screws and hardened and ground LMGs; Axis drives: Servo drives; Cutting feed rate: 3000 mm/min; Rapid traverse: 5000 mm/min; Positional accuracy: 0.005 mm; Repeatability: 0.005 mm; Spindle type: high frequency; Spindle motor power options available: 2.2 kW; Max spindle speed: 24,000 rpm; Spindle nose taper: ER 20; Maximum tool size: 12 mm; Floor space (L x W x H): 1200 x 1500 x 1700 mm; Net weight of machine: 400 kg; Power requirement 3.5 kW, Single phase AC, 230 V, 50 Hz.

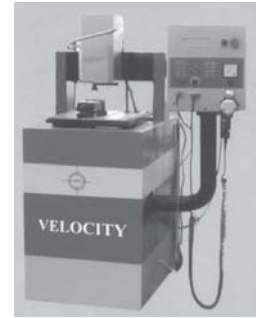

Contact:

Sunita Engineering Corporation (SEC)
D-3 MIDC, Ambad, Nashik, Maharashtra 422 010
Mob: 77219 41115, 77219 41116
E-mail: nnk@secengraving.com

Manufacturers of:
Heat Exchanger, Condenser Chiller, Aftercooler, Intercooler, Economiser etc, Finned Tubes: (Spiral Tension Wound Continuous) in Crimped, Plain 'L' Base, 'G' etc. Type Fins, Radiator, Air Cooler, Oil Cooler, Steam/Oil Heater etc, Pressure/Reaction Vessels Receivers & Storage Tanks.

Heat-Cool **HEAT COOL FIN INDUSTRIES**

Plot No: 1002/2 E, IV Phase, G.I.D.C. Estate, Vapi 396 195 (Gujarat)
Tel: 242 3047, 242 8399 • Telefax: 0260 - 243 1166, 242 8399
Mobile: 98241 30918, 93770 03336 • Website: www.heat-coolfin.com
E-mail: heatcool@rediffmail.com / heatcoolvapi@gmail.com

Turbine Blades & TG Components

EM Services (I) Pvt Ltd is supporting utilities having imported TG sets in indigenising Critical Turbine Components at low cost with OEM Quality Standards. Some of the



components manufacture are: Special Alloy Fasteners like Stud, Nuts, Bolts, etc; Packing Rings, Seal Rings, Labyrinth Seals, etc; Cone, Stems, Seats, Bushings for Turbine Valves; Spill Strips, Peak Seals for Diaphragms; Impellers, Discs, and other Pump Components. Some of the prestigious orders received/executed are: LP Rotor L-1 Stage Blades of 210 MW Turbine of KWU Design; LP Rotor 5th and 6th stage Blades and IP Rotor 1st - 4th stage Blades of 120 MW BHEL make; LP Rotor 8th stage Fixed and Moving blades of 140 MW Turbine CEM France make; HP and LP Moving blades for all stages (1-17) of 62.5 MW GE (USA) make Turbine Rotor; Nozzle Block and Diaphragms stage 2 to 8 for 62.5 MW GE (USA) make turbine; Compressor moving Blades for V 94.2 Siemens GT.

Contact:

EM Services (I) Pvt Ltd
K-4, Five Star Industrial Area, MIDC
Butibori, Dist: Nagpur, Maharashtra 441 122
Mob: 93732 89420, 99307 75009
E-mail: info@emservicesindia.net

Vertical Pressure Leaf Filter

Sruthi Agro Process offers Vertical Pressure Leaf Filter for filtration of liquids with solid content up to 5 to 7% in edible oil, chemical, food and pharmaceutical industries. Areas up to 75 m² with dry or wet cake discharge. The Company also offers Tubular Centrifuges, Horizontal Pressure Leaf Filters, Sparkle Filters, Polishing Filters, Candle Filters, etc.



Contact:

Sruthi Agro Process
11 Modern Ind Estate, Walive Phatta, Sativali
Vasai (East), Palghar, Maharashtra 401 208
☎ 0250 - 320 8273, 248 1095
E-mail: sruthiagro@rediffmail.com

Y Strainers Fabricated

Sungov Engineering Private Limited offers Y Strainers Fabricated for Solid-gas, Solid separation. Salient features: Dimensional and design flexibility; High flow rate handling

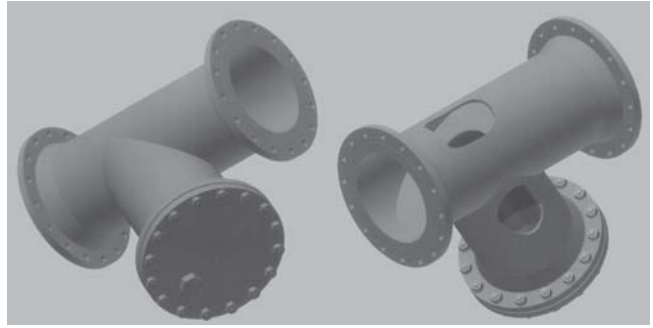

capacity; Customized cover design for easy service. Design Features: Generous gross filter area for low pressure drop; Built to ASME Sec VIII Div 1/B31.3 standards; Vessel design for vacuum as option. Stock Housing Materials of Construction: ASTM A 106 Gr. B; ASTM A 105; ASTM A 312 TP304; ASTM A 182 Gr.F304; ASTM A 312 TP316; ASTM A 182 Gr.F316; ASTM A 240 Type 304/316. Filter Element Materials of Construction: Austenitic stainless steel; Austenitic-ferritic stainless steels; Nickel alloys; and Copper alloys. On-order Housing Materials of Construction: Other Carbon steels; Other low temperature carbon steels; Low alloy steels; Martensitic stainless steels; Austenitic-ferritic stainless steels; Nickel alloys; Copper alloys. Filter Ratings: 150 um to 8000 um; Size: up to 30"; End connections: Flanged; and Butt Weld. Pressure Ratings: Up to ASME #2500; and up to API6A 15K. Industries used in Oil and gas; Marine; Power Generation; Chemicals Manufacturing; Environmental; Metals Mining; Industrial Utilities; and Aviation.

Contact:

Sungov Engineering Private Limited
K27 Ambattur Industrial Estate, Chennai 600 049
☎ 044 - 2635 9940 • Fax: 044 - 2650 1408
E-mail: exportsales@sungov.com

Packing Machines

Ace Pack Machines offers Packing Machines Type Collar, Auger Type for Powder packing and Cup Type for granules and Weigh Filling for granules and Chips, Snacks, etc. Packing range: 5 g to 2 kg; Packing speed: 50-100 pouches/minute; Power: 3.25 HP + 2500 W heater, 3-phase, 415 V power supply.



Contact:

Ace Pack Machines
23 V N Industrial Estate, Bharathi Colony
Peelamedu, Coimbatore, Tamil Nadu 641 004
☎ 0422 - 256 8212 • Mob: 93632 48100
E-mail: acepackmachines06@gmail.com

CNC Wire Abrasive Cut Machine, FQT Series

Fostex India Pvt Ltd offers CNC Wire Abrasive Cut Machine, FQT Series, which is widely used for cutting graphite electrodes, epoxy plate, hard alloy, marble, jade, optical glass, ceramics, ferrite, semiconductor materials, carbonized silicon and other non-conductive material. Features: Integrated programming and control software; Graphite tracking; Arbitrary angle rotation; Symmetric machining; Wire broken protection; Automatic power off after finishing job; USB port for inputting dxf drawing; Forward and reverse processing; Analog Processing. Specifications of Model FQT-2532 – X travel: 250 mm; Y travel: 320 mm; Working table: 580 x 400 mm; Max load on table: 250 kg; Max cutting thickness: 250 mm; Abrasive wire dia: 0.18-0.35 mm; Movement for hand wheel per cycle: 1 mm; Pulse equivalency: 0.001 mm; Roughness: 0.8~2.0 Ra; XY motor: Stepper motor; Max cutting speed: 100 mm/m/in; Power: 2.0 AC 415 V/50 Hz, 3 phase; Weight: 1000 kg; Machine Dimension: 1450 x 1000 x 1600 mm; Control cabinet Dimension: 750 680 x 1650 mm; Software: HL/HF/Autocut software; Control cabinet: vertical.



Contact:

Fostex India Pvt Ltd
Bhairavnath Industrial Estate, Gat No: 2/1, Plot No: 15
Nr: Choudhary Weighing Bridge, Dehu-Atlandi Road
Chikhali, Pune, Maharashtra 411 062
Mob: 93726 23735, 95031 31666
E-mail: infoberlinmachine@gmail.com

Buttweld/Socket Weld/Screwed Fittings

Inter-Tech Fittings India Pvt Ltd manufactures Buttweld/Socket Weld/Screwed Fittings. The products range includes: LR/SR Elbows; 3D/4D/5D and any Special Radius band; Equal/Unequal Tee, Cross Tee; Concentric/Eccentric Reducer; Stub end; Cap, Cap, Coupling, Nipple, Union, Bushing, Plug, Swage Nipple; Weldolet, Sockolet, Laterolet, Thredolet; Elbowlet, Nippolet; Flange – SOIRF, WNRF, BLRF, T&G. Inter-Tech Fittings India is a growing company engaged in manufacturing, marketing and Exporting all types of Steel Pipe Fittings and Flanges as per International Standard.



Contact:

Inter-Tech Fittings India Pvt Ltd
Plot No: AM-12 P, Additional MIDC
Anand Nagar, Ambernath (East), Maharashtra 421 506
☎ 0251 – 262 1181, 319 1181 • E-mail: vtc0494@gmail.com



V.V.MUJUMDAR & ASSOCIATES

AN ISO 9001-2008 Certified Co.



FLEXIBLE COUPLINGS For CNC Machines, Encoders



PRECISION LOCKNUTS For Ballscrews, Spindles



ROLLED BALL SCREWS

From dia 16mm-80mm • Length upto 6 Mtrs standard
For SPMS, Automation, Robotics, Material Handling

We also undertake Repaires & Servicing of Ballscrews

Plot No. T-165/1/25, Priyadarshini Co-Operative
Industrial Society, Near Post Office, MIDC, Bhosari,
Pune - 411 026, Maharashtra

Telefax : 020 - 27129820

Mobile : 9766626745

Email : vvmujumdar@gmail.com

Web : www.vvmujumdar.com

Double Column Bandsaw Machine Model LMG 200 H (Semi-Automatic)

Multicut Machine Tools, an ISO 9001: 2008 Company offers a semi-automatic Double Column Bandsaw Machine Model LMG 200 H. Technical Data: Cutting capacity – Round bar: 200 mm; Square bar: 200 x 200 mm; Main Drive motor: 1.5 HP (1440 RPM); Hydraulic motor: 0.5 HP (1440 RPM); Coolant motor: 0.13 HP; Total Power: 2.13 HP; Vice Clamping: Hydraulic; Band Tension: Manual; Blade size: 3760 x 27 x 0.9 mm; Cutting speed: 24-76 m/min; Hydraulic tank capacity (approx.): 15 litre; Coolant tank: 20 litre; Floor space (approx.) L x W x H: 1800 x 600 x 1250; Net weight: 850 kg. Applications: Cutting of Mild Steel, Ferrous-non-ferrous Alloy steel, Stainless steel, Brass, Copper and aluminium, Round bar, Square bar, Rectangle, Foreign billets, Pipes, Flat, Angles, Channels, Columns and structural steel, etc.

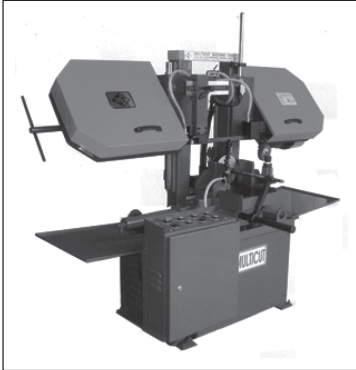

Contact:

Multicut Machine Tools
359/B-360-2, GIDC, Makarpura
Nr: Hanumanji Temple, Baroda, Gujarat 390 010
Telefax: 0265 – 264 0809
Mob: 98796 11699
E-mail: sales@multicut.in

CNC Internal Cylindrical Grinding Machine, Model ICG-100

Sharda Mechanic Works Pvt Ltd manufactures CNC Internal Cylindrical Grinding Machine, Model ICG-100. Specifications: Capacity – Maximum grinding diameter: 200 mm; Minimum grinding diameter: 5 mm; Maximum grinding length: 100 mm. Control System: Fancu/Siemens; Work Head – Spindle speed (variable): 300-1250 rpm; Swivelling range: -5 to 60 deg; Motor Power: 1.5 kW; Internal Grinding Wheel Head – Spindle speed (belt driven): 18000 rpm; Motor power: 3.7 kW; Optional spindle (Belt driven): 10000/12500/15000/22400/28600 rpm; High frequency spindle (optional): on request; Axis (X and Z) – Rapid feed rate: 10 m/min; Resolution: 0.001 mm.

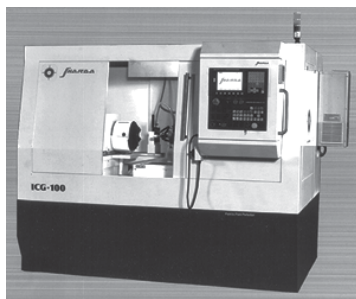

Contact:

Sharda Mechanic Works Pvt Ltd
Dudharej Road, Surendranagar, Gujarat 363 001
☎ 02752 – 254 775 • Mob: 98257 77003
E-mail: sharda@shardamachines.com

Paper Straw Making Machine

Sahil Graphics offers Paper Straw Making Machine Model PS-500, which is suitable for producing different sizes of paper straws, such as 5 mm, 6 mm, 8 mm, 10 mm, 12 mm, etc, with latest design for cutting device with 5 cutting knives. The stable working speed is 40-50 m/min. Salient Features: Adopted with human-machine operation interface. The main motor is equipped with variable frequency drive for easy parameters setting and operation. Paper reel stand, slitted rolls are easily placed into reel stand by electric lifting device. Choose from single or double glue coating unit; Spiral winding part; hanging type operating panel, specialized operation system, belt tension device (hand wheel driven). Multi-knife system for in-line cutting unit controlled by encoder thus cutting final paper tube directly. Main parts: Servo motor and inverter all of Schneider brand, pneumatic components is of Air TAC brand, which



gives very stable performance. Technical Specifications – Paper Layer: 2-5 Layer; Inner diameter: 4.0-12.0 mm; Thickness of straw: 0.3-1.0 mm; Speed: 150-200 straws per minute (using 5 cutters); Cutting System: Programmable control with Multi Knife; Cutting Length: 120-1050 mm; Synchronous Tracking and Cutting: Servo Motor Synchronous Tracking Cutting; Way of gluing: Single/Double; Fixed Length Way: Encoder; Speed Control: Pole free Speed Regulation; Fuselage Parts: 380 V/3-phase/50 Hz; Glue System: three layer spray Type; Interface: Schneider; Bearing: HRB; Servo Moor: 1 kW Schneider; Total Power: 9.6 kW; Dimension (L x W x H): 8000 x 6000 x 1800; Machine weight (approx.): 1200 kg.

Contact:

Sahil Graphics
Plot No: 62, Sector-59, HSIDC Industrial Estate
Faridabad, Haryana 121 004
☎ 0129 – 230 9200 • Mob: 99717 89988
E-mail: info@sahilgraphics.com

Steel Pipes & Tubes

Dugar Tubes Ltd supplies all kinds of Mild Steel Pipes and Tubes (Seamless, ERW, Hydraulic and Boiler Tubes) in various specifications ie ASTM/API/ISI/DIN to meet unforeseen and urgent demands of customers.

Contact:

Dugar Tubes Ltd
409 Crystal Paradise The Mall, Off Veera Desai Road
Andheri (W), Mumbai 400 053
☎ 022 – 2674 0701, 2674 0702
E-mail: sales@dugartubes.co.in

Industrial Products Source

A Magazine for Indian Industries since 2004

SPECIAL SECTION SCHEDULE - April 2021 to March 2022

April	2021	Pumps & Valves, Pneumatics & Hydraulics, Chemicals & Petrochemicals, Process Plant & Machinery
May	2021	IMTEX 2021 Exhibition + Focus: Machine Tools & Accessories
June	2021	Foundry Equipment, Casting, Forging & Shot Blasting, Boilers & Furnaces
July	2021	Gears & Bearings, Motors & Drives, Clutches & Brakes, Oils & Lubricants
August	2021	Automation 2021 Exhibition + Focus: Instrumentation, Industrial Automation Testing & Measuring Instrument
September	2021	Pumps, Valves, Tubes & Pipe Fittings
October	2021	Material Handling & Storage Equipment
November	2021	Electrical & Electronics, Solar, Wind & Alternative Energy
December	2021	18 th Annual Issue + IMTEX 2022
January	2022	Chemical, Pharma, Bio-Tech & Food Processing, Packaging, Pollution Control Equipment + CHEMTECH 2022
February	2022	Cables, Wires, Connectors Control Panels Transformers, Switchgears & Welding Equipment
March	2022	Machine Tools, Auto Components Accessories + Diemould Exhibition 2022



Area of Circulation (Industry wise)

- Agriculture
- Air Condition
- Airlines & Aerospace Industries
- Atomic Sector
- Automation
- Automobile
- Bio-Tech & Pharmaceuticals
- Boilers
- Banking Sector
- Cement
- Ceramics
- Chemical Plants
- Construction Machinery & Equipment
- Defence
- Electrical & Electronics
- Exporters
- Fasteners
- Fertilizer
- Food & Beverage
- Foundry & Forgings
- Heat Exchangers & Cooling Towers
- Heavy Engineering
- Hydraulics & Pneumatics
- Industrial Safety & Security
- Libraries
- Machine Tools
- Material Handling
- Oils & Refineries
- Paints
- Paper & Pulp
- Petrochemicals
- Plastic & Rubber
- Pollution Control Boards
- Printing & Packaging
- Project Consultants
- Pumps & Valves
- Railways
- Research Institutions
- Steel
- Sugar / Tea
- Testing Laboratories
- Textiles
- Universities
- Welding

Advertisement Tariff

Size	4-Color	Black & White
Full Page (17.5 [W] x 25 [H] cm)	₹ 21,000/-	₹ 14,000/-
Half Page (H-17.5 [W] x 12 [H] cm) (V-8.5 [W] x 25 [H] cm)	₹ 12,800/-	₹ 8,500/-
Quarter Page (8.5 [W] x 12 [H] cm)	₹ 7,200/-	₹ 4,800/-
Double Spread (35 [W] x 25 [H] cm)	₹ 42,000/-	₹ 28,000/-
Cover Pages		4 - Color
Front Cover-Half Page (H)	₹ 24,000/-	
Front Cover-Quarter Page	₹ 15,000/-	
Front Cover-Strip (H) (17.5 [W] x 6 [H] cm)	₹ 15,000/-	
Front Inside Cover	₹ 27,000/-	
Back Inside Cover	₹ 27,000/-	
Back Cover	₹ 32,400/-	
Front Gate Fold	₹ 54,000/-	

Home Page	3-Months	6-Months
Small Banner (100 x 100 pixels)	₹ 6,000/-	₹ 10,000/-
Large Banner (240 x 100 pixels)	₹ 8,000/-	₹ 14,000/-
□ Inclusive of Design & Hosting - 12 kb maximum □ If the advertiser wishes to change the design or any updating in the banner will be charged extra		

1-Year (12 Issues)	₹ 300/-	Subscription Charges
2-Year (24 Issues)	₹ 550/-	
3-Year (36 Issues)	₹ 750/-	

Outstation payment should be at par cheque/DD drawn in favour of "Product News Publication" only

Trim Size: 28 [H] x 21 [W] cms; Bleed Size: 28.6 [H] x 21.6 [W] cms Material Requirement: CorelDraw or PDF Files



Editorial, Circulation & Marketing Office

Product News Publication

104, Sudama Yash, Nr: Ramkrishna Hotel, Kelkar Cross Road, Ram Nagar, Dombivli (E), Thane 421 201
Tel: 0251 - 286 1351 • E-mail: ipsmaginfo@gmail.com / ipsmag@yahoo.com

Visit: www.ips.co.in / www.industrialproductssource.com to view our e-magazine

MEBA – Bimetal S

AB Corporation supplies MEBA – Bimetal S, which is a best performance Bandsaw blade with wear resistant M42. HSS positive rake angle, which ensures high performance and long service life with high cutting accuracy of thin or medium materials.

Advantages: Increased cutting accuracy and wearability by alloyed high cutting steel with 8% cobalt and 10% molybdenum. Increased edge life

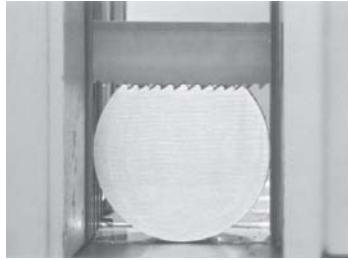

comparable for Bi-metal saw blade. Range of applications: for steel up to 45 HRC; for all work piece dimensions; for serial cuts in automatic operation; for bundle cuts of large work piece dimensions and solid material; for nonferrous metals and fine steel profiles.

Contact:

AB Corporation

19 Ramar Kovil Street, 1st Floor

Ram Nagar, Coimbatore, Tamil Nadu 641 009

☎ 0422 – 420 3464 • Mob: 97872 11004

E-mail: abcorporation2003@gmail.com

CNC Polygon Turning Machine

Brisk CNC Polygon Turning Machine is a high precision and rigid construction to cater to a wide variety of machining needs. Wide cutting applies to even number polygon cutting (flat, square, hexa-

gon), eccentric cutting, radius, chamfer, taper profile cutting, etc. Specifications of Model PTFL-50: Capacity – max turning diameter: 50 mm; Max turning length: 100 mm; Maximum Hex milling length: 100 mm; Distance



between center: 200 mm; Spindle – Max speed: 3000 rpm; Spindle nose: A2-5; Spindle Bore: 50 mm; Bar capacity: 25 mm; Rapid feed X, Y, Axis Rapid Traverse: 20 m/min; Guideways: X and Z axes: Roller; Stroke – X axis stroke: 170 mm; Z axis stroke: 190 mm; Turret – Cutter Type: SERVO; OD Tool Shank: 20 x 20 mm; ID Tool Shank: 20 mm; Cylinder – Hydraulic Chucking Cylinder: P80; Chuck – Collet chuck: A-42; Motors – Spindle motor: 5.5 kW; Live Tool Spindle – 2.2 kW; Servo motor X axis – 1 kW; Servo motor Z axis: 1.2 kW; Hydraulic pump: 0.75 kW; Lubrication pump: 0.12 kW; Coolant pump: 0.1 kW; Machine size – Length: 2500 mm; Width: 1700 mm; Height: 1800 mm; and Gross weight: 3500 kg.

Contact:

Brisk Tech Engineers

No: 3, 14th Cross, 2nd Main, Bhyraveswara Indl Estate

Peenya Second Stage, Bangalore, Karnataka 560 091

☎ 080 – 2836 4403 • Mob: 94484 79855

E-mail: info@brisktechengineers.com

Bimetallic Barrels

Kaivanya Extrusion Technik offers Bimetallic Barrels dia from 25 mm to 200 mm and length up to 6000 mm. Barrels are processed with bimetallic alloy hard face coating have



many virtues, such as high hardness, stronger wear and corrosion resistance. Its general properties are three to fifteen times more compared to the nitriding steel. They are widely used for highly abrasive and corrosive materials like engineering polymers and PVC compounds. The main machining methods are as follows: spot spray, spray coating, cover coating, mould, butt welding, etc. The bimetallic process used in world as advanced technology for better life with consistent production and quality. It is the best choice for production special screws. Polymers can be used: Minerals, Glassfibers, Pigments, and Carbon fibers.

Contact:

Kaivanya Extrusion Technik

2905 Phase IV, GIDC, Vatva, Ahmedabad, Gujarat 382 445

☎ 079 – 2273 0465 • Mob: 99798 79160

E-mail: kiran@kaivanyaextrusion.com

Hot Stamping Machine for Round Objects

Velpro Technologies manufactures Hot Stamping Machine for Round Objects. Its advantages are: Each part is custom design; Timer base foiling system to achieve accurate result; Automatic foil winding; Fast production; and Easy installation. Specifications – Voltage: 230 V; Weight: 450 kg; H x W x L: 5.5' x 3' x 3'; Grade: semi-automatic; Operating system: pneumatic; Air pressure: 5-8 psi; Heating range: room; Temperature: 350°C. Applications: Heat transfer or foiling on round articles; can print any plastic round article up to 10 lit; VTRS-150s can print flat surface also e.g. molecular switches; VTRS-150s use for foiling on pet bottles, household items, small buckets, jars, mugs, containers, casseroles, etc.

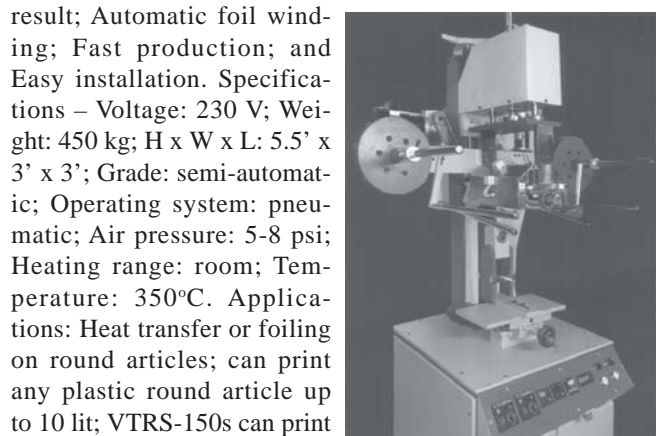

Applications: Heat transfer or foiling on round articles; can print any plastic round article up to 10 lit; VTRS-150s can print flat surface also e.g. molecular switches; VTRS-150s use for foiling on pet bottles, household items, small buckets, jars, mugs, containers, casseroles, etc.

Contact:

Velpro Technologies

B-2 Navpada, Farooque Compound

Marol Naka, Andheri East, Mumbai 400 069

Mob: 7397939690 • E-mail: contact@velpro.in

Power Cables

Empire Cable supplies power cables with PVC insulation for power transmission. Voltage grade 650/1100 volts (Uo/U) provided with ISI marking IS 1554 (Pt-1), with or without HR/FRLs properties. Scre-ening can be provided if desired. The cables conform to standard specifications like IS 1554 (Pt-1), IEC 502, BS 6436/87. Configuration: Single core up to 1000 sq mm, multi-core up to 400 sq mm x 3-1/2 cores; Construction: Conductor is aluminium/copper, solid/stranded circular/compacted/sector shaped. Insulation is PVC; Mechanical protection: Galvanized steel wire/strips/double helical steel tape; aluminium wire amounting for single core cable; Inner and outer sheath – PVC black/grey or as per requirement.



Contact:

Empire Cable Industries (P) Ltd
Plot No: 115, Phase-II
Badli Industrial Area, Delhi 110 042
☎ 011 – 2387 4632 • Fax: 011 – 2386 1610
E-mail: empircables@yahoo.co.in

Spur Gears

Covaai Gears offers a qualitative array of spur gears that are available in different sizes and dimensions as per the needs and requirements of end users. These spur gears are easy to install and are highly appreciated for their seamless finish and dimensional accuracy. These gears are highly reliable and perform flawlessly. The company has maintained high standards by providing superior quality spur gears. These spurs are designed to exactly meet the set industrial norms and standards. Backed by expert professional, the company provides best customization facility to deliver the exactly desired product in accordance with given specifications. Features: flawlessness; high tensile strength; easy-installation; and rigid construction. Covaai Gears leveraged well qualified and experienced engineers and modern facilities with expertise in gear technology to emerge as one of the leading manufacturers of gearboxes.

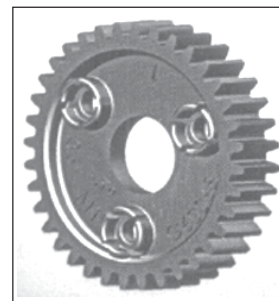

Contact:

Covaai Gears
No: 203-B, 6th Street, Extension KK Pudur
PO Saibaba Colony, Coimbatore, Tamil Nadu 641 038
☎ 0422 – 244 9711 • Fax: 0422 – 244 5644
Mob: 098433 44935 • E-mail: sales@covaaigears.com

Subscription Order Form

To,
 The Circulation Manager
Product News Publication
 104, Sudama Yash, Opp: Central Bank, Kelkar Cross Road,
 Ramnagar, Dombivli (E), Thane 421 201

Dear Sir,

I / We would like to subscribe **Industrial Products Source**.

Please commence my/our subscription with the _____ (Month & Year) Issue.

Name _____

Address _____

_____ Pin code _____

Telephone _____ Mobile No. _____

Date: _____ Signature _____

Industrial Products Source

Visit us at: www.ips.co.in / www.industrialproductssource.com

1-Year (12 issues) ₹ 300/-

2-Year (24 issues) ₹ 550/-

3-Year (36 issues) ₹ 750/-

Subscribers who wish to receive magazine through courier, will be charged extra

I / We enclose the payment of Rs. _____

in favour of **PRODUCT NEWS PUBLICATION**,

by "A/c. Payee" Draft / Cheque No. _____

Dated _____ of Bank _____

Our Bank details for NEFT payment Transfer:

Name of the company: **PRODUCT NEWS PUBLICATION**

Name of our bankers: **IDBI BANK, Dombivli (East Branch)**

Thane Dt.

A/C NO: 118102 00000 6569

Nature of Account: Current

IFS Code: IBKL0000455

Micro Drill EDM, BH-703

J K Machines supplies Micro Drill EDM. Its salient features are: Digital processing parameters with Omron micro switches; High speed quill moment with DC servo motor; Ball screw for X and Y axis; LM guide for Z axis; Parameter changing is allowable during operation; Job material steel/copper/brass/aluminium/carbide/Hard alloy, etc; Adjustable high pressure compact pneumatic water pump with filtration; Used for wire cut pre holes, Air vent holes removal of broken drill and tap; 3-axis DRO with depth control; Motorized work head movement; Electrode dressing facility; Tap water is used as dielectric fluid; Precise granite table with steel covers; Compact footprint. Specifications – Work Table: 400 x 600 mm; Working Travel: 300 x 400 mm; Z axis Travel: 350 mm; Distance from Quill to Table: 300 + 350 mm; Max Machining Current: 30 A; Drilling Range: 0.20 - 3.00 mm; Max Electrode length: 500 mm; Max work piece weight: 300 kg; Max machining speed: 40-60 mm/min; Drive System for Z axis: DC Servo; Max Power Consumption: 3.5 kVA; Input Power Supply: 3 phase, AC415 V/50 Hz; Working Liquid: Distilled water; Machine dimension: 1000 x 1000 x 2100 mm; Machine weight: 900 kg. Standard Accessories: Levelling Pads; Clamping Kit; Tool Kit; Water Tank; Guides; Electrodes; Rubber Seals; Job Mounting Fixture; Machine Lamp; and Lubrication Pump.



Contact:

J K Machines

E-64A, Jeewan Park, Uttam Nagar, New Delhi 110 059

Mob: 98105 03936, 75299 99900

E-mail: jk_machines@hotmail.com

Hydraulic Presses & Machinery

Omkar Enterprises manufactures all types of Hydraulic Press and Machinery. The products range is: Deep Draw Presses, Hydraulic Press (H Type), Hydraulic Hand Press (H Type), Hydraulic Hand Press (C Type), Hydraulic Cutting Press, Power Pack Unit, CNC Power Pack Unit, Paper Dish Press, Rubber Press (photograph), Fix Frame Press, etc.



Contact:

Omkar Enterprises

Plot No: 816/B, Road D, Kishan Gate, GIDC

Metoda, Dist: Rajkot, Gujarat 360 021

Mob: 98256 16020, 98254 66934

E-mail: omkarenterprise11@yahoo.com

EDM Drilling Machine

Berlin Machine Corporation offers EDM Drilling Machine. Features: Drilling diameter from 0.3 mm to 3 mm; the maximum depth ratio could be 300:1; Blind holes can also be drilled, Precision (hole straightness) is less than 0.04 mm; Can drill on oblique and curved surface directly; Fast processing speed and low consumption; Can use water as coolant, low cost and no pollution. Specifications of FDD703.30 – Working Table: 360 x 480; Stroke X-Y: 300 x 400 mm; Electrode diameter: 0.3 mm - 3.0 mm; Spindle Stroke: 200 mm; Servo Stroke: 300 mm; Max adjusting speed of spindle: 200 mm; Turn Head (C axis) Speed (MM/min): 20-120 mm/min; Distance between working table and guider: 300 mm; Power: 1 phase 220/3-phase 415 V/50 Hz/4.0 kW; Maximum Working Current: 30 A; Capacity of Working Fluid: 25 L; Max Pressure of working fluid: 7 MPA; Dimension (L x W x H): 1060 x 750 x 1700 mm; Weight: 600 kg. Standard accessories: 3-axis DRO X, Y and Z axis; Coolant System; Electrode one set; Guide 2 numbers; Seal; and one Drill Chuck.



Contact:

Berlin Machine Corporation

Bhairavnath Industrial Estate, Gat No: 2/1, Plot No: 15

Nr: Choudhary Weighing Bridge, Dehu-Alandi Road

Chikhali, Pune, Maharashtra 411 062

☎ 93726 23735, 95031 31666

E-mail: infoberlinmachine@gmail.com

Magnetic Coolant Filters

Universal Precision Tools manufactures Magnetic Coolant Filters in 3 different Types of drums: Plain, Serrated and Ring Types for effective removal of ferrous contaminations from coolant. The geared motors of heavy duty types and gives trouble free service for number of years. Capacity is from 30 lpm to 3000 lpm. The above magnetic separator is with stainless steel drum, with powerful magnets inside. The rare earth high power magnetic separators are also available as per customer's requirement.



Contact:

Universal Precision Tools

Plot No: 42/3B, M T Sagar, Gokul Road

Hubli, Karnataka 580 030

☎ 0836 - 233 3383, 233 1598 • Fax: 0836 - 233 2472

Mob: 93434 01999 • E-mail: uc@aalpha.net

Dynamic Balancing Machines, Vertical Type

Fasne Test Equipment Pvt Ltd offers Dynamic Balancing Machines, Vertical Type (Model FVBM-D). This Vertical type hard bearing machine is for single plane balancing of rotors like clutch plates, fan blades, fly wheels, magnetos, grinding wheels, impellers, pulleys, etc.; Processor based or DSP based measuring panel with auto compensation facility; Minimum achievable unbalance up to 0.5 micron shift in c.g.; Various models suitable for rotors from 0.3 kg to 300 kg; Computerized/Electronic versions with printer facility and as per customers' requirements, can also be supplied; Machines conform to IS: 13277-1992/ISO: 2953. Features of DSP Panel: Compact design, No external hardware; Higher accuracy, increased reliability; Auto calibration; RS 232 Serial Interface (Computer connectivity); Adjustable auto cycle; Auto ranging from 0.1 g and up to kilograms; Auto tolerance indicator in g and in gm.mm; Actual RPM Indicator (Resolution +/-1 RPM); Very less power consumption (less than 50 mA).

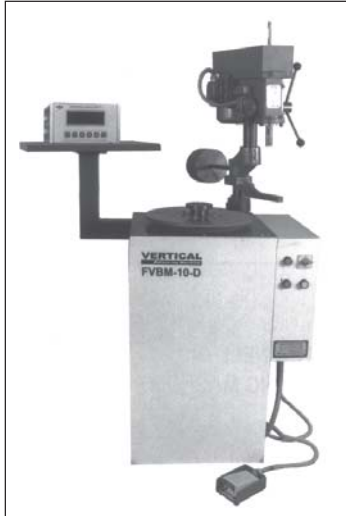

Contact:

Fasne Test Equipment Pvt Ltd
C-45/2, MIDC Area, Miraj, Dist: Sangli, Maharashtra 416 410
☎ 0233 – 264 4332, 264 4532
E-mail: enquiry@finegrouptest.com

Polymer Sprockets & Gears

UltraPlast Chainbelts Private Limited offers a wide range of ready to use Moulded as well as Machined Sprockets for Slat Chains or Roller Chains in different designs, sizes and materials suitable for diverse chain types and applications. The Company's products range includes: Plastic Modular Belting, Plastic and Stainless Steel Slat Chains, Guide Rails and Wear Strips, Conveyor Accessories, Machined Components for industrial applications, etc.

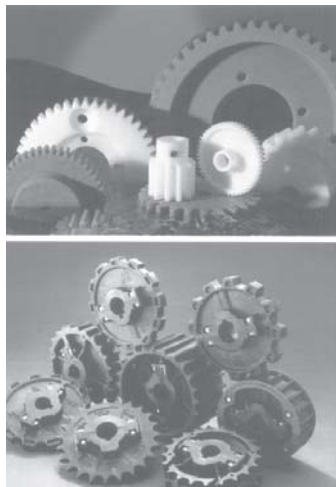

Contact:

UltraPlast Chainbelts Private Limited
81 New DLF Industrial Area, Faridabad, Haryana 121 003
☎ 0129 – 411 3186 • E-mail: info@ultraplast.in

Electric Tube Cleaner

Subzero Tube Tools Pvt Ltd offers Electric Tube Cleaner. Features: It operates on single phase supply, which is easily available. Water flows through the shaft. It softs the scale and flushes out from the tube. Tube cleaner is operated by foot. So operator concentrates on cleaning operation. Flexible shafts are easily connected and disconnected mobile trolley for easy movement. Water flows through the shaft when operator presses the foot pedal. Subzero provides quality tools and service to the Heat Exchanger, Boiler Manufacturing and Re-Tubing industries. Their products are exported to oil refining, chemical and petro-chemical production, power generation, desalination, sugar refining, ship maintenance and many more. The Company carries extensive stocks of their standard products to ensure to meet their customer's immediate needs in the quickest turnaround time and deliveries.



Contact:

Subzero Tube Tools Pvt Ltd
Plot D-8, Indian Industrial Distributor Premises
Road No: 32, Bhavani Nagar, Wagle Industrial Estate
Thane 400 604
Mob: 93241 50671 • E-mail: sales@tubetools.co.in

Precision Moulds

VM Enterprises designs and manufactures of precision moulds. The Company supplies high quality moulds and services, delivered on time at competitive prices. It can design and manufacture various types of moulds required in industries like Automotive, Electrical, Consumer Electronics, Irrigation, Piping distribution, Packaging, Home Appliances, etc. up to the size of 800 ton machine capacity. The products range is: Auto Parts – Wheel Cover Mould, Badges; Farm Equipment; Electrical Parts, etc.

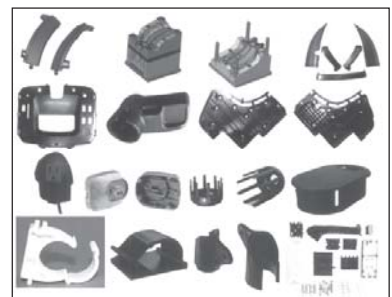
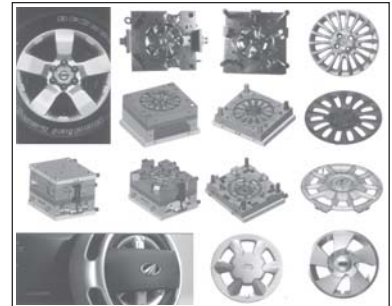

Contact:

VM Enterprises
D-37/2, MIDC, Ambad, Nashik, Maharashtra 422 010
Telefax: 0253 – 238 4001 • E-mail: vment.idagal@gmail.com

Buttweld Fittings

Rajendra Industrial offers Buttweld Fittings such as 90° Elbow, 45° Elbow, U bend, Piggable bend, Reducers, Caps, Cross Tee, Stub ends, Pressed Stub ends, Welding Collars, 45° Laterals, and Barrel Nipple types. The Company's other products range includes: Flanges, Dairy/TC Fittings, Pipes, High Pressure Fittings, and Outlet Fittings.



Contact:

Rajendra Industrial Corporation
99/99-A, Shiv Vilas Building, 2nd Pathan Street
Gr Floor, 5th Kumbharwada Lane, Mumbai 400 004
☎ 022 – 2385 7169, 6636 2120
E-mail: sales@rajendrafittings.com

Heavy Duty Bag Closing Machine

Gabbar Engineering Co manufactures Heavy Duty Bag Closing Machine. Special Features: Sturdy, Rigid, easy to operate and efficient bag closing machine for closing mouths of filled bags, in industries like Fertilizers, Sugar, Rice/Flour, Cattle/Poultry Feed, Powder Milk etc. Moving parts in main housing totally sealed against dirt, dust, and foreign particles. The stitch width is adjustable from 5 mm to 9 mm. Provision of a variable speed pulley allows easy synchronization with an existing conveyor. Ease of inspection and maintenance is ensured by a simple mechanism. Capable of stitching filled bags of all kinds like HDPE, PP, Jute, Polyjute, Hessian and craft paper bags with synthetics or cotton thread. Special designed pedestal column for Dual Head System. Specifications of Model AS 800 VM – No of needle: Single; Seam: Double thread chain stitch; Speed: 1000-1200 bags/hr; Stitch width: 5-0 mm; Needle: DRX2-26 (Oxygen/Groz-Beckert); Thread: Cotton or synthetics; Cutter Type: Mechanical Thread Cutter; Lubrication System: Manual Oil Feed and Oiler System; Drive Motor: for Sewing head 0.5 HP, 3-phase for conveyor 1 HP, 3-phase; Conveyor: Slat or Belt type; Conveyor dimension: 2000 mm x 390 mm x 275 mm; Height adjustable: 445-725 mm; and Net weight: 325 kg.

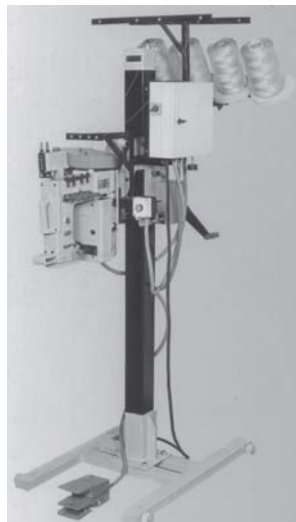

Contact:

Gabbar Engineering Co
Plot No: 1903, Phase III, F-Road, GIDC
Opp: Kalupur Comm Bank, Vatwa
Ahmedabad, Gujarat 382 445
☎ 079 – 2583 0971 • Mob: 98240 62000
E-mail: umesh@gabbar.com

Rotary Surface Grinder with Vertical Spindle

Alex Machine Tools offers Rotary Surface Grinder with Vertical Spindle Model R40. Its Technical Specifications – Magnet Table diameter: 1000 mm; Segmental Wheel: 560 mm; Segments per set: 10; Maximum wheel clearance: 250 mm; Quick Speed: 750 rpm; Table Speed: 6 and 12 rpm; Automatic Feeds per min (infinitely variable): 0.05-1.0 mm; Spindle Motor: 30 HP; Table Moor: $\frac{3}{4}$ HP; Machine size: 2300 x 1700 x 1900 mm; Length x Width x Height: 90 x 67 x 75 inch; Net Weight of machine: 6500 kg; Gross weight of machine: 7500 kg. Standard equipment: Electromagnet chuck; Segmental chuck with 1 set of grinding segments; Hydraulic built-in wheel dressing unit; Demagnetizer – in built (Electronic type); Coolant system with magnetic separator – 100 LPM; Variable magnetic power for grinding thin jobs; Auto central lubrication for slides; FANUC CONTROL system for vertical infeed and with precision ball screw ensuring: Smooth, easy, free from stick slip infeed; Zero Backlash; Long life; Table Guard; Set of wrenches; all electric motors, internal wiring and control gear.



Contact:

Alex Machine Tools
8 Gaiwadi Industrial Estate, S V Road
Goregaon (W), Mumbai 400 062
☎ 022 – 2874 3226, 2874 3744
E-mail: amt@vsnl.com

CNC External Cylindrical Grinding Machine

Sharda Mechanic Works manufactures CNC External Cylindrical Grinding Machine (Straight/Angular) ECG Series. Its Specifications: Capacity – Swing over Table: 300/350 mm; Max grinding length: 500/800/1000/1250 mm; Control System: FANUC/Siemens; Rapid Feed Rate X and Z Axis: 7 m/min; Resolution of X and Z Axis: 0.001 mm; Work Head – Spindle Nose Taper: 5 MT; Spindle Speed (variable): 50-500 rpm; Grinding wheel head (Straight wheel) – Grinding wheel dia: 400/500/600 mm; Grinding wheel width: 50/80/120 mm; Surface speed: 33/45 m/s; Motor Power: 3.7/5.5 kW; Grinding Wheel Head (Angular Wheel) – Grinding wheel dia: 500/600 mm; Grinding wheel width: 50/80/120 mm; Grinding Wheel Configuration: 30°; Surface speed: 33/45 m/s; Motor Power: 3.7/5.5 kW; Tail Stock: $\frac{3}{4}$ MT.

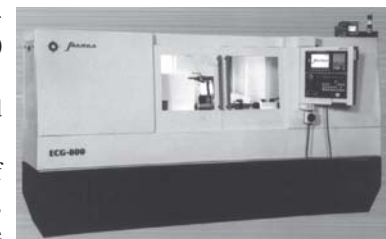

Contact:

Sharda Mechanic Works Pvt Ltd
Dudharej Road, Surendranagar, Gujarat 363 001
☎ 02752 – 254 775 • Mob: 98257 77003, 96383 33338
E-mail: sharda@shardamachines.com

Crimping Press

Sai Paradise offers HF-10000 Crimping Press that has been specifically designed to crimp very big-section wires. It also handles battery cables processes up to the pressure of 10 tons and above. Its design capabilities are unique and built for optimal ease of use and changeover. This HF-10000 is a versatile powerful crimping press and comes with the robust mounting table assembly in the plug-and-use manner. This HF-10000 is also integrated with unique features like LED lighting source built into the work area, which focuses precisely on the crimp tooling for maximum visibility.

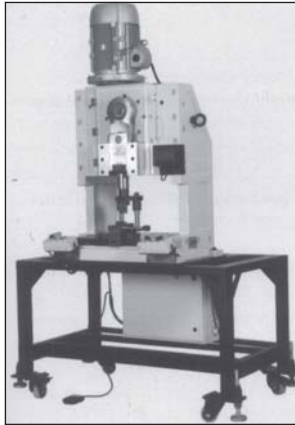

Its terminal eel bracket allows for quick change from side to end feed terminal reels. This Crimping Press also comes with a standard pneumatic feed kit for operation of air-feed applicator. The efficient electronic control operates on 220 V single phase power; and it features both a forward and reverse jog mode for set-up and resetting of the crimping unit. Technical Specifications – Wire size range: Standard – up to 000 AWG (95 mm²); Material thickness: Up to 2.5 mm and crimp length zone up to 20 mm; Crimping Force: Standard – 100 kN (22040 lbs); Power Supply: 230 to 240 V (50/60 Hz) (Optional 110 V); Input Voltage: 440 V, 6 A, 50/60 Hz, 3-phase; Stroke: 40 mm fixed (1.57 inches) or 50 mm fixed (1.96 inches); Shut height: 158 mm (6.220 inches) or 190 mm (7.480 inches); Weight: 450 kg (992 lbs); Dimensions (W x H x D): 1000 x 1900 x 900 mm (39.37 x 74.80 x 35.43 inches) excludes reel brackets; Noise level: < 40 dB A, idle, < 70 dB A crimping; Press Activation: Foot pedal; Cycle Time: < 2 sec; Height adjustment: ±0.25 mm (0.009 inch) in increment (approx.).

Contact:

Sai Paradise Machine Tools

No: 7-650/1, Subash Nagar, IDA, Jeedimetla
Hyderabad, Telangana 500 055

☎ 040 – 2309 6593 • E-mail: info@saiparadise.com

Pre Filters

Freudenberg Filtration Technologies (India) Pvt Ltd supplies a range of Filters like Pre Filters, Riser Filters Pleated Type; Fine Filters Pleated Type, Pocket Type, Aluminium Separator Type; HEPA Filters Aluminium separator Type – Normal Flow, and Super Flow Types; Combination Filters, etc. The Pre Filters Pocket Type finds applications in primary or secondary air intake in air handler and ventilation units for comfort and clean room as well as in paint booth.

Contact:

Freudenberg Filtration Technologies (India) Pvt Ltd
402 B&C, 4th Floor, Town Square, New Airport Road
Viman Nagar, Pune, Maharashtra 411 014

☎ 020 – 6763 3600

E-mail: cs.cleanroom@freudenberg-filter.com

Tee & Elbow Beveling Machine

Abexmatic Hydraulics Pvt Ltd manufactures Tee and Elbow Beveling Machine, which has the features of unique design, compact structure, vivid look as well as convenient to operate. This machine is ideal equipment for chamfering metal right angle elbow end. The product is processed by the machine complies with the relevant elbow beveling standard. The machine drives strongly, cuts quickly and works efficiently. The machine consists of novel-structured floating cutter support, well and truly oriented work piece clamp and qualified excellent hydraulic feed lock device to ensure normal or quick forward/backward movement of the work piece on the slipway. There are three cutters for each clamp disk, they serve for different range of work and can work at the same time to ensure the effective cutting and fully satisfied the stable requirements of the guide track under the status of strong cutting. While the hydraulic control system its cutting speed can be adjusted randomly by the size and the thickness of the calibre.

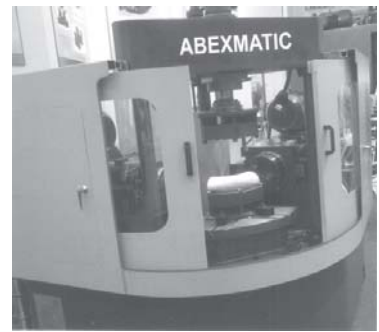

Contact:

Abexmatic Hydraulics Pvt Ltd
H131, Sector-4, DSIIIDC Industrial Area
Bawana, Delhi 110 039

☎ 011 – 2776 1231 • Mob: 98101 30494

E-mail: abexmatic@yahoo.co.in

Water Storage Tanks

The Supreme Industries supplies Water Storage Tanks SILT-ANK in Overhead Water and Loft Tank types. Features: Made from 100% virgin raw material; Tough and durable; Easy installation; UV stabilized; Excellent chemical resistance; Full capacity guaranteed; Rotationally moulded for maximum strength and performance; Rigorously tested to ensure the quality; meets and exceeds all quality parameters as specified in BIS; Strong and compact cover with locking provision for easy opening and closing; Four layered tanks are thermally insulated using foam layer.



Contact:

The Supreme Industries Ltd
1161/1162 Solitair Corporate Park, Building No: 11
167 Guru Hargovindji Marg, Chakala, Andheri-Ghatkopar
Link Road, Andheri (East), Mumbai 400 093

☎ 022 – 6771 0000, 4043 0000

E-mail: pvc-pipes@supreme.co.in

Mould Base, Precision Components

Vishal Precision Products Private Limited, an ISO 9001:2008 Certified Company is specialized in mould base, pre-

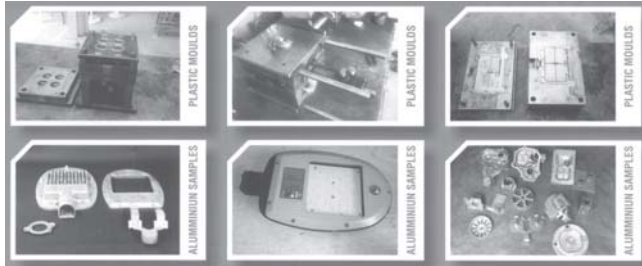

cision components and sub-assemblies/assemblies for Printing, Plastic, Textile, Aero and Oil Type machinery having customers domestic and worldwide. The Company



specialize in: Custom-built Mould Bases; Specialized Mould Bases; Die Casting Mould Bases; Specialized Machining; Assembly Modules for Export; and Precision



Machined Components. The Company has the capacity to produce standard housing from 125 x 125 mm to 1000 x 1500 mm for plastic moulds, Die housing for pressure die casting dies, Plate die sets for press tools, using various materials such as C45, P20, P20-HH or any other, as per customer requirement.

Contact:

Vishal Precision Products Private Limited
Glory Manor, 113-A Kaveri Nagar, V K Road
Peelamedu, Coimbatore, Tamil Nadu 641 004
☎ 0422 – 251 3064 • E-mail: mfg@vishalprecision.com

Cooling Tower Water Treatment Systems

Sevcon India Private Limited offers Cooling Tower Water Treatment Systems. It is a Replacement for Chemical Dosing Plants. No Chemicals used; Removes Scale, Corrosion, Bio-fouling, Reduces requirement of make-up water.

Contact:

Sevcon India Private Limited
1013 Chiranjiv Tower, 43 Nehru Place, New Delhi 110 019
☎ 011 – 4762 9300 • E-mail: enquiry@sevcon.in

Plastic Moulds & Dies

Shaji Moulds And Products, an ISO 9001-2008 Company has been manufacturing moulds and dies, moulded components supply, sheet metal components, patter making, precision machined parts supply. The Company maintains high level finish and accuracy to meet customer satisfaction. The Company is committed to achieve customer satisfaction by design

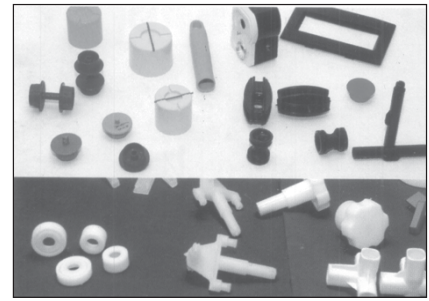

and manufacturing of moulds, dies and tools with world class quality and delivering on time with cost effective solutions. The products include: Aluminium PDC Samples, Bakelite Dies Samples, Precision Machined Components, 1 to 18 Modular Switch Boxes, Plastic Samples, Pressed Parts, Soft PVC Samples, Rubber Parts, etc.

Contact:

Shaji Moulds And Products
275/D1 Kurumban Thottam, 11th Street
Ganapathy Pudur, Coimbatore, Tamil Nadu 641 006
☎ 0422 – 243 1786 • Mob: 98941 79016
E-mail: rafisajimail.com

Hydraulic Press, 4-Column Type

Abexmatic Hydraulics offers 4-Column Type Hydraulic Press. Its features are: the deep drawing hydraulics press is specially designed for best performance, equipped with PLC and LVDT depth control while being, highly rigid, compact and space saving in design; this machine is widely used in manufacturing SS sinks, LPG cylinders, geysers, air conditioners, cooking hobs and other automobile and industrial sheet metal components; specially designed for deep-drawing and punching, this press can handle tough processing that cannot be done mechanically; the high-precision design makes it safe and dependable; and the forced lubrication system keeps sliding surfaces in the excellent condition and parts move smoothly in maintenance. The company is an ISO 9001/2008 certified, with its forte in manufacturing hydraulic presses and machines.

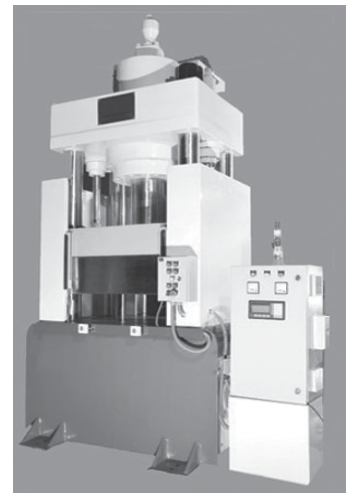

Contact:

Abexmatic Hydraulics Pvt Ltd
H-131, Bawana Indl Area., Sector 4, Bawana, Delhi 110 039
☎ 011 – 2776 1213 • Mob: 98101 30494
E-mail: abexmatic@yahoo.co.in

Guided Wave Radar Level Transmitters (Rod/Cable Type)

Nagman Instruments & Electronics (P) Ltd manufactures Guided Wave Radar Level Transmitters (Rod/Cable Type). Specifications – Measuring range: 6 m to 20 m; Accuracy: ± 5 mm or ± 10 mm; Frequency: 500 MHz – 1.8 GHz; Antenna Types: PTFE sealed cable, single/double cable and coaxial tube; Process temperature: -40 to 400°C ; Process pressure: -1 to 40 bar; Signal output: 4 to 20 mA/Hart; Explosion proof Grade: ExiaIICT6Ga/Exd ia IIC T6Gb. Applications: Liquids (including corrosive liquids/low dielectric constant) and solid powder. The company also offers Radar Level Transmitters (Cone Type); Ultrasonic Level Transmitters; Level Calibration System/Test Rig; etc.



Contact:

Nagman Instruments & Electronics (P) Ltd
Nagman Complex, Chennai-Bangalore NH-4
Nazarathpet PO, Chembarambakkam, Chennai 600 123
☎ 044 – 6677 7000, 6677 7011
E-mail: support@nagman.com

Rotary Triple Twin Gear Pump

Del Pd Pumps offers Rotary triple twin gear pump Type NDX. It has a pair of impeller gears, timing gears and reduction gears. Features: Compact, economical and low noise. Sizes from 5" to 12" NB (Flanged to ASA 150 Class); Capacity from $80 \text{ m}^3/\text{hr}$ to $550 \text{ m}^3/\text{hr}$, Pressure up to 11 kg/cm^2 ; Viscosity up to 1,00,000 cst; Temperature up to 110°C . NDX Series pumps are designed to handle bulk volume of viscous and semi viscous liquids quite efficiently at medium pressure up to 11 bar. The pump can be coupled directly with drive as impeller speed reduction is made possible within pump, making it very compact and cost economical and thereby reducing the overall cost and space; the timing gear reduces the noise level and enhances the working life of the pump. This pump out performance twin screw pump in all aspect in this range and they are suitable for wagon decanting, cargo un-loading of various viscous liquids such as edible oils, fuel oils, viscose chemicals, etc. Step-down versions are also available.



Contact:

Del Pd Pumps & Gears (P) Ltd
113 GIDC Estate, Wadhwan, Surendranagar, Gujarat 363 035
☎ 02752 – 243 047, 243 678 • Fax: 02752 – 243 744
E-mail: rotodel_adl@sancharnet.in

Attention Readers...

*If you are a manufacturer or dealer of any industrial product,
we invite you to
send your Product write-ups for Free publication,
in about 200 words describing the product, such as
its technical specifications, special features, applications, etc,
along with a clear photograph of the product to:
ipseditor@gmail.com or*

The Editor

Industrial Products Source

Product News Publication

104, Sudama Yash, Opp. Central Bank, Kelkar Cross Road,
Ram Nagar, Dombivili (E), Thane 421 201

Blow Moulding Machines

Blow Engineering is a distinguished manufacturer, exporter and supplier of a wide assortment of Plastic Extrusion Blow Molding Machines. The blow moulding machines are suitable to make Containers in blow HDPE, LDPE, PVC, PET-G and PP materials. Product range: 5 ml to 100 litres. Salient Features: Fully automatic machines with options of PLC. Microprocessor Control or HMI (touch screen panel); Continuous Extrusion Heads; Greater Reliable and versatile machines with top quality production; AC drive variable speed for power saving/Parison control; Compact design, and easy to operate.



Contact:

Blow Engineering

1/2 Milan Sadan, Khairani Road
Saki Naka, Andheri (E), Mumbai 400 072
☎ 022 – 2852 0554 • Mob: 98191 25394
E-mail: sales@blowengg.com

Pet Strength Blow Moulding Machine, Polo Series

Blowtech Machines offers Polo Series Pet Strength Blow Moulding Machine. Features: The machine adopts human-computer interface to control the whole working procedures, auto-loading, auto blowing, auto dropping, fast speed, accurate position, smooth action; According to special demand, adopt cross double crank pressed clamping, with strong clamping force, mould open stroke can be adjustable according to the bottle size to save the time; For infrared heater lamps



have strong penetrations, performs are heated uniformly while rotating, PLC or electronic pressure adjustor controls each group of temperature separately; Particular pre-heater design makes perform close while heating, change space, shorten heating tunnel and reduce energy consumption according to the bottle size while blowing; the air supply system consists of sight blow, high pressure blow, low pressure action, to supply enough air for different products; Reliable and Special valve design make all the air system clear; Shifting servo motor is more accurate and faster; Connecting rod automatic lubrication oil device protects the machine well; Production workmanship process is fully automatic to make bet quality and pollution-free. It holds less investment, high efficiency, easy operation, simple repair, safety etc. Technical Specifications: Forming – Cavity Pitch: 110 mm; Mould dimension (L x H/thickness: 330 x 330 mm max/160 Fix; Clamping stroke: 200 mm max; No of cavity: 3 pcs; Product: Product height: 360 mm max; Container volume: 1000 ml max; Neck outer diameter: 28 mm (max); Product outer diameter: 90 mm; Theoretical production: 1800 pcs/hr; Power – Total consumption power: 15 kW; Total consumption with utility: HP connected load; Heating Power: 14 kW; Gear Motor Conveyor motor + blower: 1 kW; Air – Operation Pressure: 8 kg/cm²; Air Consumption for System: 28 cmf; Blowing Pressure: 26 kg/cm.

Contact:

Blowtech Machines

G-21 Shailesh Indl Complex, Opp: Hyundai Showroom
Valiv Phata, Sativali Road, Vasai (East)
Dist: Palghar, Maharashtra 401 208
Mob: 98331 11976, 98335 55976
E-mail: blowtekmachines@gmail.com

Statement about the ownership and other particulars about **Industrial Products Source** as required to be published in the first issue of every year after the last day of February, under Rule 8 of the Registrar of the Newspapers, Ministry of Information and Broadcasting.

Form IV

1. Place of Publication : Dombivli
2. Periodicity : Monthly
3. Printer's Name : Mohanan. N.
Nationality : Indian
Address : A/10 Jayashree Laxmi Puja, Plot 78/82
Ramachandra Nagar, Dombivli (E), Thane 421201
4. Publisher's Name : Mohanan. N.
Nationality : Indian
Address : A/10 Jayashree Laxmi Puja, Plot 78/82
Ramachandra Nagar, Dombivli (E), Thane 421201
5. Editor's Name : Mohanan. N.
Nationality : Indian
Address : A/10 Jayashree Laxmi Puja, Plot 78/82
Ramachandra Nagar, Dombivli (E), Thane 421201
6. Name and address of the individuals who own the magazine and partners or shareholders owning more than 1 per cent of the total capital : Owned by Product News Publication
7. Partners
 - i) Mohanan. N. : A/10 Jayashree Laxmi Puja, Plot 78/82
Ramachandra Nagar, Dombivli (E), Thane 421201
 - ii) Jayashree Mohanan : A/10 Jayashree Laxmi Puja, Plot 78/82
Ramachandra Nagar, Dombivli (E), Thane 421201
 - iii) Madanmohan Nair : B-201, Smit CHS, P&T Colony
Dombivli (E), Thane 421 201
 - iv) Panchalykutti MNair : B-201, Smit CHS, P&T Colony
Dombivli (E), Thane 421 201

I, Mohanan N, hereby declare that the particulars given above are true to the best of my knowledge and belief.

Dated: 1st March 2021

Mohanan. N.
Signature of the Publisher

Subscribe to
Industrial Products Source
at ₹750/- for 3 years

Plastic Injection Moulding Machine

Tex Shine Plastic Hydraulic manufactures Plastic Injection Moulding Machine Plunger and Screw Types. Applications: Textile and Automobile Components; Components

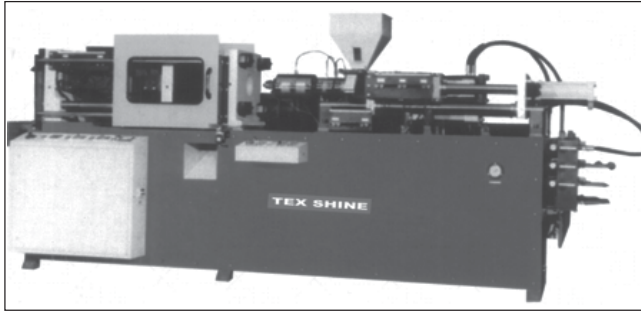

for mixer, wet grinders, washing machines, pumps and other domestic products; Toys, stationary, kitchenware, furniture items, flower pots; Cosmetic, Toiletries and Pharmaceuticals (taps, caps, lids, etc); Electrical and Electronic Plastic Components (Engineering Plastics); Bathroom fittings and many others; Jewel box, Sweet box, dates box, etc.

Contact:

Tex Shine Plastic Hydraulic
125 Kannemar Nagar, Sathy Road, Ganapathy
Coimbatore, Tamil Nadu 641 006
☎ 0422 – 253 9055 • Mob: 94430 59638
E-mail: vinplastatech@gmail.com

Precision Injection Moulded Plastic Components

Vishakha Plastics is a key manufacturer and supplier of innovative plastic products for many companies in the industrial sector ranging from Textile, Automobile, Pharma-

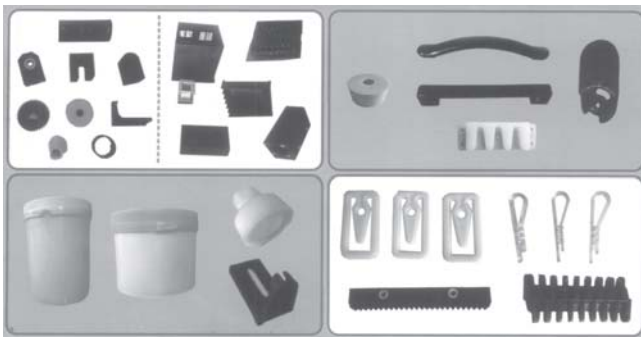

ceutical, Industrial, Electrical and Electronics. The company's capabilities consists of product design and development injection moulding, assembly, machining and testing; and specializes in precision moulding of engineering thermoplastic like nylon, ABS, Delrin, Polycarbonate and other materials used in plastic engineering.

Contact:

Vishakha Plastics
48-49 Shrinathjee Industrial Estate
Nr: GIDC Water Tank, Phase-I, Vatva
Ahmedabad, Gujarat 382 445
☎ 079 – 2543 1103 • Mob: 94263 60685
E-mail: vishakhaplastics@gmail.com

Air Sterilizer

Haris Sensor Technologies' air sterilizer is suitable for homes, malls, call centers, offices, hospitals, operation theatres, cinema halls, banks, ATM centers, A/C buses and A/C rail coaches, etc. Features: Ion (-) – more than 8 million ions are generated per second creating a fresh environment. Ozone (optional) – it generates around 50 mg ozone per hour removing the organic odour effectively, and increases the quality of oxygen in the air. Activated carbon – catalyze and neutralizes the harmful gases like formaldehyde, H₂S, NH₃ efficiently. The absorption area of the activated carbon in the unit is up to 30 square metres. Photo catalyst – restricts growth of the virus effectively. UV light – the sterilization rate is more than 97.6%. HEPA filters – absorbs particulate down to 0.0001 mm like pollen, dust and germs with purification efficiency of up to 99.999%. Aroma (optional) – there is a solid aroma box to emit fresh and natural floral perfume.



Contact:

Haris Sensor Technologies Pvt Ltd
223 Shanti Industrial Estate, Sarojini Naidu Road
Mulund (W), Mumbai 400 080
Telefax: 022 – 2567 2147, 2567 2204
E-mail: info@haris.in

Automatic Cutting Machine for Corrugated Tubes

Machine Maker R S is offering Automatic Cutting Machine for Corrugated Tubes. Features: it is useful for pre-slit as well as un-slit PVC corrugated tubes; the machine uses a specially developed uni-que cutting mechanism and belt feeding system; both these ensure that the hollow tubes do not collapse during feeding or cutting; this machine is tabletop, user-friendly, and automatic; it comes with in-built production counter, which indicates the number of cuts taken; and voltage servo-stabiliser (2 kVA) or CVT (1 kVA) is must; proper earthing is essential and it comes with automatic cutting machine. The company is a manufacturer of industrial cutting tools, high speed cutting machines, automatic cutting machines and sleeve cutting machines.



Contact:

Machine Maker R S
5/6 Chandrashekar Soc, Swami Nityanand Marg
Andheri (E), Mumbai 400 069
☎ 022 – 2585 0713 • Mob: 98212 68704
E-mail: response@machine-maker.com

Cylindrical/Taper & Grooved Pins

R K Engineering Co manufactures and supplies cylindrical, taper and grooved pins. Cylindrical (dowel) pins are used to retain parts in a fixed position or preserve their alignment. These cylindrical hardened pins are manufactured to IS: 6689 and unhardened to IS: 2393, while taper pins manufactured to IS: 6688 are preferred for parts that have to be taken apart frequently in which case, cylindrical pins would tend to wear the holes. Grooved pins have three parallel equi-distance longitudinal grooves impressed on their exterior surface. These grooved pins are manufactured to IS: 7368 (DIN-1471), IS: 7385 (DIN-1472), IS: 7383-86 (DIN-1475), DIN-1473 and DIN-1474. Also manufactured are non-standard pins as per customer's requirements.



Contact:

R K Engineering Co
12 Nanik Motwane Marg, Opp: HDFC Bank
Fort, Mumbai 400 023
☎ 022 – 2267 1141
E-mail: rkengcomp@gmail.com

Auto Tune PID Controllers EC Series

Nippon India offers EC Series controllers that are micro-processor based controllers, and have been designed with high accuracy input, various output option with good reliability and repeatability. EC Series used PID Algorithm to implement excellent control for wide range of applications like Temperature, Humidity, Pressure, Flow and PH as well other Process controls. EC series AT Auto tuning function can calculate the optimized PID value for your control system to avoid manual setting in different process conditions. Features – Universal input sensor (J, K, R, S, T, B, E, Pt-100, 0~20 mA, 4~20 mA, 0-10 V DC); Main control O/P: Relay, SSR, 4~20 mA DC; Alarm: Relay 93 A); Display: 4-digit PV/4 digit SV); Visual LED indication: Control O/P, alarm, auto tune.



Contact:

Nippon India
237/8 New Sonal Link Indl Estate, Bldg No: 2
Link Road, Malad (W), Mumbai 400 064
☎ 022 – 4062 0000 • Fax: 022 – 4062 0099
E-mail: sales@nipponindia.com

Fastener Handling Slat Conveyors

Anyway Engineering manufactures fastener handling slat conveyor (Hinge Type with side chain). It is a specially



designed and state-of-art manufactured conveyor is highly used in Fastener, and Automobile industries. This conveyor is also used as Chip conveyor. The company's time proven design in field of Slat Conveyors has achieved them of better designs, efficiency and quality. Features include: High quality slats; rigid construction; Low maintenance; efficient design.

Contact:

Anyway Engineering
Factory No: 3, Sonarpada (Mhatre Pada), Near Tempo Naka
Behind W-230, Phase-II, Dombivli (E), Maharashtra 421 204
Mob: 98214 65799 • E-mail: anywayengg@gmail.com

Energy Efficient Air-Compressor

Elgi Equipments offers a wide range of Energy Efficient Air-Compressor. Features are: Elgi's portable compressors, renowned for their reliability and ruggedness, are available in single and two-stage models; these compressors find wide range of applications across the cable laying, blast hole drilling, exploratory drilling, construction, coal and marble mining, sandblasting, stone mining and crawler drilling; Elgi has a legacy of providing reliable compressed air solutions to the mining industry for over four decades; its have to work in dusty areas and high ambient temperatures, every compressor has been fitted with pre-cleaners and a filtration system that prevents dust from entering the compressor and the engines; and with a robust industrial grade steel enclosure and powder coated canopy, our compressors offer maximum corrosion resistance and durability. The company is a leading air compressor manufacturer with a board line of innovative and technologically superior compressed air systems.



Contact:

Elgi Equipments Limited
Trichy Road, Thiyagi Shanmuga Nagar, Vasanth Nagar
Singanallur, Coimbatore, Tamil Nadu 641 005
☎ 0422 – 258 9555 • E-mail: enquiry@elgi.com

Crimping Press

Sai Paradise offers the HF-8000, which is a versatile and powerful bench top crimping press. This dynamic bench top crimping press is uniquely designed for optimal ease of use and change over.

The HF-8000 unit features an integrated LED lighting source built into the work area and focused on the crimp tooling for optimal visibility. The terminal reel bracket allows for quick change from side to and feed terminal reels. This crimping press also includes a standard pneumatic feed kit for operation of air-feed applicator. The robust electronic control operates on 220 V single phase power. It also features both a forward and reverse jog mode for set-up and resetting

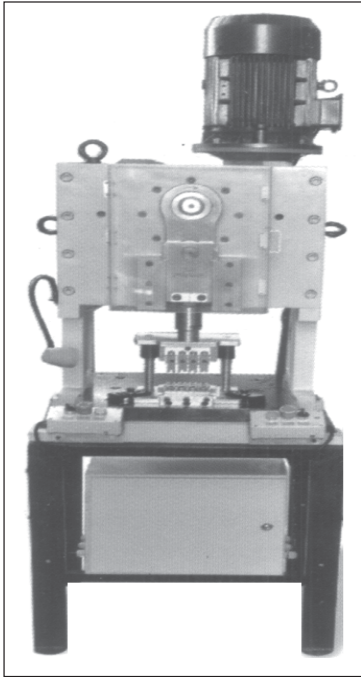

of the crimping applications. The optional crimp force monitor provides for quality monitoring of each crimp. Advantages: High quality Precision Bench Top Crimping; Forward and Reverse Jog Mode; Built in Light Focused on Crimping Tooling; Integrated Pneumatic Feed System; Optional Crimp Force Monitor available; Quick-change applicator base plate; Terminal guides for changing between side and rear feed terminals; Counters for lot size, batch size and total machine cycles; Variable press cycle speed for difficult applications; Jogging function (left/right) with home position display; Automatic home position function; Fine adjustment of crimping height (micro-adjustment); Strong steel, machined base and frame; Pneumatic valve attachment to feed the air feed applicator. Technical Specifications – Wire size range: Standard – up to 2 AWG (35 mm²); Material Thickness: up to 1.5 mm (0.05 inch) and crimp length zone up to 12 mm (0.47 inch); Crimping Force: Standard - 80 kN (17630 lbs); Power Supply: 230 to 240 V (50/60 Hz) (optional 110 V); Input voltage: 200-240 V, 6 S, 50/60 Hz, 1 phase (110 V optional); Stroke: 40 mm fixed (1.57 inch) or 30 mm fixed (1.18 inch); Shut height: 135.78 mm (5.346 inch) or 158 mm (6.220 inch); Weight: 205 kg (452 lbs); Dimensions (W x H x D): 480 x 1100 x 510 mm (18.89 x 43.30 x 20.17 inches) excludes reel brackets; Noise level: <40 dBA, idle < 70 dBA crimping; Press activation: Foot pedal; Cycle time: 1 sec; Height adjustment: ±0.25 mm (0.009 inch) in increment (approx.).

Contact:

Sai Paradise Machine Tools

No: 7-650/1, Subash Nagar, IDA, Jeedimetla

Hyderabad, Telangana 500 055

☎ 040 – 2309 6593 • E-mail: info@saiparadise.com

Gear Motors & Gearboxes

Sudarshan Gears manufactures a range of gear motors and gear boxes such as Horizontal Foot mounted Helical Gear motors, Flange mounted Helical Gear Motors, Brake Motors, Worm Gear boxes, Extruder Gear boxes, Gear motors AC or DC, Special motor Helical reduction gear box, Automobile gears, Industrial Gear Drives, Electromagnetic brakes, DC solenoid Power brakes, Special type electric motors, 2 speed, 3 speed, High torque motors, flange motors, etc. Range for gear motor: 0.10 HP to 50 HP; Output RPM from 1 to 500. Mounting for gear motor: Horizontal base mounting, Vertical base mounting, Vertical up/down flange mounting, Horizontal flange mounting, hollow shaft. Uses: EOT cranes, Textile, chemical, pharmaceutical, and fertilizer, oil, gas, and cement, material handling, and packaging industries.

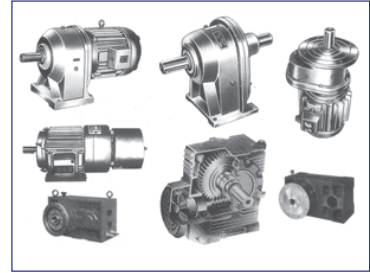

Contact:

Sudarshan Gears

Plot No: 17, Mira Co-operative Industrial Estate

B/h: State Bank of India, National Highway No: 8

Mira, Dist: Thane 401 104

☎ 022 – 2845 5990 • Fax: 022 – 2845 5982

E-mail: enquiry@sudarshangears.com

Tube Notching Machine

Yeshwant Industries offers Tube Notching machine that is applicable to Automotive, and Furnishing industries, home appliances, gymnasium, HVAC pipes, etc. for tube and preparation. Tube Notching machine is an alternative process replacing existing process of manufacturing by press route, milling, mitering, laser cut, etc. Technical Specifications: Hydraulically operated; PLC controlled; Angle variation flexibility up to 30-1200; and 5-10 HP Power requirements. Salient Features: Consistent quality and productivity; Profile consistency; Low tool maintenance; Economic operating cost; Punch re-sharpening alert through SMS; Suitable for faster prototyping; Forming and notching operation can be performed in single stroke. Application areas: All types of applications where pipe end preparation is required.

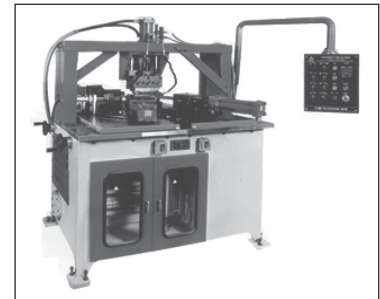

Contact:

Yeshwant Industries

W-38 MIDC, Waluj, Aurangabad

Maharashtra 431 136

☎ 0240 – 255 6280 • Mob: 96899 49022

E-mail: avinash@yeshwantind.com

Thyristor Switch Card for Capacitor Bank

Libratherm offers Thyristor Switch Card, Model TSC-309. Features: the model is specially designed for APFC applications to switch on and off, 3 phase capacitor banks, based on the command from the APFC relay module; it replaces contactor switching with the solid state switching in APFC panels; suitable for fire 2 sets of 25 A to 500 A back to back connected SCR/SCR or SCR/Diode modules; there is a facility to accept two thermostat input for fan control and over temperature trip function; it is suitable for wide range of three-phase line voltage 110 to 500 VAC. Stud mounted or DIN rail mounted; and ready to use thyristor switch modules LTSM-XX are also available. The company is engaged in providing solutions for accurate temperature measurement and control of electrical heating systems.



Contact:

Libratherm Instruments Pvt Ltd
401-403, Diamond Industrial Estate, Ketki Pada Road
Dahisar East, Mumbai 400 068
☎ 022 – 4255 5333 • Mob: 98700 11544
E-mail: sales@libratherm.com

Slat Conveyor & Roller Conveyor

Anyway Engineering specializes in offering best-in-class Slat Conveyors and Roller conveyors to their valuable patrons. The slat conveyor (*pix, top*) is used for assembly line and handling of heavy loads. Customers can further avail conveyor according to their requirements. The company manufactures high quality Roller conveyors (*pix, bottom*) that are serving many industries. The company's products range includes: Power Driven Roller Conveyors, Gravity Conveyors, Accumulation Roller Conveyors, and Palletizing Roller Conveyors. High Quality Galvanized Rollers and High Tension Chains add to its quality for heavy loaded Conveyors. The conveyors are highly used in liquid filling Lines and Packaging industries.



Contact:

Anyway Engineering
Factory No: 3, Sonarpada (Mhatre Pada)
Near Tempo Naka, Behind W-230, Phase-II
Dombivli (East), Maharashtra 421 204
Mob: 98214 65799 • E-mail: anywayengg@gmail.com

Techno-Mepper Servo Plastic Injection Moulding Machines

Technovation International offers TM-MD Series Servo Energy Saving Plastic Injection Molding Machine, which carries on its excellent performances and is also equipped



with the high quality servo motor control system, which has not only raised the accuracy of plastic injection, but also saved water and electricity greatly, thus leading a totally new revolution for hydraulic plastic injection machines. Machine Features: High Energy saving – in an ideal working state, compared with conventional injection molding machines, their energy saving can reach 20%-80%; Better Molding stability – Compared with conventional injection molding machines, repeatability is really improved due to servo motor close-loop control; Quick Response – sensitive servo motor, the response time only 0.05 second; Quiet and low noise – the machine runs with low noise and will be much quieter in a low speed; Reliable Holding Pressure – comparing with all electric injection molding machine, the time for pressure holding will be much longer and steady; Oil Temperature Rise Slowly servo motor proportionally deliver hydraulic oil base on needs, it can prevent unnecessary heat being generated, even in some cases it does not require cooling; TM-MD Excellent characteristic inheritance – outstanding machine stability, being safety and dependability, strong mechanical parts, complete functional human-oriented operation system and long service life. The Company is engaged in manufacturing and importing a wide range of Servo Plastic Molding machines, Quick Mould Change System (Hydraulic/Magnetic), Bi-Metal Screw Barrels, Servo Systems, Servo Robots and all types of Auxiliaries.

Contact:

Technovation International
Excel-502, Imperial Estate
Sector-82, Faridabad, Haryana, 121006
Mob: 99101 78880, 98211 29905

De-Magnetiser

Ambica De-Magnetisers are ideal for Tool-Room and most suitable to de-magnetise machine components, drills, gauges, tools, cutters, bearings, dies and punches, etc.

Contact:

Ambica Electronics
108 DSIDC Complex, Okhla Industrial Area
Phase-1, New Delhi 110 020
☎ 011 – 2681 7443, 2681 0332
E-mail: ambica@ambicamagnet.com

Limit Switches

Esbee Electrotech LLP introduces a wide range of Limit Switches in different mounting sizes in metal (aluminium dia casting) and plastic that caters to customers across varied industrial applications and customized requirements.



Salient features: Rigid construction with metal body and plastic cover; Made in engineering plastic with high mechanical strength and heat sustenance capacity; Cable entry from bottom side with provision of cable gland PG 13.5/M20; Oil, water and dust proof; Mechanical life – 10,000,000; Stainless steel plunger and adjustable roller; Available in different actuators to suit different applications; Higher current rating. Applications: Limit switches are used in a variety of applications and environments because of their rigid construction, modest visible operations, ease of installation and operational consistency. Esbee offers a range of limit switches suitable for a wide variety of applications such as Lift doors, Escalators, Conveyor belt systems, Machine automation, Safety locking and unlocking, Plastic moulding, Pharmaceutical processes, Material handling equipment, etc.

Contact:

Esbee Electrotech LLP
S-42/1, MIDC Bhosari, Pune, Maharashtra 411 026
☎ 020 – 4690 7300 • E-mail: info@esbee-electrotech.com

Internal Dial Caliper Gauge

India Tools & Instruments offers Internal Dial Caliper Gauge. Its Product Descriptions are: Internal Caliper Gauge to measure internal diameter of cylindrical workpiece and recessed groove diameter; it can measure groove diameter of “O” ring by modifying spare contact point; set dimension within ± 1 mm (indication range 2mm) can be comparatively measured by alternatively using auxiliary spare contact point in accordance with measured dimension; and range: 20-35mm, 30-62mm, 55-153mm (also available other range from 0.5mm to upto 500mm & above as per requirements). Also available in digital, many make/brand make.

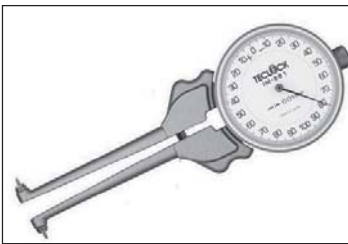

Contact:

India Tools & Instruments Co
Mumbai
☎ 022 – 2342 8862 Mob: 098193 45050
E-mail: ojus_itico@hotmail.com

Lab Furnace

British Electricals offers Lab Furnace BLF-1200, which a compact bottom loading lab furnace for 1200°C ideal for R&D application and ceramic industries like dis integration, Test and analysis of Advance Ceramic Sample, Glass melting, Refractory porosity, Long term temperature test, Firing and sintering, Semiconductor industries for annealing silicon, Silicon carbide and Nitride samples. Furnace have electrically operated elevator for ease of loading/unloading operation furnace uses latest medium wave infrared technology controlled by Micro Processor Based, Fuzzy logic PID control with programmable profile for 2 Pattern of 8 step each for programming rate of Temp rise and hold time (Ramp/Soak), RS-232 Communication port is provided for on-line monitoring/controlling and data logging with software provided, multiple using can be monitored using same software (up to 30 diff furnaces Modbus RS-485 interface in place of RS-232) fully insulated for electrical and heat. Power: 230 V AC $\pm 10\%$ 50 Hz, 2000 W; Size: 485 mm (L) x 325 mm (D) x 690 mm (H); Weight: 26 kg approx.; Option: Inert gas/vacuum atmosphere 1400°C and 1800°C range.



Contact:

British Electricals
237/8 Sonal Link Industrial Estate, Building No: 2
Link Road, Malad (West), Mumbai 400 064
☎ 022 – 2880 8335 • Fax: 022 – 2888 5192
E-mail: sales@britishelectricals.com

Gearboxes

MGM-VARVEL offers a range of Gearboxes – RS-RT Worm gearboxes: 28 to 150 mm centres. One stage worm, helical/worm and double worm; RD Helical gearboxes: 50 to 2300 Nm. Two and three stages; RN parallel shaft gearboxes: 180 to 3300 Nm, Two and three stages; RO-RV bevel/helical gearboxes: 180 to 3300 Nm. Three stages; RG precision planetary gearboxes: 10 to 230 Nm. One and two stages; VR dry friction speed variators: IEC63 to IEC90 1 to 5 stepless speed range, 300 to 1500 rpm; VS planetary speed variators: IEC71 to IEC112, 1 to 5 stepless speed range, 200 to 1000 rpm.



Contact:

MGM-VARVEL Power Transmission Pvt Ltd
Ware House No: G3 & G4, Ground Floor
Indus Valley's Logistic Park, Unit 3, Mel Ayanambakkam
Vellala Street, Chennai 600 095
☎ 044 – 2653 3665 • E-mail: info@mgmvarvelindia.com

**Subscribe to
Industrial Products Source
at ₹750/- for 3-year.**

Bag House Dust Collectors

MASYC, an ISO 9001-2008 certified company specializes in the field of Bulk Material Handling System, Conveyor Equipment, Crushers, Screens and Bag Filters, etc. For sustainable and safer environment, Masyc Bag House Dust Collector is used for various applications in the process plants such as Cement, Coal, Chemicals, Thermal Power plant, Paper and Pulp, Mining and Minerals, Steel, Sugar and Food Industries etc. Masyc bag filter (Dust Collector) works on the principle of Pulse Jet Technology. A powerful shockwave passes through the filter cartridge during cleaning. The dust is discharged from the filter surface and the downwards flowing air allows it to fall in to the container. The pulse from the valve is distributed into the cartridge via a unique laser cut zigzag slot along the length of the blow pipe. The effect of the cleaning is further enhanced by the Venturi shaped outlet of the cartridge. The result of the innovative cleaning and cartridge design gives an overall increased efficiency and lower operating costs. Masyc Dust Collector (Bag Filter) is manufactured under the latest and innovative design aspects and technology. For example, the tube sheets are always laser cut to maintain the utmost accuracy in maintaining the perfect verticality of each bag. Normally the enclosure of the Bag Filter is fabricated in Panel formation so as to avoid excessive welding of stiffeners on the outer wall of enclosures. Each panel is laser cut and then bent on the computerized machine which ensures the perfect assembly prior to final welding. Further the Rotary Air Lock, Screw Conveyor and Chain Conveyor required for conveying the dust from the dust hopper are also manufactured in house.

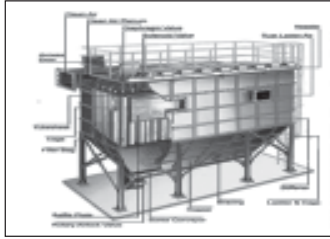

Contact:

Masyc Projects Pvt Ltd
23 Community Centre, Mayapuri, Phase-1, New Delhi 110 064
☎ 011 – 2811 3383, 2811 5745 • Fax: 011 – 2811 6850
E-mail: masyc@masycproject.com

TIG (Tungsten) Electrode INOSTAR

SAP Industries offers TIG (Tungsten) Electrode INOSTAR manufactured by Wolfram Industrie of Germany. Features: Cleaner welding seam with less burn-off; Improved performance with less posser; Better efficiency with less gas; Longer service life due to less deformation; Fewer failures due to highest arc quality. The Company also supplies Weldcut TIG Electrodes, MIG Welding Torches and Spares, etc.



Contact:

SAP Industries
A-541, TTC Industrial Area, MIDC
Mahape, Navi Mumbai 400 710
☎ 022 – 2778 1819 • E-mail: info@sapweldcut.com

Welding & Cutting Equipments

WIM is a well-established manufacturer of welding and cutting equipment. Founded in 1972, Welding Industries Malaysia is a leader and prime manufacturer of welding products with an on-going commitment to produce high quality, user friendly, industry specific, reliable, durable and technologically advanced welding equipment. WIM India is an Indo Malaysian Joint Venture between Welding Industries Malaysia Sdn. Bhd and Centroid Group, India. WIMIPL also provides after-sales support, training to technicians of buyers and train manpower to become qualified welding technocrats. WIM range includes MMA, MIG, TIG, Spot Welding, Plas-



ma Cutting, Plasma Welding and Robotic Automation. About 70 per cent of more than 60 models of Welding Machines, particularly key parts like transformers and PCBs are made by WIM.

Contact:

WIM India Private Limited
380 Dr Nanjappa Road, Coimbatore, Tamil Nadu 641 018
☎ 0422 – 438 0081, 438 0082 • E-mail: info@wimindia.com

Load Cell

Truck Weigh Systems India Pvt Ltd offers Load Cell. Features: Stainless steel construction 17-4 PH (1.4548); Environmental Protection IP 68 with complete hermetic sealing self-restoring design; Digital load cell with built-in micro controller and A/D conversion; Easy communication (RS485) and fast system setup; Improved handling of corner adjustment, system calibration fault finding and load cell replacement; Cable length: 18 m, Accuracy Class according to OIML R60; Safe overload of 200% and Ultimate overload of 300%; 32 Load cells can be addressed simultaneously.



Contact:

Truck Weigh Systems India Pvt Ltd
2/231 Thudiyalur Road, Kottaipalayam
Coimbatore, Tamil Nadu 641 110
Telefax: 0422 – 265 4420 • E-mail: sales@acutuz.com

Servo Motors

Rotolinear Systems offers AC Brushless Servo Motors. Features are: these are available in range of 0.1 – 115 Nm. The standard frame sizes (square) available are 25, 37, 55, 74, 86, 98 and 142, 190, 240. There are mainly 2 models or series (i.e. TGT Series and TGH Series. TGT Series AC synchronous servomotors are characterized by low inertia, small dimensions, high dynamics, high adaptability and reliability; the servo motors have permanent Neodymium magnets in the rotor. The groove bevels in the stator and segment alignments of magnets on the rotor decrease the torque pulsations; and the normal protection is IP 54 (optional IP 65) and the insulation Class F. TGH Series servomotors are smaller servomotors and the speed is also low. TGH servomotors are 20 to 30 per cent shorter in total length compared to TGT of same torque. TGH motors are available with torque range 0.03 - 25 Nm. The company provides right products and solutions to major CNC machine tools builders, SPM builders and machinery builders.



Contact:

Rotolinear Systems
72 Ground Floor, 1st Main Road, LIC Colony
Yeswanthpur, Bengaluru, Karnataka 560 022
☎ 080 – 2357 2855 • Mob: 98451 96751
E-mail: rotolinearindia@vsnl.com

Industrial Pumps

Industrial Pumps & Instrument Co supplies a range of Industrial Pumps such as Chemical Pump, PP Seal Less Magnetic Pump, SS 316 Dairy Pump, Gear Pump With

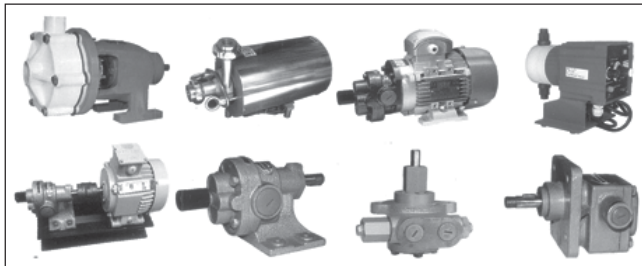

Motor; Dosing Pump, Gear Pumps, Fuel Injection Pump, Crusher Pump, Bitumen Pump, Lubrication Oil Pump, SS 316 Gear Pump, Flange Mounted Gear Pump, Air Operated Diaphragm Pumps, Electrical Barrel Pumps, etc. Also offers Steam Valves, Globe Valves, Ball Valves, Butterfly Valves, Foot Valves, Safety Valves, etc.

Contact:

Industrial Pumps & Instrument Co
9/240 Dr Nanjappa Road, Coimbatore, Tamil Nadu 641 018
☎ 0422 – 435 6118 • Mob: 9842288195
E-mail: piccbe@hotmail.com

Moulds & Dies

Asavari Enterprises, an ISO 9001: 2008 Certified Company is a mould making Company has been specialized in designing and manufacturing plastics pipe fitting moulds for drainage system, water supply, and irrigation systems as

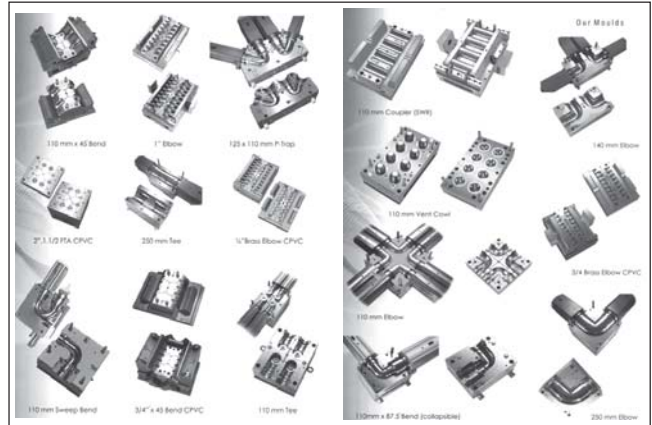

well as other plastics parts moulds. Asavari Enterprises introduced the latest advanced production technology in Collapsible Core Fitting Moulds, and is capable of researching and marking large size and high precision moulds.

Contact:

Asavari Enterprises
Samita Ind Estate, Gala No: 15, Building No: 13
Andheri-Kurla Rd, Sakinaka,
Andheri (E), Mumbai 400 072
☎ 022 – 2850 5654 • Fax: 022 – 2851 4342
E-mail: sales@asavarienterprises.com

Thermocouples

Precision Mass Products Pvt Ltd offers Thermocouples for ranges from -200 to 1820oC. Base Metal elements Type J, K, T, E and N are available in Simplex, Duplex or Multi-Point

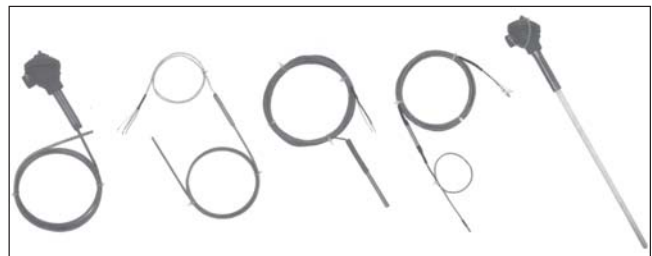

configurations for sheath diameter from 1 to 12.7 mm and materials including SS321, 316, 310, 446, Inconel, Pyrosil, etc. Nobel Metal elements Type R, S and B are available in Simplex, Duplex or Multi-Point configurations with element diameters from 0.3 to 0.5 mm with Single, Double or Triple layer protection of Ceramic 710, 610, Inconel, etc.

Contact:

Precision Mass Products Pvt Ltd
Plot No: 2306, GIDC Chhatral, Tal: Kalol
Dist: Gandhinagar, Chhatral, Gujarat 382 729
☎ 02764 – 233 681, 233 682
E-mail: sales@precisionmass.com

ABB's HVAC Drives Technology Ensures Sustainable and Safe Ventilation of Chennai Metro

Enabling smooth travel and safety of commuters, ABB has provided active front end Variable Speed Drives (VSDs) for the ventilation system of Chennai metro line, a key infrastructure project that connects major areas in the city.

The Chennai Metro takes the planned urbanization agenda a step forward with the opening of the 9-km long extension. The new line will allow passengers to travel



from the northern part of the city to Chennai International Airport in the south in around one hour, and will play a key role in easing the road traffic and enhancing public transportation.

ABB solutions are part of this fourth largest metro system in India with the supply of ACH580 and ACS880 active front end drives to support the metro line's ventilation system and platform cooling. These drives are a part of ABB's HVAC offering designed to meet the highest level of safety, reliability and energy efficiency requirements.

"This is yet another significant milestone for ABB in contributing to India's booming infrastructure and we are proud to be associated with yet another metro rail project in India," said Sanjeev Arora, President, Motion Business, ABB India Ltd. "Spotlight on 'Make in India' initiative is back in the wake of a pandemic that disrupted supply chains. With reforms being charted out for various sectors for improving ease of doing business, we are aligned towards making India a strong and self-reliant nation. Leveraging our strong local manufacturing footprint, we are able to provide customized solutions for these key infrastructures Projects," he added.

HVAC drives features for increased safety and reliability

Rail and road tunnels mandate rigorous ventilation standards for air quality and fire safety features. ABB drives are used together with electric motors for the effective control of tunnel ventilation fans. They are integral in the operation of advanced air exchange systems in the stations and tunnels, ensuring passengers, comfort and saving energy in normal operation as well as contributing in safe evacuation, smoke extract and fire fighting in case of emergency.

The dedicated voltage boost feature of ABB's HVAC drives addresses voltage-drop issues caused by long cables in the tunnel network. With this feature, fans are always able to provide a nominal air flow without a need for any external equipment to compensate voltage drop. This brings enormous cost benefits to the project.

Almost non-existent harmonics, thanks to the drives' active front end design, mitigate the risk of the network overload, ensuring continuous ventilation and efficient power supply.

The 'fireman's override' feature allows VSDs on smoke extraction and pressurization fans to maintain safe escape routes for the passengers, ignoring non-critical faults and warnings e.g. due to too high temperature. In the event of a fire, this mode is usually triggered with a special key at the fireman's control station.

Strong partnership for critical infrastructures

ABB India has partnered with Sterling Wilson, one of the leading EPC companies, to provide HVAC solutions for the Chennai metro project. ABB has long standing association with Sterling and has partnered on several critical infrastructure projects in India, the major one being Asia's longest road tunnel in Jammu and Kashmir. The 10.8 kilometre Chenani-Nashri tunnel in Jammu & Kashmir is the longest highway tunnel in Asia, featuring a state-of-the-art ABB ventilation control system.

ABB has played a key role in transforming the intra-city metro transportation system in the country by providing an extensive array of products and systems for wayside power and onboard requirement. About 50% of the Indian metro lines run on ABB technologies like medium voltage Uni-gear, LV ArTuK and gas insulated switchgears. Current operational metro lines in Kochi and Bengaluru use the support of ABB solutions to transport millions of passengers safely every day.

LANXESS Signs Contract to Acquire Emerald Kalama Chemical

- Acquisition with sales of USD 425 million and EBITDA of USD 90 million to strengthen Consumer Protection segment
- Enterprise value of USD 1.075 billion
- High-margin new application fields in food industry and animal health
- Rapid integration expected

Specialty Chemicals Company LANXESS is accelerating its growth course and signed a binding agreement to acquire 100 per cent shares in Emerald Kalama Chemical on February 14, 2021. The US-based company is a globally leading manufacturer of specialty chemicals, especially for the consumer segment, and is majority-owned by affiliates of the US private equity firm American Securities LLC.

The enterprise value of Emerald Kalama Chemical amounts to USD 1.075 billion. After deducting debt-like items, the purchase price is around USD 1.04 billion (EUR 867 million*), which LANXESS will finance from existing liquidity. The transaction is expected to be completed in the second half of 2021. It is still subject to approval by the relevant authorities.

In 2020, Emerald Kalama Chemical achieved sales of around USD 425 million and EBITDA pre-exceptional of approximately USD 90 million. Within three years following the completion of the transaction, LANXESS expects an additional annual EBITDA contribution of around USD 30 million (EUR 25 million*) from synergy effects. The acquisition will already be earnings per share accretive in the first fiscal year after its completion.

“We are gaining further momentum on our growth course. The businesses of Emerald Kalama Chemical are an ideal fit for us. We will further strengthen our Consumer Protection segment and open up new application areas with strong margins, for example in the food industry and animal health sector. In addition, we will also enlarge our presence in our growth region of North America. All this will make us even more profitable and stable,” said Matthias Zachert, Chairman of the Board of Management of LANXESS AG.

Emerald Kalama Chemical employs approximately 500 employees worldwide and runs production sites in Kalama, Washington (USA), Rotterdam (Netherlands) and Widnes (Great Britain). Emerald Kalama Chemical gener-

**Based on exchange rate of EUR/USD = 1.20.*



ates around 45 per cent of its turnover in North America. “Emerald Kalama Chemical has a very efficient setup, bundling all its production activities at only three sites. That is why we expect to integrate the new business very quickly,” said Zachert.

Targeted portfolio expansion in the Consumer Protection segment

Emerald Kalama Chemical generates about 75 per cent of its turnover with specialties in the consumer segment. These include preservatives for food, household and cosmetic applications, flavors and fragrances as well as products for animal nutrition. The remaining 25 per cent of sales come from the specialty chemicals business for industrial applications, including the plastics and adhesives industries.

With the acquisition, LANXESS is pursuing a targeted expansion of its portfolio: The company has a strong position in the global business with antimicrobial active ingredients and preservatives, including for consumer protection products and animal hygiene. Examples are disinfectants effective against the Coronavirus or the African Swine Fever.

About LANXESS:

LANXESS is a leading specialty chemicals company with sales of EUR 6.8 billion in 2019. The company currently has about 14,400 employees in 33 countries. The core business of LANXESS is the development, manufacturing and marketing of chemical intermediates, additives, specialty chemicals and plastics. LANXESS is listed in the leading sustainability indices Dow Jones Sustainability Index (DJSI World and Europe) and FTSE4Good.

REC Signs MoU for Financing 600 MW Hydro Electric Project in Bhutan

REC Limited, Navratna company under the Ministry of Power, along with Power Finance Corporation Limited has signed Memorandum of Understanding (MoU) on 9th March 2021 with Kholongchhu Hydro Energy Ltd. (KHEL) for financing of 600 MW Hydro Electric Project at TrashiYangtse, Bhutan. KHEL is a JV company of SJVN (India) and Druk Green Power corporation Limited (Bhutan) set up with 50:50 shareholding pattern for the development of 600 MW Kholongchhu Hydro Electric Project in Eastern Bhutan. The MoU was signed in the presence of Sh. Sanjay Malhotra, CMD - REC, Sh. RS Dhillon CMD - PFC, Sh. NL Sharma, CMD - SJVN and Sh. Yeshi Wangdi Chairman KHEL. From REC Limited, Sh. SK Gupta, Director (Technical), Sh. Ajoy Choudhury, Director (Finance) and Sh. TSC Bosh, Executive Director were also present along with other senior officers who joined virtually.

The project is being executed as per an inter-governmental (IG) agreement signed between the Govt. of India and the Royal Govt. of Bhutan (RGoB) in April 2014 to undertake implementation of four hydroelectric projects in Bhutan through a Joint Venture (JV) model to be formed by PSUs of the two governments. Kholongchhu Hydro Energy Limited (KHEL) is, the first Joint Venture Company being undertaken between the two governments for implementation of 4x150 MW Kholongchhu Hydro Electric Project. KHEL has signed a Concession Agreement with The Royal Govt. of Bhutan dated 29.06.2020 for a concession period of 30 years. The project is proposed



to be funded in debt-equity ratio of 70:30 and as per the MoU, REC would be extending Rupee Term Loan of Rs. 2029 Crore. The balance debt shall be extended by PFC (Rs. 2029 Crore), NPPF, Bhutan (Rs. 200 Crore) and Bank of Bhutan (Rs. 200 Crore).

About REC Limited: REC Limited is a Navratna NBFC focusing on Power Sector Financing and Development across India. Established in 1969, REC Limited has completed over fifty years in the area of its operations. It provides financial assistance to state electricity boards, state governments, central/state power utilities, independent power producers, rural electric cooperatives and private sector utilities. Its business activities involve financing projects in the complete power sector value chain; different type of projects includes Generation, Transmission, Distribution Projects, and Renewable Energy projects.

Contact:

REC Limited

E-mail: reccprco@gmail.com; contactus@recl.in

ABB Softstarters Help Shimla to Get Access to Uninterrupted Water Supply

Shimla has cut pipeline damage 50% using ABB Softstarters to help lift water thousands of feet from a dam to quench the thirst of millions.

The town of Shimla in the Indian Himalayas is one of the country's busiest tourist destinations. It receives 3.6 million visitors a year, significantly augmenting the local population of 3 million. Known as the Queen of Hills, Shimla has experienced an acute water crisis as its popularity increased.

The Himachal Pradesh Jal Shakti Vibhag (formerly known as IPHD) has thus developed a plan to modernize the existing lift water supply plan with construction and

upgrading of old pumps to raise water from the Kol Dam on the Satluj River thousands of feet below the city. The aim was to bring safe, clean drinking water to the population with minimal water loss and minimal environmental damage.

“With smart technology and our state-of-the-art products and solutions, ABB electrification products are helping residents of Shimla to get an uninterrupted supply of water,” said C. P. Vyas, president of the electrification business for ABB India. “ABB’s Softstarter device ensures smooth water movement while torque control minimizes leakage and pipe damage, eliminating pressure

surges. With leakages being an important area of concern for the water industry, we are proud to set a benchmark for electrification technologies that help solve critical challenges,” he added.

ABB Softstarters wash away issues caused by conventional starters

While demand has grown every year, the aged water infrastructure has been losing 20-25% of the total water supply to leakage. Aggravating the problem, no major body of water is available in the vicinity of the main city, and the area’s steeply sloping landscape allows rainwater to run off quickly.

For some pumping stations, the IPHD was having problems of water hammering when stopping pumps and frequent blown fuses caused by current spike. To avoid such issues, IPHD decided to install eight ABB PSTX Softstarters for the Shimla project. IPHD had a sizeable installation of ABB Softstarters in other water supply systems and had been satisfied with their performance, easy handling and ease of use.

Softstarters shrink service calls and pipeline damage

The IPHD now estimates that, with reduced mechanical wear and 30 per cent fewer service calls, PSTX Softstarters can cut pipeline damage by up to 50 percent during starting and stopping operations, leading to overall cost savings.

The Shimla installation project had a very ambitious completion deadline, but ABB was able to meet the customer’s expectations, supplying the Softstarters on time. As a result of the customer’s confidence, S B Trading is now commissioning several orders with ABB to ensure safe, smart and sustainable water in the region.

ABB (ABBN: SIX Swiss Ex) is a leading global technology company that energizes the transformation of society and industry to achieve a more productive, sustainable future. By connecting software to its electrification, robotics, automation and motion portfolio, ABB pushes the boundaries of technology to drive performance to new levels. With a history of excellence stretching back more than 130 years, ABB’s success is driven by about 105,000 talented employees in over 100 countries.

ABB’s Electrification Business Area is a global leader in electrical products and solutions, operating in more than 100 countries, with over 200 manufacturing sites. Our 55,000+ employees are dedicated to delivering safe, smart and sustainable electrification. With ABB Ability™ enabled digital solutions at its core, our portfolio protects, connects and optimizes the flow of electrical energy, including the integration of renewables and energy storage for smarter electricity distribution for utilities, industry, infrastructure and transportation. For more information visit: <https://go.abb/electrification>



TwinCAT Software now Supports S7 Communication Protocol

PC-based Control Simplifies Integration of S7 Controllers

The openness of PC-based control and the resulting array of connectivity options with other systems number among the fundamental advantages of TwinCAT automation software from Beckhoff. A new add-on now also enables easy and efficient communication with Siemens S7 controllers.



TwinCAT 3 software now offers efficient connectivity with S7 controllers.

TwinCAT 3 offers numerous options for connecting TCP/IP-based thirdparty systems to the main control program: OPC UA, MQTT, HTTPS and Modbus are only a few prominent examples of an entire range of communication protocols. The TwinCAT S7 Communication (TF6620)

function now expands this broad spectrum to include the S7 communication protocol.

This product implementation enables reading and writing of variables from an S7 controller. The PLC application program carries this out directly – either via dynamically parameterizable PLC function blocks or via easily configurable I/O mapping. No additional hardware is required and the local TCP/IP network serves as the transport medium.

Contact:

Beckhoff Automation Pvt Ltd
9th Floor, Suyog Platinum Tower, Naylor Road
Off Mangaldas Road, Pune, Maharashtra 411 001
☎ 020 - 6706 4800 • E-mail: info@beckhoff.co.in
Web: www.beckhoff.com

FARO® Introduces BuildIT 2021 Software Suite

Simplifies Workflows and Enhances Ease for Manufacturing, Assembly & Construction

FARO Technologies, Inc. (Nasdaq: FARO), a global leader for 3D measurement, imaging and realization solutions, recently announced the release of its most advanced BuildIT 2021 software suite, which represents the next evolution of this platform that simplifies workflows, improves performance and enhances ease of use.

BuildIT offers three individual products – BuildIT Metrology, BuildIT Projector and BuildIT Construction – each designed to address the most challenging quality inspection, manufacturing and assembly or construction issues, offering the most flexible and intuitive user interfaces in their respective applications. While the BuildIT 2021 suite is integrated with FARO hardware products to ensure a best-in-class FARO solution experience, it also delivers high-quality outcomes for non-FARO hardware products.

“The performance enhancements in BuildIT 2021 Software Suite are substantial,” said Vito Marone, FARO Senior Director of Software Product Marketing. “For example, by using this significant upgrade of our BuildIT Construction software, users can complete reports in five minutes or less – a process which used to take 10 minutes or more.”

BuildIT Metrology 2021 features upgrades related to four key areas, including: user experience, probing, scanning and automation:

- **Inspection annotations** – Can now be defined prior to perform any measurement and then computed and populated dynamically as new measurements are added; dynamic annotations are supported for points, lines and curves, and surfaces
- **FARO Laser Tracker Improvements** – Integrates the latest SDK (software development kit) to provide a more seamless Wi-Fi experience by handling disconnections and reconnections automatically
- **Improved GD&T** (geometric distancing & tolerancing) – Runout and total runout tolerances are now supported with any DRF file extension that frees DoF (degrees of freedom) required for a proper evaluation of tolerances
- **Faster alignment and analyses** – By trading a few microns in accuracy, the alignments and analyses gets a boost in speed between 10X to 100X
- **Auto-complete and syntax highlighting** – Are now available in the process editor to streamline writing automated processes; tooltips can also be displayed for provid-

ing documentation on the go

BuildIT Projector 2021 comes complete with an enhanced user interface and includes instant projection – a feature optimized for low production environments and one-off workflows. With no planning needed, it is the fastest way to go from importing the CAD model to projection. BuildIT Projector 2021 also features the ability to:

- **Pick Alignment Points on the Fly** – The TracerSI lets you align directly to features on the part. For those workflows, all users have to do is pick an alignment point, coordinate from the CAD, aim the scanbox at it, scan, and accept if the contrast is good enough
- **Operator Gamepad Remote & Mobile Remote** – One gamepad remote can control multiple projectors, allowing the operator to spend more time assembling and less time walking back and forth from the computer station. Mobile remote has several new features and contains all the controls needed to run an alignment routine
- **Unparalleled Automation** – These capabilities can now be leveraged as part of a projection plan, as layers have a Layer Process property, which specifies which process should be automatically launched when the operator reaches this layer

BuildIT Construction 2021 boasts a guided user interface for concrete floor flatness analysis and an object-based analysis to simplify reporting to all stakeholders, allowing for a quick and easy comparison of what was built versus the original design. Now, users can enhance their learning curve, uncover inconsistencies, and deliver complete reports on day one using the new guided workflow. With object-based analysis, users can also verify a complete building level against the original file and uncover within minutes which elements onsite were placed beyond tolerances – all while sharing this vital information with project stakeholders in real time. Other unique value-add benefits include:

- **Comprehensive Tank Analysis Package** – Determines and identifies critical issues in the plant facility that support faster modification and renovation
- **Significant Reduction in Onsite Cycle Time** – From laser scan projection data preparation to 3D visualization
- **Streamlines Raw Scan Import Process** – Feature automatically detects targets and facilitates faster alignment

with the software

- **Numerous Workflow Efficiency Improvements** – Includes file size reduction, faster rendering and clipping box functionality

About FARO

For 40 years, FARO has provided industry-leading

technology solutions that enable customers to measure their world, and then use that data to make smarter decisions faster. FARO continues to be a pioneer in bridging the digital and physical worlds through data-driven reliable accuracy, precision, and immediacy.

For more information, visit: www.faro.com

SKF India Unveils 3 New Automotive Aftermarket Products

- New products enable SKF to meet customers' evolving needs of performance and value
- Boasts of high quality and performance parameters in line with SKF quality standards

To address customer needs for improved durability and performance, SKF India's Automotive Aftermarket division recently announced the launch of three new products. Created to address the changing demands of customers across sectors in India, the new products including Chain and Sprockets for 2-Wheeler, Timing Belts and Steering and suspension systems for 4-wheelers. This range of new innovative products are of high quality, superior strength and deliver long life.



Chains and sprockets

Commenting on the new offerings, S Venkat Subramaniam, Director Automotive Business SKF India Ltd. said, "These new Automotive aftermarket products demonstrates our dedication to understanding and fulfilling the needs of our customers. Designed to support the enhanced performance needs, these new products come with world class quality, which SKF is known for and aims



Timing Belts

to deliver great reliability and durability to vehicle owners of both two and four wheeler category. We believe that customer satisfaction is paramount and have been working on introducing new product lines that deliver the correct balance of performance and value to customers."



Steering and suspension

Features and benefits - Chain and Sprockets for 2 Wheeler: High quality; Low noise level; Superior strength.

Timing Belts for 4 Wheelers: High strength and tensile cord; Resistant to heat and oil; High load-carrying capacity.

Steering and suspension for 4 wheelers: Superior load carrying capability; High durability; and long life.

Building on our strong product experience and technical expertise, SKF is committed to innovate, apply fresh thinking, create new business models and use our skills, experience and resources to help customers meet their needs, today and in the future.

About SKF:

SKF's mission is to be the undisputed leader in the bearing business. SKF offers solutions around the rotating shaft, including bearings, seals, lubrication, condition monitoring, and maintenance services.

SKF is represented in more than 130 countries and has around 17,000 distributor locations worldwide.

Visit: www.skf.com

Visit: www.ips.co.in
to view our e-magazine

Products INDEX

A		By-Pass Rotameter	23
Aerosol Generator	25	C	
After Coolers	27	Cabinet Cooler	10
Air Cooler	27	Capacitance Type Level Transmitters	23
Air Gauges	c-ii	Carry Case Coal Gas Analysers	17
Air Sterilizer	41	Carry Case Emission Analysers	17
Air Velocity Kit	23	Cartonator Pockets	4
Alloy Steels	5	Ceramic Thread Guide	16
Ambient Air Quality Monitors	17	Chillers	27
Analog Timer	15	Chip Trapper	10
Anti-Collision Device	6	Clamps for Photo Cells	4
Armchair	6	CNC Engraving & Milling Machine, Model Velocity VX-4535	27
Auto Tune PID Controllers EC Series	42	CNC External Cylindrical Grinding Machine	36
Automated Quality Inspection	c-i	CNC Internal Cylindrical Grinding Machine, Model ICG-100	30
Automated Reference Method Sampler	3	CNC Polygon Turning Machine	32
Automated Welding	26	CNC Router Machine	6
Automatic Cutting Machine for Corrugated Tubes	41	CNC Wire Abrasive Cut Machine, FQT Series	29
Axis Drop Preventer in CNC Machines	9	Coiled & Disc Springs	5
B		Cold Cun	10
Back Pressure Regulator	18	Cold Work Tool Steels	5
Bag Filter	26	Combustion Efficiency Monitors	17
Bag House Dust Collectors	46	Conductivity Level Switches	23
Ball Screw Driver Actuator Type	c-i	Cone Crusher	3
Ball Screws	29	Connectors	c-iv
Ball Valve, 3-Way Floating	14	Conveyor Belts	25
Barometer	23	Conveyors & Components	4
Bearing Puller Interchangeable Tip	26	Cooling Tower Water Treatment Systems	38
Belt Conveyors	3	Counters	21
Bimetallic Barrels	32	Crane Automization	6
Bipod	4	Crane Scale	6
Blow Moulding Machines	27 & 40	Crimping Press	37 & 43
Brackets & Guides	4	Custom Build Gear Boxes	7
Brass Fittings	14	Cylindrical/Taper & Grooved Pins	42
Brute Force Screen	3	D	
Built-in Cylinder Power Collet Chucks	8	De-Magnetiser	44
Butterfly Valve 2-Way with Pneumatic Double Acting/Spring Return Actuator	14	Die Steels	5
Buttweld Fittings	36	Differential Pressure Transmitters	13
Buttweld/Socket Weld/Screwed Fittings	29		

Digital Indicators	13	Gearboxes	45
Digital Preset Timer	15	Geared Motors	7 & 19
Digital Pressure Gauges	13 & 23	Geared Shafts	c-iii
Digital Pressure Switches	23	Gears, Gear Components & Gear Assemblies	11
DIN Connectors	c-iv	Glandless Transformer Oil Pumps	20
Double Block & Bleed Valve (DBB)	23	Glass Tube/Acrylic Rotameters	23
Double Column Bandsaw Machine		Gravity Limit Switch	6
Model LMG 200 H (Semi-Automatic)	30	Green Chemical Distillation Plant	22
Drill Bushings & Machined Components	24	Ground Gears c-iii	
Dust Monitor	17	Guided Wave Radar Level Transmitters	
Dynamic Balancing Machines, Vertical Type	35	(Rod/Cable Type)	39
E		H	
EDM Drilling Machine	34	Hair Pin Heat Exchanger	27
Electric Tube Cleaner	35	Handheld Laser Welding Machine	19
Electrical Insulation Tape – FR	10	Hard Jaws	c-ii
Electro Hydraulic Thrustor	6	Heat Exchangers	27
Electro Hydraulic Thrustor Brake	6	Heavy Duty Bag Closing Machine	36
Electromagnetic Flowmeters	13 & 23	Heavy Duty Bucket Elevator	3
Electronic Safety Guards	21	Helical Gear Boxes	7
Endless Belts	25	Helical Gear	c-iii
Energy Efficient Air-Compressor	42	High Frequency Screen	3
Engineering Polymer Components	c-iv	High Performance Multi Spring Seal	12
Engineering Unit	18	High Precision Case Hardened and	
F		Profile Ground Gears	7
Fastener Handling Slat Conveyors	42	High Precision Gears	c-iii
Finned Tubes	27	High Quality Precision Moulds	
Flash Dryers	12	and Components	24
Flat Super Air Nozzle	10	Hollow Shaft Helical Gear Boxes	7
Flexible Couplings	29	Hot Extractive Cems Analysers	17
Flexible Geared Coupling	6	Hot Runner Temperature Controllers	13
Flow Switches	23	Hot Stamping Machine for Round Objects	32
Food Repeping Analysers	17	Hot Work Tool Steels	5
Forging Components	5	Hour Meter	15
FRP/GRP Poles	10	Hydraulic Press, 4-Column Type	38
Fuel Additives	13	Hydraulic Presses & Machinery	34
G		I	
Gas Analysers	17	Impact Hammer Crusher	3
Gas/Heavy Oil Burners	4	Impact Sockets	5
Gas/Light Oil Burners	4	Incremental Encoders	18
Gauges	c-ii	Industrial Burners	4
Gear Boxes	19	Industrial Dual Block Burners	4
Gear Motors & Gearboxes	43	Industrial Pumps	47

Industrial Rotary Vacuum Dryer	22	Modular Supports	4
Insulated Conductor Bar	6	Mould Base, Precision Components	38
Intercoolers	27	Moulds & Dies	47
Internal Dial Caliper Gauge	45	Multi Axis (4 Axis) Auto Laser Welding Machine,	
Inverter Cabinets, 3 CFL	21	Galaxy WD Series	21
Ion Air Cannon	10	Multi Crowned Gear Couplings	7
Iron Worker	27	Multi Wire Cable Trolley	6
J		Multichannel Gas Detection Systems	17
Juice Dispensing Machine	13	N	
K		Magnetic Grills	20
Knife Gate Valve	19	Nylon Sandwich Belts	25
L		O	
Lab Furnace	45	Oil Cooler	27
Laser Marking Service	24	Oil/Gas/Dual Fuel Burners	4
Lever Limit Switch	6	Online Gas Analysers	17
Lift Duty Gear Boxes	19	Oxygen Analysers	17
Limit Switches	17 & 45	P	
Line Vac	10	Packaging Machines	24
Liquid Column Manometers	23	Packing Machines	28
Liquid Level Controller	15	Paper Straw Making Machine	30
Liquid Level Indicators	23	Perlon Ropes	25
Liquid Level Switches (Float Operated)	23	Pet Strength Blow Moulding	
Liquid Level Transmitter	23	Machine, Polo Series	40
Liquid Ring Vacuum Pumps	16	Phase Failure Relay	15
Load Cells	13 & 46	PID Temperature Controller	15
M		Pin Type Load Cell	6
Magnetic Coolant Filters	34	Pipe Conveyors	3
Marconite Earthing System	20	Plain Plug Gauges – Tieco Brand “Measuring	
Master Controller	6	Technology on the Right Track”	25
Material Handling Equipment	6 & 12	Plain Ring Gauges	c-ii
Measuring Instruments	23	Planetary Gearbox PE/PBE Series	15
Measuring Gauges	c-ii	Plastic Injection Molding Components	
Measuring Pins	c-ii	and Products	23
MEBA – Bimetal S	32	Plastic Injection Moulding Machine	41
Melt Pressure Transducer	13	Plastic Modular Belting	15
Metal and Non-Metal Laser Cutting Machine	6	Plastic Mould Steels	5
Metal Tube Rotameter with Transmitter /		Plastic Moulds & Dies	38
Flow Indicator Totalizer	23	Pneumatic Boiler Tube Cleaner	16 & 19
Metal Working Fluids	14	Poly Flex Belts	25
Micro Drill EDM, BH-703	34	Poly V Belts	25
Mini Chip Vac	10	Polymer Sprockets & Gears	35
Mobile Flow Meter Calibration Skid	12	Portable Gas Analysers	17

Portable Stack Gas Analysers	17	Single Screw and Twin Screw Extruder Gear Boxes	7
Potentiometers	8	Single Toggle Jaw Crusher	3
Power Cables	33	Single Turn Wire Wound Potentiometers	8
Power Chucks	c-ii	Skived Gears	c-iii
Pre Cut Gaskets	22	Slat Conveyor & Roller Conveyor	44
Pre Filters	37	Slewing Bearings	17
Preci Chucks	c-ii	Slim Sockets	c-iv
Precision Injection Moulded Plastic Components	41	SMARTTECH 3D Scanners	c-i & 8
Precision Locknuts	29	Snap Action Switches	11
Precision Moulds	35	Socket with Plug	c-iv
Pressure / Reaction Vessels	27	Soft Jaws	c-ii
Pressure Switches	23	Solar Pump Controller	c-i
Pressure Transmitter	13	Special Gauges	c-ii
Process Instruments	23	Special Gear Boxes	19
Programmable Counter	21	Special Vee Belt & Flat Belt Pulley	25
Proximity Control Unit	15	Spring Steels	5
Pull Back Clamps, TGP Series	24	Spur Gear	c-iii
Pulley in all Pitch for Timing Belt	25	Spur Gears	33
Pulp & Paper Stock Pumps	26	Square & Round Bars	5
Pulse Jet Bag Filter	3	Square Potentiometers	8
R		SS Pipes & Tubes	13
Radiator	27	Standard Socket	c-iv
Radio Remote Control	6	Starter Motor Shafts	c-iii
Removable Tube Bundle	27	Steel Pipes & Tubes	30
Repairs and Servicing of Ball Screws	29	Strain Gauges	13
Resistance Box	6	Super Air Knives	10
Resonance Screen	3	T	
Reverse Engineering	c-i	Taper Gauges	
Rolled Ball Screws	29	Techno-Mepper Servo Plastic Injection	
Rotary Gear Pump, FTMB	15	Moulding Machines	44
Rotary Gear Pump, Type HGSX	21	Tee & Elbow Bevelling Machine	37
Rotary Limit Switch	6	Temperature Controller Indicator	15
Rotary Surface Grinder with Vertical Spindle	36	Temperature Measuring Instruments &	
Rotary Triple Twin Gear Pump	39	Allied Products	23
S		Thermocouples	47
Safeload Controller	6	Thread Gauges	c-ii
Safety Air Gun	10	Through Beam Sensors	21
Safety Guards	21	Thyristor Switch Card for Capacitor Bank	44
Sensors	21	TIG (Tungsten) Electrode INOSTAR	46
Servo Motors	47	Time Switch	15
Shell & Tube Heat Exchanger	27	Timing Belts	25
Short Stroke Cylinders	16	Tool & Alloy-Special Steels	5

Tools – Collets	5	W	
Tripod	4	Water Softener Plant	22
Tube Notching Machine	43	Water Storage Tanks	37
Turbine Blades & TG Components	28	Wedge Space Saver Belts	25
U		Welding & Cutting Equipments	46
U Tube Bundle	27	Welding Machine, MOSFET Base	23
V		Wire Rod	5
Vacuum Manometer	23	Wire Rope Load Cell	6
Vacuum Pumps	16	Wire Wound Servo Potentiometers	8
Valves, Pipes Fittings & Piping System	14	Worm and Worm Wheel	7
Vertical Pressure Leaf Filter	28	Worm Gear Boxes	19
Vertical Shaft Impactor	3	Worm Gears	c-iii
Vertical Turret Milling Machine	25	Y	
Vibrating Feeder	3	Y Strainers Fabricated	28
Vibrating Grizzly Feeder	3	YHB Mist Cleaner	18

A D V E R T I S E R S ' I N D E X

A		Masyc Projects Pvt Ltd	3
ACE Gas Analysers Pvt Ltd	17	Moldex Corporation	4
ACI Engineers	10	N	
Amcats Pvt Ltd	c-i	Nirmal Energy Limited	4
C		P	
Craftsman Automation Limited	7	Pankaj Potentiometers Pvt Ltd	8
Crane Control Equipments	6	Paragon Auto Control	15
F		Photon Controls (India) Pvt Ltd	21
Fitzer Instruments Company (India)	23	Powermag Control Systems Pvt Ltd	c-i
H		Pragati Transmission Pvt Ltd	c-iii
Haris Sensor Technologies Pvt Ltd	13	R	
Heat Cool Fin Industries	27	RK CNC Solutions	9
J		S	
Jayesh Enterprises	c-ii	Shacon Engineering Company	19
K		T	
Kadkraft Systems Pvt Ltd	c-i	The Jaws Mfg. Co.	c-ii
Kwedos Belt Drive	25	V	
M		V.V. Mujumdar & Associates	29
M.Con Connectors	c-iv	Ventura Alloy and Steel Pvt Ltd	5



PRAGATI GEARS



Driven by passion



Hydraulic Pumps



Starter Motor Shafts



Transmission Gears



Industrial Gear Boxes



Power Tools



Defence & Aerospace



Machine Tools



Worm & Worm Wheel



Spiral Bevel Gears



Sprockets

TYPES OF GEARS	RANGE					ACCURACY CLASS
	MODULE		DIAMETER(mm)			
	MINIMUM	MAXIMUM	MINIMUM	MAXIMUM		
SPUR	0.3	8	10	400	DIN 4	
HELICAL	0.3	8	10	400	DIN 4	
SPIRAL BEVEL	0.5	6.5	20	300	DIN 5	
WORM SHAFT	0.5	4	15	100	DIN 6	
WORM WHEEL	0.5	8	30	400	DIN 8	



Ratchets

Pragati Transmission Private Limited,

Shed # A103/A104, 3rd Main Road, 2nd Stage, Peenya Industrial Area, Bangalore- 560 058

Email: kadam@pragatigears.com, mktg@pragatigears.com, pragatigears@rediffmail.com

Tel-91 80 28365364 / 28365352, Mob. 91 9341215974 / 7026618881

www.pragatigears.com



Stay Connected & Energized Through M.CON for Safe & Sure



One Roof Solution for your Solenoid Coil, DIN Connector and Engineering Polymer Components.

AN ISO 9001-2008 CERTIFIED COMPANY

Unit No.134, 1st Floor, C - Building, Anso Industrial Estate,
Saki-vihar Road, Sakinaka, Andheri (E), Mumbai - 72, India.
Tel.: (91) 022 - 2847 2222 | Fax: (91) 022 - 2847 1155
Mob.: +91 99303 94422, 97695 81553, 70216 86267
Email: sales@mcon.co.in, shaji@mcon.co.in, m.con@rediffmail.com
info@mcon.co.in
www.mcon.co.in